

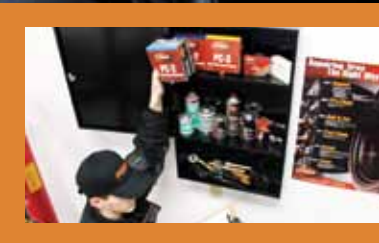

PRODUCT



Tire And Wheel Service Solutions.

Prema Canada is one of the largest distributors of tire and wheel service supplies in Canada, and is a market leader in delivering a total supply solution to the tire industry in Canada. Founded in 1954 as Loomis Root Canada Ltd, the company has evolved from a small, regional automotive and retread supply distributor into a focused network of independent tire and wheel service supply Distributors servicing the entire nation from coast to coast.

PREMA

AME
INTL.



Proudly Supporting Prema Canada



A MESSAGE FROM THE PRESIDENT

Thank you for your interest in Prema Canada's vast array of tire and wheel service supplies and equipment. I sincerely hope that you capitalize on the opportunity to do business with the Authorized Prema Distributor who services your area. Each Prema Canada Distributor is committed to our organizational goal of delivering quality product, backed by industry standard training and expertise, while offering exceptional customer service and delivery. Rest assured that you can rely on your Prema Canada Distributor to look after all of your tire supply needs so that you can focus your time on revenue and profit generating activities.

From tire repair materials, TPMS supplies, balancing weights, lubricants and valve hardware to impact wrenches, studding supplies, jacks, bead breakers and other shop equipment, you can find everything you need at Prema for your tire and wheel service supply needs. Your Distributor can work with you to establish inventory levels that suit your business needs and then manage replenishing those levels on every visit. Our goal is to provide you with what you need, when you need it, and not to overload your shelves with inventory. Your Distributor will visit regularly so that your inventory can be replenished from their fully stocked van at the time of their visit. You will immediately know what you have received and which products, if any, need to be special - ordered for you.

Behind your Prema Distributor is a dedicated team at Prema Canada's new head office and central warehouse in Burlington, Ontario, providing training, product support and inventory expediting services. Together with a network of key vendor partners as well as sister companies across the globe, we bring products, technologies and solutions from all corners of the world right to your place of business.

I am proud to share with you that 2014 is our 60th year in business. Thank you to our long - term customers, our newest customers and our future customers for your business and for your support. We look forward to servicing your needs for many more years to come.

Please feel free to visit our website at www.premacanada.ca to learn more about us. You can browse our product catalogue, find your local Distributor's contact information and learn about the latest news and events in our industry.

Sincerely,

David Lottridge, President, Prema Canada

C E L E B R A T I N G



Sixty Years



ANNIVERSARY

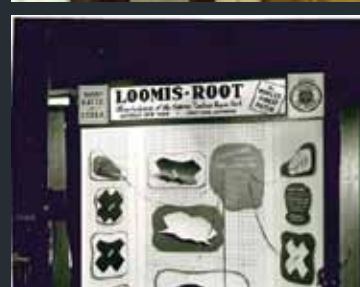

C O N G R A T U L A T I O N S



WHERE LEARNING NEVER STOPS



TRAINING



EDUCATION



RESEARCH AND DEVELOPMENT

**Wherever you are
SALES REPRESENTATIVES**

BRITISH COLUMBIA 10

- NORTHERN 4
- VANCOUVER ISLAND 2
- LOWER MAINLAND 2
- INTERIOR 2

ONTARIO 20

- NORTH WESTERN 1
- NORTH EASTERN 1
- WESTERN 5
- CENTRAL 9
- EASTERN 4

ALBERTA 9

- NORTHERN 2
- EDMONTON 2
- CENTRAL 3
- CALGARY 1
- SOUTHERN ALBERTA 1

QUEBEC 8

- NORTHERN 1
- GATINEAU 1
- MONTREAL AND LAVAL 2
- SOUTHSHORE 2
- QUEBEC CITY 2

SASKATCHEWAN 5

- NORTHERN 2
- SOUTHERN 3

MANITOBA 4

- WEST 1
- EAST 3

ATLANTIC CANADA 5

- NEW BRUNSWICK 2
- NOVA SCOTIA AND PEI 1
- NEWFOUNDLAND 2



INVENTORY MANAGEMENT



PRODUCT KNOWLEDGE



PRODUCT SELECTION

WHERE THE CUSTOMER COMES FIRST





Table of Contents

Tire Repair Material	Pages 7-31
Tire Repair Tools	Pages 32-39
Tire Pressure Monitoring Systems	Pages 40-51
Wheel Weights	Pages 52-65
Valves	Pages 66-86
Air Tools and Accessories	Pages 88-103
Retread/Section Equip't and Supplies	Pages 104-118
Wheel Service Tools and Accessories	Pages 119-135
Tire Changing Tools and Accessories	Pages 136-156
Air Line Fittings and Accessories	Pages 157-162
Jacks and Accessories	Pages 163-171
Impact Sockets	Pages 172-180
Air Inflation Tools and Accessories	Pages 181-202
Shop Equip't Accessories and Parts	Pages 203-227
Tire Service Chemicals and Lubricants	Pages 228-239
Tire Storage Systems	Pages 240-242
Tire Service Tools and Accessories	Pages 243-252
Shop Supplies	Pages 253-269
Part Number index.....	Pages 270-280
Alphabetical Product Index.....	Pages 281-284

Advertiser's Index

AME International.....	2, 49, 156
B&J Rocket America.....	39
Dill Air Controls.....	42
Schrader International.....	45
Bartec USA.....	48
ATEQ Canada.....	51
Perfect Equipment.....	65
Counteract.....	87
Ingersoll Rand.....	97
Chicago Pneumatic.....	102
Magnum Plus.....	120
Gaither Tool Company.....	146
AC Hydraulics.....	165
The Main Resource.....	202
Shrader Canada.....	237
Slip-N-Grip.....	253



Tire And Wheel Service Solutions.



Tire Repair Material





COMBI & STEM REPAIR

Prema Combi Repair Units Can Be Used For Crown Injuries Only. Prepare The Injury Using The Appropriate Prema Carbide Cutter. The Prema Combi Repair Comes With A Guide Wire, Fills And Seals The Injury And Repairs The Inner liner All In One Step. Install With Prema Ultra Fast Dry Vulcanizing Cement. Note: The Prema Combi May Only Be Used When The Angle Of The Injury Is Less Than 25 Degrees. If The Injury Angle Is Greater Than 25 Degrees, Repair With The Appropriate Two - Piece Stem And Repair Unit.

Code	Description	Injury Size	Qty
PC - 1	Prema Combi #1	1/16"	40 Box
PC - 2	Prema Combi #2	1/8"	15 Box
PC - 2J	Prema Combi #2	1/8"	40 Box
PC - 3	Prema Combi #3	1/4"	10 Box
PC - 3J	Prema Combi #3	1/4"	20 Box
PC - 4	Prema Combi #4	3/8"	10 Box
PC - 2	Prema Stem #2	1/8"	20 Box
PC - 3	Prema Stem #3	1/4"	20 Box
PC - 4	Prema Stem #4	3/8"	20 Box
PC - 5	Prema Stem #5	1/2"	20 Box



PC - 2

Note: Prema Combis Must Only Be Used When The Angle Of The Injury Is Less Than 25 Degrees.

RADIAL REPAIR PASSENGER & TRUCK

Prema Centre - Over - Injury Repair Units Are Designed For Use In The Crown, Shoulder And Sidewall Of Radial Tires. They Can Be Installed By Either Chemical (Cold) Vulcanizing Or Heat And Pressure (Hot) Methods. For Cold Application, Install Using Prema Ultra Fast Dry Vulcanizing Cement. Note: PR - 115 Is Used In Place Of PR - 110 In Heavy Duty Applications. PR - 113 Is Used In Place Of PR - 112 Heavy Duty Applications. Note: Refer To The Prema Repair Charts On Page 16 For The Proper Selection Of The Repair Unit. Always Fill The Injury Channel.

Code	Description	W	L	Qty
PR - 109	Prema Radial Repair 109	2"	3"	20 Box
PR - 110	Prema Radial Repair 110	2 - 1/4"	3 - 1/4"	20 Box
PR - 110B	Prema Radial Repair 110 Bulk	2 - 1/4"	3 - 1/4"	80 Box
PR - 115	Prema Radial Repair 110 HD	3"	4 - 1/4"	10 Box
PR - 112	Prema Radial Repair 112	3"	4 - 1/4"	10 Box
PR - 112B	Prema Radial Repair 112 Bulk	3 - 1/4"	5"	40 Box
PR - 113	Prema Radial Repair 112 HD	3 - 1/2"	5 - 1/4"	10 Box
PR - 114	Prema Radial Repair 114	3"	3 - 1/4"	10 Box
PR - 120	Prema Radial Repair 120	3 - 3/4"	5"	10 Box
PR - 122	Prema Radial Repair 122	3 - 3/4"	7"	10 Box
PR - 124	Prema Radial Repair 124	3 - 3/4"	8 - 3/4"	10 Box
PR - 125	Prema Radial Repair 125	3 - 1/4"	10 - 3/4"	10 Box
PR - 126	Prema Radial Repair 126	4 - 3/4"	5 - 1/4"	10 Box
PR - 135	Prema Radial Repair 135	5 - 1/2"	7 - 1/2"	10 Box
PR - 140	Prema Radial Repair 140	4 - 1/4"	7 - 3/4"	10 Box
PR - 142	Prema Radial Repair 142	5 - 1/2"	10 - 3/4"	5 Box
PR - 144	Prema Radial Repair 144	5 - 1/2"	13 - 1/4"	5 Box



PR - 140



RADIAL HYBRID REPAIR PASSENGER & TRUCK

Prema Hybrid Repair Units Combine The Best Of Both Soft Gum And Hard Gum Technologies. Prema Hybrid Centre - Over - Injury Repairs Are Designed For Use In The Crown, Shoulder And Sidewall Of Radial Tires. They Can Be Installed By Either Chemical (Cold) Vulcanizing Or Heat And Pressure (Hot) Methods. For Cold Application, Install Using Prema Ultra Fast Dry Vulcanizing Cement. Note: PRN - 115 Is Used In Place Of PRN - 110 In Heavy Duty Applications. Note: Refer To The Prema Repair Charts For The Proper Selection Of The Repair Unit. Always Fill The Injury Channel.

Code	Description	W	L	Qty
PRN - 110	Prema Hybrid Radial Repair 110	2 - 1/4"	3 - 1/4"	20 Box
PRN - 110B	Prema Hybrid Radial Repair 110 Bulk	2 - 1/4"	3 - 1/4"	80 Box
PRN - 112B	Prema Hybrid Radial Repair 112 Bulk	4 - 3/4"	3"	40 Box
PRN - 115	Prema Hybrid Radial Repair 115	3"	3 - 1/4"	10 Box
PRN - 120	Prema Hybrid Radial Repair 120	3 - 3/4"	5"	10 Box
PRN - 122	Prema Hybrid Radial Repair 122	3 - 3/4"	7"	10 Box
PRN - 124	Prema Hybrid Radial Repair 124	3 - 3/4"	8 - 3/4"	10 Box
PRN - 125	Prema Hybrid Radial Repair 125	4 - 3/4"	5 - 1/4"	10 Box
PRN - 135	Prema Hybrid Radial Repair 135	5 - 1/2"	7 - 1/2"	10 Box
PRN - 140	Prema Hybrid Radial Repair 140	4 - 1/4"	7 - 3/4"	10 Box
PRN - 142	Prema Hybrid Radial Repair 142	5 - 1/2"	10 - 3/4"	5 Box
PRN - 144	Prema Hybrid Radial Repair 144	5 - 1/2"	13 - 1/4"	5 Box



PRN - 125

RADIAL REPAIR AGRICULTURAL

Prema Agricultural Radial Repair Units Are Designed For The Extreme Flexing Of Radial Rear Farm Tires. These Repair Units Can Be Used For Repairing Crown, Shoulder And Sidewall Injuries. Install With Prema Ultra Fast Dry Vulcanizing Cement. Refer To The Prema Radial Repair Chart on page 13 For Proper Selection Of The Repair Unit. Always Fill The Injury Channel.

Code	Description	W	L	Qty
PR - 180	Prema Agricultural Radial Repair 180	6 - 1/4"	8"	5 Box
PR - 182	Prema Agricultural Radial Repair 182	7 - 3/4"	9 - 3/4"	5 Box
PR - 184	Prema Agricultural Radial Repair 184	8 - 3/4"	12"	2 Box
PR - 186	Prema Agricultural Radial Repair 186	10"	13 - 3/4"	1 Box



PR - 180

BIAS REPAIR PASSENGER & TRUCK

Prema Bias Repairs Are Designed With Large Ply Construction For Repairing All Bias Ply Tube And Tubeless Tires. These Repairs Can Be Used For Repairing Crown, Shoulder And Sidewall Injuries. Install With Prema Ultra Fast Dry Vulcanizing Cement. Refer To Prema Bias Ply Repair Chart On Page 13 For Proper Repair Unit Selection. Always Fill The Injury Channel.

Code	Description	W	L	Qty
PB - 1	Prema Bias Repair 1	2 - 1/4"	2 - 1/4"	25 Box
PB - 2	Prema Bias Repair 2	3 - 1/4"	3 - 1/4"	10 Box
PB - 3	Prema Bias Repair 3	3 - 3/4"	3 - 3/4"	10 Box
PB - 4	Prema Bias Repair 4	4 - 3/4"	4 - 3/4"	10 Box
PB - 5	Prema Bias Repair 5	4 - 3/4"	4 - 3/4"	10 Box
PB - 6	Prema Bias Repair 6	6 - 1/2"	6 - 1/2"	10 Box
PB - 7	Prema Bias Repair 7	9 - 3/4"	9 - 3/4"	5 Box
PB - 8	Prema Bias Repair 8	11 - 3/4"	11 - 3/4"	5 Box
PB - 9	Prema Bias Repair 9	13 - 3/4"	13 - 3/4"	5 Box
PB - 10	Prema Bias Repair 10	15 - 3/4"	15 - 3/4"	5 Box
PB - 11	Prema Bias Repair 11	17 - 3/4"	17 - 3/4"	5 Box



PB - 2

**BIAS HYBRID REPAIR PASSENGER AND TRUCK**

Prema Bias Repair Units Are Designed With Large Ply Construction For Repairing All Bias Ply Tube And Tubeless Tires. These Repairs Can Be Used For Repairing Crown, Shoulder And Sidewall Injuries. Install With Prema Ultra Fast Dry Vulcanizing Cement. Refer To Prema Bias Ply Repair Chart On Page 13 For Proper Repair Unit Selection. Always Fill The Injury Channel.

Code	Description	W	L	Qty
PBN - 3	Prema Hybrid Bias Repair	3 - 3/4"	3 - 3/4"	10 Box
PBN - 4	Prema Hybrid Bias Repair	4 - 3/4"	4 - 3/4"	10 Box
PBN - 6	Prema Hybrid Bias Repair	6 - 1/2"	6 - 1/2"	10 Box
PBN - 7	Prema Hybrid Bias Repair	9 - 3/4"	9 - 3/4"	5 Box

BIAS REPAIR AGRICULTURAL

Prema Bias Agricultural Repair Units Are Designed For Use In All Types Of Farm Implement Bias Tires. These Repair Units Can Be Used For Repairing Crown, Shoulder And Sidewall Injuries. Install With Prema Ultra Fast Dry Vulcanizing Cement. Refer To The Bias Repair Chart On Page 13 For Proper Selection Of The Repair Unit. Always Fill The Injury Channel.

Code	Description	W	L	Qty
PBT - 0	Prema Bias Repair Agricultural 0	7 - 3/4"	7 - 3/4"	5 Box
PBT - 1	Prema Bias Repair Agricultural 1	8 - 3/4"	8 - 3/4"	5 Box
PBT - 2	Prema Bias Repair Agricultural 2	10 - 3/4"	10 - 3/4"	5 Box
PBT - 3	Prema Bias Repair Agricultural 3	14 - 1/4"	14 - 1/4"	5 Box
PBT - 4	Prema Bias Repair Agricultural 4	8 - 3/4"	8 - 3/4"	5 Box
PBT - 5	Prema Bias Repair Agricultural 5	10 - 3/4"	10 - 3/4"	5 Box
PBT - 6	Prema Bias Repair Agricultural 6	14 - 1/4"	14 - 1/4"	5 Box
PBT - 7	Prema Bias Repair Agricultural 7	20 - 1/2"	20 - 1/2"	5 Box



PBN - 6



PBT - 1

HYBRID UNIVERSAL REPAIR

Prema Hybrid Universal Repair Units Combine The Best Of Both Soft Gum And Hard Gum Technologies. Prema Hybrid Universal Tire Repairs Are Designed For Repairing Nail Hole Injuries In Tubeless Bias And Radial Tires In The Crown Area Only. These Repair Units Are Available In Either Round Or Square Versions. Install With Prema Ultra Fast Dry Vulcanizing Cement. Always Fill The Injury Channel.

Code	Description	W	L	Diameter	Qty
PURF - 1	Prema Hybrid Universal Round Repair 1			1 - 1/4"	100 Box
PURF - 1T	Prema Hybrid Universal Round Repair 1T			1 - 1/4"	500 Box
PURF - 2	Prema Hybrid Universal Round Repair 2			2	50 Box
PURF - 2T	Prema Hybrid Universal Round Repair 2T			2	100 Box
PURF - 3	Prema Hybrid Universal Round Repair 3			3	50 Box
PURF - 3T	Prema Hybrid Universal Round Repair 3T			3	100 Box
PUSF - 2	Prema Hybrid Universal Square Repair 2	1 - 3/4"	1 - 3/4"		100 Box
PUSF - 2T	Prema Hybrid Universal Square Repair 2T	1 - 3/4"	1 - 3/4"		200 Box
PUSF - 3	Prema Hybrid Universal Square Repair 3	2 - 1/4"	2 - 1/4"		100 Box
PUSF - 3T	Prema Hybrid Universal Square Repair 3T	2 - 1/4"	2 - 1/4"		200 Box



PURF - 1T

**UNIVERSAL REPAIR**

Prema Universal Tire Repair Are Designed For Repairing Nail Hole Injuries In Tubeless Bias And Radial Tires In The Crown Area Only. These Repairs Are Available In Either Round Or Square Versions. Install With Prema Ultra Fast Dry Vulcanizing Cement. Always Fill The Injury Channel With The Appropriate Prema Repair Material.

Code	Description	Diameter	W	L	Qty
PUR - 2	Prema Universal Round Repair 2	2"			50 Box
PUR - 3	Prema Universal Round Repair 3	3"			50 Box
PUS - 2	Prema Universal Square Repair 2				100 Box
PUS - 3	Prema Universal Square Repair 3		1 - 3/4"	1 - 3/4"	100 Box
PUS - 4	Prema Universal Square Repair 4		2 - 1/4"	2 - 1/4"	50 Box



PUR - 2

TUBE REPAIR

Prema Tube Repair Units Are Used To Repair Tubes. Use A Repair Unit At Least 1/2" Inch (12 mm) Larger Than The Injury On Each Side. Install With Prema Ultra Fast Dry Vulcanizing Cement. Note: "Button - Hole" The Injury Prior To Repairing To Prevent The Injury From Continuing To Grow

Code	Description	Diameter	W	L	Qty
PT - 1	Prema Mini Round Tube Repair 1	1 - 1/2"			50 Box
PT - 2	Prema Small Round Tube Repair 2	1 - 3/4"			40 Box
PT - 2B	Prema Small Round Tube Repair 2 Bulk	1 - 3/4"			160 Box
PT - 3	Prema Medium Round Tube Repair 3	2 - 1/4"			40 Box
PT - 3B	Prema Medium Round Tube Repair 3 Bulk	2 - 1/4"			100 Box
PT - 4	Prema Large Round Tube Repair 4	3"			25 Box
PT - 4B	Prema Large Round Tube Repair 4 Bulk	3"			75 Box
PT - 5	Prema Maxi Round Tube Repair 5	4 - 1/2"			10 Box
PT - 6	Prema Giant Round Tube Repair 6	5"			10 Box
PT - 7	Prema Small Oval Tube Repair 7		3"	1 - 1/2"	25 Box
PT - 8	Prema Medium Oval Tube Repair 8		3 - 3/4"	1 - 3/4"	20 Box
PT - 9	Prema Large Oval Tube Repair 9		6"	3"	10 Box
PT - 10	Prema Giant Oval Tube Repair 10		7 - 1/2"	3 - 3/4"	10 Box
PT - 11	Prema Giant Rim Tube Repair 11		9 - 1/2"	2 - 1/2"	10 Box



PT - 1

VULCANIZING CHEMICALS

Prema Ultra Fast Vulcanizing Cement Is Formulated To Provide Outstanding Performance When Used In Conjunction With Prema Tire Repair Materials. Contains No Ozone - Depleting Chemicals. (Flammable)

Code	Description	Qty
PFC - 10ML	Prema Vulcanizing Cement In Tube	10 ml
PFC - 8	Prema Vulcanizing Cement With Brush Top Can	8 oz
PIV - 9FT	Prema Vulcanizing Cement Squeeze Bottle	9 oz
PFC - 32	Prema Vulcanizing Cement Large Can	32 oz



PFC - 8



PIV - 9FT

PRE - BUFFING CLEANERS

Prema Pre - Buffing Cleaner Is Formulated To Remove Contaminants (Such As Silicone And Mold Lubricants) From The Inner liner Of The Tire Prior To Buffing. Available In Either Liquid Or Aerosol. Contains No Ozone - Depleting Chemicals.

Code	Description	Qty
PPC - 16	Prema Pre - Buffing Aerosol Liquid Cleaner	16 oz
PPC - 32	Prema Pre - Buffing Cleaner	32 oz
PPC - 1G	Prema Pre - Buffing Liquid Cleaner	128 oz



PPC - 32 PPC - 16 PPC - 1G



REPAIR FINISHING

Prema Inner liner Over Buffing Sealant Is Designed To Restore Air Retention Qualities To The Buffed Inner liner Around The Repair After Installations. It Can Be Used In Both Cold And Hot Vulcanizing Systems. Contains No Ozone - Depleting Chemicals

Code	Description	Qty
PLOS - 16	Prema Over Buffing Sealant	16 oz



PLOS - 16

Use Prema Tire Talc When Repairing Or Changing Tube Type Tires. Helps Prevent Tubes From Sticking Chafing And Pinching

Code	Description	Qty
PTT - 1	Prema Tire Talc - 1lb Shaker Can	1lb



PTT - 1

EMERGENCY TEMPORARY REPAIRS

Prema Offers A Variety Of Emergency Rubber And Fiber Reinforced Inserts For Filling The Injury In All Types Of Tubeless Tires. Install With Prema Insert Cement. Note: Proper Tire Repair Demands Removal Of The Tire From The Rim And Inspection Of The Damage Before Installation Of A Repair Unit And/Or Filler Material. When A Tire Is Repaired From The Outside Only, It Is Considered An Emergency Repair And Must Be Replaced By An Industry Standard Tire Repair As Soon As Possible.

Code	Description	Length	Qty
PRI - 1	Prema Emergency Reinforced Thin Insert	3 - 3/4"	50 Box
PRI - 2	Prema Emergency Reinforced Regular Insert	3 - 3/4"	50 Box
PRI - 3	Prema Emergency Reinforced Truck Insert	5 - 1/8"	40 Box
PRI - 4	Prema Emergency Reinforced Truck Insert	7 - 1/2"	25 Box



PRI - 1

EMERGENCY TEMPORARY KITS

Prema Offers A Variety Of Emergency Rubber And Fiber Reinforced Inserts For Filling The Injury In All Types Of Tubeless Tires. Install With Prema Insert Cement. Note: Proper Tire Repair Demands Removal Of The Tire From The Rim And Inspection Of The Damage Before Installation Of A Repair Unit And/Or Filler Material. When A Tire Is Repaired From The Outside Only, It Is Considered An Emergency Repair And Must Be Replaced By An Industry Standard Tire Repair As Soon As Possible.

Code	Description
PRI - ATV	Prema Emergency ATV Kit

Contents: PRI - ATV

One chrome T - Handle Cementing Tool, One chrome T - Handle Insert Tool, 50 PRI - 1 Inserts, Rubber Cement (4 Tubes).

*All items come in a sturdy ABS plastic case.



PRI - ATV



EMERGENCY TEMPORARY KITS AND REPAIR

Prema Offers A Variety Of Emergency Rubber And Fiber Reinforced Inserts For Filling The Injury In All Types Of Tubeless Tires. Install With Prema Insert Cement. Note: Proper Tire Repair Demands Removal Of The Tire From The Rim And Inspection Of The Damage Before Installation Of A Repair Unit And/Or Filler Material. When A Tire Is Repaired From The Outside Only, It Is Considered An Emergency Repair And Must Be Replaced By An Industry Standard Tire Repair As Soon As Possible.

Code Description

PRI - 2K Reinforced Insert Passenger Kit Includes an Assortment of PRI - 1 and PRI - 2 Inserts

PRI - 3K Reinforced Insert Truck Kit Includes PRI - 3 Inserts

Contents: PRI - 2K

- 50 - PRI - 1 Inserts
- 50 - PRI - 2 Inserts
- Prema Insert Cement With Flip Top Bottle
- 1 - Spiral Cement Tool
- 1 - Valve Core Tool
- 1 - Dual Foot Air Gauge
- 1 - White Crayon
- 1 - Pistol Grip Inserting Tool

* All Items Listed Above Come In A Durable Plastic Case

Contents: PRI - 3K

- 40 - PRI - 3 Inserts
- Prema Insert Cement With Flip Top Bottle
- 1 - Spiral Cement Tool
- 1 - Valve Core Tool
- 1 - Dual Foot Air Gauge
- 1 - White Crayon
- 1 - Truck Pistol Grip Inserting Tool

* All Items Listed Above Come In A Durable Plastic Case



PRI - 3K



PRI - 2K

REPAIR CABINETS

Prema Cabinets For Storing And Organizing Your Tire Repair Materials, Tool And Chemicals

Code Description

PCAB - 1 Cabinet With Lock And Key

PCAB - STARTUP Prema Startup Tire Repair Kit

Contents:

- 1 - PCAB - 1 1 - 974
- 1 - IR - 327LS 1 - 2 - 936
- 1 - RH100 - S 1 - 2 - 933
- 1 - SLP - 9211 1 - 2 - 9L5
- 1 - PCC - 2P 1 - PC - 3
- 3 - PC - 2 1 - PCC - 3P
- 1 - PFC - 8 1 - SLP - 9216
- 1 - PPC - 16 1 - 940
- 1 - PLOS - 16 1 - PBS - 32
- 1 - SLP - 9215 1 - 80250
- 1 - PP - RMC 1 - PP - RMC



PCAB - 1



PCAB - STARTUP

Repairing Tires The Right Way!

STEP 1 **Inspect**

- Angle of injury must be no greater than 25°
- Injury must be less than 1" for passenger and 1.5" for medium truck
- Injury must be in crown area
- Reject tire for repair if any of the following are found:
 - Broken or separated belts
 - Less than 2/32" tread depth
 - Stud rubber tires down to steel
 - Broken or hooked beads
 - Weather cracking beyond 2/32" deep
 - Linear separations too large for repair
 - Injuries beyond chart limits
 - Run flat conditions
 - Cuts or broken radial body cables on inside shoulder
 - Soft, spongy rubber on inside shoulder

STEP 2 **Pre-Clean**

- Apply **Prema**™ Preball Cleaner to the repair area
- Scrape contaminants from tire liner
- Repeat 2-3 times

STEP 3 **Buff & Cut**

- Mark area 1/2" around repair hole as a guide
- Buff within marked area with clean, sharp, fine grit wheel on a slow speed buffer (3,000 rpm max)
- Remove tire damage by cutting it out with the appropriate carbide cutter on a slow speed drill (1,200 rpm max)
- Drill from inside 3 times, then from outside 3 times

STEP 4 **Post-Clean**

- Brush rubber dust and metal filings from buffed surface to prevent contamination
- Vacuum rubber dust and metal filings from inside the tire

STEP 5 **Install**

- Apply **Prema**™ Ultra Fast Dry Vulcanizing Cement to injury channel using spiral tool
- Apply a thin even coat of Vulcanizing Cement to the buffed area and allow to dry completely (3-5 minutes)
- Remove poly from **Prema**™ Repair Ball, making sure not to touch the dry vulcanizing gum
- Pull the repair stem through the injury from the inside of the tire until the repair head seats as the liner, making sure not to damage the repair ball

STEP 6 **Finish**

- Firmly stick the repair ball to remove trapped air
- Remove the clear poly from the repair ball
- Apply **Prema**™ Liner Overball Cement to the overbuffed area of the liner
- Cut the stem 1/8" above the tread surface
- Re-mount the tire and check for leaks

PREMA

Taking Care
of Your Tires.



BIAS REPAIR PASSENGER / LIGHT TRUCK

"C" Maximum Injury Size		Tread, Shoulder, and Sidewall Repairs PLY RATING (LOAD RANGE)										
in	mm	4 (B)	6 (C)	8 (D)	10 (E)	12 (F)	14 (G)	16 (H)	18 (J)	20 (L)	22 (M)	24 (N)
1/8	3	PB-1	PB-1	PB-1	PB-1	PB-1	PB-1	PB-1	PB-1	PB-1	PB-1	PB-1
1/4	6	PB-1	PB-1	PB-1	PB-2	PB-2	PB-2	PB-2	PB-2	PB-2	PB-2	PB-2
3/8	10	PB-2	PB-2	PB-3	PB-3	PB-3	PB-3	PB-5	PB-5	PB-5	PB-5	PB-5
1/2	13	PB-3	PB-3	PB-3	PB-3	PB-5	PB-5	PB-5	PB-6	PB-6	PB-7	PB-7
3/4	20	PB-3	PB-3	PB-3	PB-3	PB-5	PB-5	PB-6	PB-6	PB-6	PB-7	PB-7
1	25	PB-4	PB-4	PB-5	PB-5	PB-5	PB-6	PB-6	PB-7	PB-7	PB-8	PB-8
1 1/2	38	PB-5	PB-5	PB-5	PB-6	PB-6	PB-7	PB-7	PB-7	PB-8	PB-9	PB-9
2	50	PB-6	PB-6	PB-6	PB-7	PB-7	PB-7	PB-7	PB-8	PB-9	PB-9	PB-9
2 1/2	63	-	PB-7	PB-7	PB-7	PB-7	PB-8	PB-8	PB-9	PB-9	PB-9	PB-9
3	75	-	-	-	PB-8	PB-8	PB-8	PB-8	PB-9	PB-10	PB-10	PB-10
4	100	-	-	-	PB-9	PB-9	PB-9	PB-9	PB-10	PB-10	PB-11	PB-11
5	125	-	-	-	-	-	PB-11	PB-11	PB-11	PB-11	-	-

BIAS REPAIRS Agricultural & Industrial



"C" Maximum Injury Size		Tread, Shoulder, & Sidewall Repairs PLY RATING (LOAD RANGE)							
inch	mm	4 (B)	6 (C)	8 (D)	10 (E)	12 (F)	14 (G)	16 (H)	18 (J)
1/8	3	PB-1	PB-1	PB-1	PB-1	PB-1	PB-1	PB-1	PB-1
1/4	6	PB-1	PB-1	PB-2	PB-2	PB-2	PB-2	PB-2	PB-2
3/8	10	PB-2	PB-2	PB-3	PB-3	PB-4	PB-5	PB-5	PB-5
1/2	13	PB-3	PB-3	PB-3	PB-3	PB-5	PB-5	PB-5	PB-6
3/4	20	PB-3	PB-3	PB-3	PB-3	PB-5	PB-5	PB-6	PB-6
1	25	PB-4	PB-4	PB-5	PB-5	PB-5	PB-6	PB-6	PB-7
1 1/2	38	PB-5	PB-5	PB-5	PB-6	PB-6	PB-7	PB-7	PBT-2
2	50	PB-6	PB-6	PB-6	PB-7	PB-7	PB-7	PB-7	PBT-3
2 1/2	63	PBT-0	PBT-0	PBT-0	PBT-1	PBT-4	PBT-4	PBT-5	PBT-5
3	75	PBT-0	PBT-0	PBT-0	PBT-1	PBT-4	PBT-5	PBT-5	PBT-6
4	100	PBT-1	PBT-1	PBT-1	PBT-4	PBT-4	PBT-5	PBT-5	PBT-6
5	125	PBT-2	PBT-2	PBT-2	PBT-5	PBT-5	PBT-5	PBT-6	PBT-6
6	38	PBT-2	PBT-2	PBT-2	PBT-5	PBT-5	PBT-6	PBT-6	PBT-6
7	50	PBT-3	PBT-3	PBT-3	PBT-6	PBT-6	PBT-7	PBT-7	PBT-7
8	63	PBT-3	PBT-3	PBT-3	PBT-6	PBT-7	PBT-7	PBT-7	PBT-7
9	75	-	-	PBT-6	PBT-7	PBT-7	PBT-7	-	-
10	100	-	-	PBT-7	PBT-7	PBT-7	-	-	-

Must Be Installed Using Prema Chemicals And Cements. Injury Must Be Filled With Appropriate Prema Repair Materials. Refer To The Prema 2 - Piece Repair Manual Or The Prema Section Repair Manual For More Detailed Repair Information.

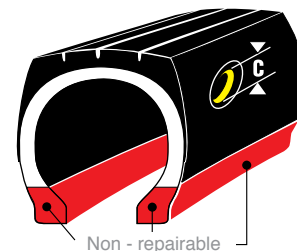
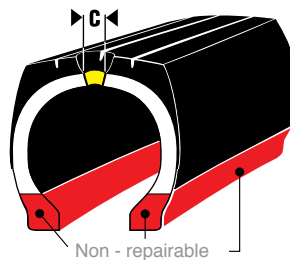



BIAS REPAIRS Giant OTR (Off-The-Road) Chemical



Maximum Injury Size		Tread & Shoulder Repairs TIRE PLY RATING								
		10 - 14	16 - 20	22 - 26	28 - 32	34 - 38	40 - 44	46 - 50	52 - 58	60 - & up
inch	mm									
½	13	1	1	1	1	1HD	1HD	1HD	1HD	1HD
1	25	1	1	1	1HD	1HD	1HD	1HD	2	2
2	50	1	1	1HD	2	2	2	2	3	3
3	75	1	1HD	2	2	2	2HD	3	3HD	4
4	100	2	2	2	2HD	3	3HD	4HD & 2	4 & 2HD	4 & 2HD
5	125	2	2HD	2HD	3	3HD	4HD	4HD & 2	4HD & 3	4HD & 3HD
6	150	2	3	3	3HD	3HD	4 & 2	4 & 3	4 & 3	5 & 4
7	175	2	3	3	3HD	4HD	4 & 2	5 & 3	5HD & 3	5HD & 3
8	200	-	3	4	4HD	5HD	4HD & 2	5 & 4	5HD & 4	6 & 4HD
9	225	-	-	4	4HD	5HD	5 & 3	5HD & 4	6 & 4	6HD & 4
10	250	-	-	4	4HD	5 & 2	5 & 3	6 & 4	6HD & 4	6HD & 4HD

Maximum Injury Size		Sidewall Repairs TIRE PLY RATING								
		10 - 14	16 - 20	22 - 26	28 - 32	34 - 38	40 - 44	46 - 50	52 - 58	60 - & up
inch	mm									
½	13	1	1	1	1	1HD	1HD	1HD	1HD	1HD
1	25	1	1	1	1HD	1HD	1HD	1HD	2	2
2	50	1	1	1	1HD	2	2	2	3	3
3	75	1	1HD	2	2	2	2HD	3	3HD	7
4	100	2	2	2	2HD	3	3HD	4S & 2HD	4 & 2HD	4 & 2HD
5	125	2	2HD	2HD	3	3HD	7HD	4S & 2HD	4SHD & 3	4SHD & 3HD
6	150	2	3	3	3HD	3HD	4S & 2	4SHD & 3	4SHD & 3	5S & 7
7	175	2	3	3	3HD	4SHD	4SHD & 2	5SHD & 3	5SHD & 3	5SHD & 7
8	200	-	3	7	7HD	5SHD	4SHD & 2	5S & 4S	5SHD & 7	6S & 4SHD

Notes: The numbers in each column (under the Tire Ply Rating) refer to the appropriate Prema Bias Giant Repair, i.e. - for a four (4) inch Injury on a Tire With a 32 ply rating, the correct Repair for the Tread And Shoulder area Would be a PBag - 2HD and for the Sidewall area Would also a PBag - 2HD; for a seven (7) inch Injury on a Tire rated at 38 plies, the correct Repair for the Tread And Shoulder area Would be a PBag - 4HD and for the Sidewall area Would be a PBag - 7HD. Where 2 Different Repair are listed (such as 3HD And 2), the smaller Repair is installed on the top side of the Larger Repair. This is done in order to have Flexible Repair and still restore the Tire to the original or better ply strength. **The Prema Giant OTR Chemical Repair System**, for both Radial and Bias Repair, requires that these Repair be installed using Prema Gray Self - Vulcanizing Floater Gum and Prema Giant (OTR) Ultra Fast Dry Vulcanizing Cement. The Injury must be removed and filled in accordance to the Prema Giant OTR Repair Manual prior to the installation of the Repair.



BIAS REPAIRS OTR (Off-The-Road) Cloth Back



Maximum Injury Size		Tread, Shoulder, & Sidewall Repairs PLY RATING										
inch	mm	6 - 8	10 - 12	14 - 16	18 - 20	22 - 24	26 - 28	30 - 36	38 - 44	46 - 50	52 - 58	60 +
½	13	PBOR-1	PBOR-1	PBOR-1	PBOR-2	PBOR-2	PBOR-2	PBOR-2	PBOR-2	PBOR-2	PBOR-2	PBOR-3
1	25	PBOR-2	PBOR-2	PBOR-2	PBOR-2	PBOR-2	PBOR-2	PBOR-2	PBOR-2	PBOR-3	PBOR-3	PBOR-4
1½	38	PBOR-2	PBOR-2	PBOR-2	PBOR-2	PBOR-2	PBOR-3	PBOR-3	PBOR-3	PBOR-4	PBOR-4	PBOR-5
2	50	PBOR-2	PBOR-2	PBOR-3	PBOR-3	PBOR-3	PBOR-3	PBOR-3	PBOR-3	PBOR-4	PBOR-4	PBOR-5
2½	63	PBOR-2	PBOR-2	PBOR-3	PBOR-3	PBOR-3	PBOR-4	PBOR-4	PBOR-4	PBOR-5	PBOR-5	PBOR-6
3	75	PBOR-3	PBOR-3	PBOR-4	PBOR-4	PBOR-4	PBOR-5	PBOR-5	PBOR-6	PBOR-6	PBOR-6	PBOR-7
4	100	-	PBOR-4	PBOR-4	PBOR-4	PBOR-5	PBOR-5	PBOR-6	PBOR-6	PBOR-7	PBOR-7	PBOR-8
5	125	-	-	PBOR-4	PBOR-5	PBOR-5	PBOR-6	PBOR-6	PBOR-7	PBOR-8	PBOR-8	PBOR-8
6	150	-	-	PBOR-5	PBOR-5	PBOR-6	PBOR-7	PBOR-7	PBOR-8	PBOR-8	PBOR-8	PBOR-9
7	175	-	-	-	PBOR-6	PBOR-7	PBOR-7	PBOR-8	PBOR-8	PBOR-9	PBOR-10	PBOR-10
8	200	-	-	-	-	PBOR-7	PBOR-8	PBOR-9	PBOR-9	PBOR-10	PBOR-10	PBOR-11
9	225	-	-	-	-	PBOR-8	PBOR-8	PBOR-9	PBOR-9	PBOR-10	PBOR-11	PBOR-11
10	250	-	-	-	-	-	PBOR-9	PBOR-9	PBOR-10	PBOR-11	PBOR-11	PBOR-11

BIAS REPAIRS OTR (Off-The-Road) Cloth Back



Maximum Injury Size		Tread Repairs ONLY PLY RATING										
inch	mm	6 - 8	10 - 12	14 - 16	18 - 20	22 - 24	26 - 28	30 - 36	38 - 44	46 - 50	52 - 58	60 +
11	275	-	-	-	-	-	PBOR-9	PBOR-10	PBOR-10	PBOR-11	PBOR-12	PBOR-12
12	300	-	-	-	-	-	PBOR-10	PBOR-10	PBOR-10	PBOR-12	PBOR-12	PBOR-12

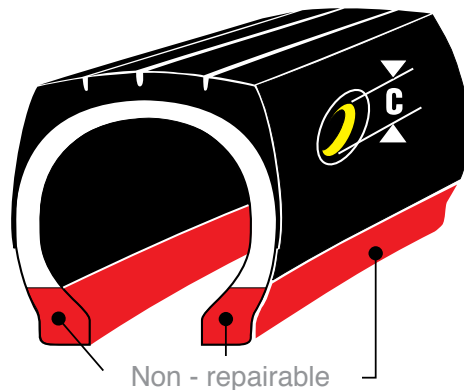
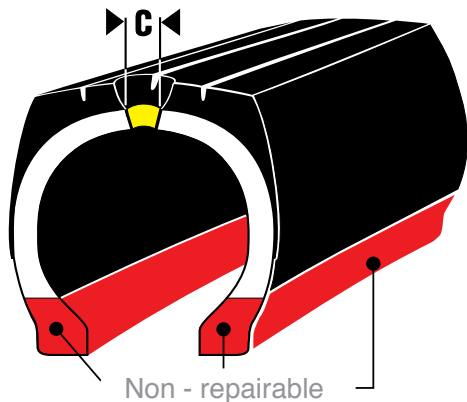



RADIAL - TRUCK



Sidewall Injury				
1		Truck Tire Sizes (tubeless unless indicated)		
Injury Size		6.50-12.50 (tube type)	7.50 - 10.00 (tube type)	11.00 - 14.00 (tube type)
Width	Length	7 - 10 215/85 - 255/85 215/75 - 265/75	8 - 11 235/80 - 275/80 245/75 - 295/75	12 - 16.5 295/80 - 315/80 315/75 - 425/65
in	mm	PR-	PR-	PR-
1/8	3	110	110	110
1/4	6	110	110	112
1 Cable	1 1/2 40	120	120	120
1 Cable	3/8 80	122	122	122
1 Cable	4 3/4 120	-	124	124
1 Cable	6 150	-	126	126
2 Cables	3/4 20	120	120	122
2 Cables	1 1/2 40	120	122	124
2 Cables	2 3/8 60	122	124	126
2 Cables	5 1/8 130	-	126	126
3/8	10	120	126	140
3/8	10	122	126	140
3/8	10	124	126	142
3/8	10	130	126	144
1/2	15	122	140	140
1/2	15	124	140	142
1/2	15	140	142	142
1/2	15	150	144	144
3/4	20	122	140	140
3/4	20	124	140	142
3/4	20	110	142	144
3/4	20	130	144	144
1	25	140	142	144
1	25	140	142	144
1	25	140	144	144
1 1/4	32	140	142	144
1 1/4	32	140	144	144
1 1/4	32	140	144	144
1 1/2	40	140	144	144
1 1/2	40	140	144	146

Crown Injury				
2		Truck Tire Sizes (tubeless unless indicated)		
Crown Injury Diameter (max.)	6.50-12.50 (tube type)	7.50 - 10.00 (tube type)	11.00 - 14.00 (tube type)	
	7 - 10 215/85 - 255/85 215/75 - 265/75	8 - 11 235/80 - 275/80 245/75 - 295/75	12 - 16.5 295/80 - 315/80 315/75 - 425/65	
in	mm	PR-	PR-	PR-
1/8	3	110/115	110/115	110/115
1/4	6	110/115	112/113	112/113
3/8	10	120	120	120
1/2	15	122	140/125	140/125
3/4	20	122	140/125	142/137
1	25	140/125	142/135	142/137
1 1/4	32	-	142/135	144
1 1/2	40	-	144	144

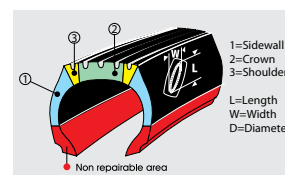

The SHOULDER is defined as 1 1/2 inches (40 mm) in from the outside edge of the tread footprint.

The NON-REPAIRABLE AREA is defined by the tire type/size as listed below.

Tire Type or Size	Inch	mm
Passenger & Light Truck (<1/2 ton)	1 1/2	40
6.50 - 7.00	2 1/2	65
7.50 - 16.00	3	76
17.00 - 23.50	3 1/2	90
24.00 - 29.50	5	125
30.00 - 33.50	6	150
36.00	7 1/2	190
37.00 - 55/80	10	250

Shoulder Injury				
3		Truck Tire Sizes (tubeless unless indicated)		
Shoulder Injury Diameter (max.)	6.50-12.50 (tube type)	7.50 - 10.00 (tube type)	11.00 - 14.00 (tube type)	
	7 - 10 215/85 - 255/85 215/75 - 265/75	8 - 11 235/80 - 275/80 245/75 - 295/75	12 - 16.5 295/80 - 315/80 315/75 - 425/65	
in	mm	PR-	PR-	PR-
1/8	3	112	112	112
1/4	6	120	120	120
3/8	10	120	120	140
1/2	15	140	140	140
3/4	20	-	142	142
1	25	-	144	144
1 1/4	32	-	-	146

Must be installed using PREMA Chemicals and Cements. Injury must be filled with appropriate PREMA repair materials. Refer to the PREMA 2-Piece Repair Manual or the PREMA Section Repair Manual for more detailed repair information.

**RADIAL TIRE REPAIR**

Rema Tip Top Offers A Variety Of Radial - Ply Repair Units To Meet The Diverse Demands Of Today's Passenger, Truck And OTR Applications. Due To Our Fully Integrated Blue Bonding Layer And Centre Over Injury Design, Rema Tip Top Radial - Ply Repair Units Are Suitable For Use With All Current Vulcanizing Systems.

Code	Qty	Description	W	L
RAD - 0	10 Box	Rema Radial Repair 0	1"	9/16"
RAD - 1N	20 Box	Rema Radial Repair 1N	2"	2 - 3/4"
RAD - 110	20 Box	Rema Radial Repair 110	2 - 3/4"	2 - 3/4"
RAD - 115	20 Box	Rema Radial Repair 115	3 - 1/2"	3"
RAD - 116	20 Box	Rema Radial Repair 116	2 - 5/8"	4"
RAD - 120	10 Box	Rema Radial Repair 120	4 - 7/8"	3"
RAD - 122	10 Box	Rema Radial Repair 122	6 - 7/8"	3"
RAD - 124	10 Box	Rema Radial Repair 124	8 - 1/2"	3"
RAD - 125	10 Box	Rema Radial Repair 125	4 - 1/2"	9 - 7/8"
RAD - 126	10 Box	Rema Radial Repair 126	2 - 7/8"	10 - 1/2"
RAD - 128	10 Box	Rema Radial Repair 128	2 - 7/8"	13 - 1/8"
RAD - 135	10 Box	Rema Radial Repair 135	5 - 3/4"	8"
RAD - 140	10 Box	Rema Radial Repair 140	7 - 7/8"	3 - 15/16"
RAD - 142	10 Box	Rema Radial Repair 142	10 - 1/4"	5"
RAD - 144	10 Box	Rema Radial Repair 144	13"	5"
RAD - 145	5 Box	Rema Radial Repair 145	7 - 3/4"	9 - 1/8"
RAD - 146	5 Box	Rema OTR Radial Repair 146	7 - 1/4"	17 - 1/4"
RAD - 150	5 Box	Rema OTR Radial Repair 150	23"	7 - 1/8"
RAD - 152	3 Box	Rema OTR Radial Repair 152	23"	9 - 1/2"
RAD - 155	5 Box	Rema OTR Radial Repair 155	10 - 1/4"	13 - 1/8"
RAD - 156	3 Box	Rema OTR Radial Repair 156	29"	10 - 1/2"
RAD - 160	3 Box	Rema OTR Radial Repair 160	40"	10 - 1/4"
RAD - 162	1 Box	Rema OTR Radial Repair 162	13"	41 - 1/4"
RAD - 165	3 Box	Rema OTR Radial Repair 165	13 - 1/8"	16 - 3/4"
RAD - 168	1 Box	Rema OTR Radial Repair 168	14"	30 - 3/8"
RAD - 175	3 Box	Rema OTR Radial Repair 175	18"	21 - 3/4"
RAD - 185+	1 Box	Rema OTR Radial Repair 185+		
RAD - 180	5 Box	Rema Agricultural Radial Repair 180	7 - 3/4"	6"
RAD - 182	5 Box	Rema Agricultural Radial Repair 182	10"	7 - 1/2"
RAD - 184	5 Box	Rema Agricultural Radial Repair 184	11 - 1/2"	8 - 1/2"
RAD - 186	5 Box	Rema Agricultural Radial Repair 186	13 - /2"	9 - 3/4"
RAD - 188	3 Box	Rema Agricultural Radial Repair 188	17.66"	10.94"
RAD - 190	3 Box	Rema Agricultural Radial Repair 190	21 - 5/8"	12 - 1/4"
RAD - 235	10 Box	Rema Agricultural Radial Repair 235	5 - 1/4"	7 - 1/4"
RAD - 165 - TL - PR		OTR Repair Rad - 165 - TI - Prevent		
RAD - 175 - TL - PR		OTR Repair Rad - 175 - TI - Prevent		
RAD - 185 - TL - PR		OTR Repair Rad - 185 - TI - Prevent		





UNIVERSAL REPAIR

Rema Tip Top's Rubber - Reinforced Universal Repair Units Are Specially Formulated To Provide Maximum Flexibility And Strength. These Non - Directional, Centre Over Injury Repair Units Perform Flawlessly In Both Radial Or Bias - Ply Tire Designs.

Code	Description	W	L	Qty
UP - 3	Rema Universal Round Repair 3	1"	1/4"	100 Box
UP - 4.5P	Rema Universal Square Repair 4.5 Pail	1"	3/4"	300 Box
UP - 6	Rema Universal Square Repair 6	2"	1/4"	50 Box
UP - 6AP	Rema Universal Square Repair 6 Pail	2"	1/4"	200 Box
UP - 8	Rema Universal Square Repair 8	2"	1/2"	50 Box
UP - 8P	Rema Universal Square Repair 8 Pail	2"	3/5"	150 Box



BIAS REPAIR PASSENGER AND TRUCK

Rema Tip Top Offers A Wide Selection Of Bias - Ply (Cross - Ply) Repair Units For Applications On Passenger, Truck, OTR, Agricultural and Industrial Bias - Ply Tires. Due To Our Fully - Integrated Blue Bonding Layer, Rema Tip Top Bias - Ply Repair Units Are Suitable For Use With All Current Vulcanizing Systems. For Best Results, Always Select The Corresponding Rema Tip Top Stem Insert Unit, Carbide Cutter And Special Cement BL (Non - Flammable) Or Special Blue Cement (Flammable) For A Permanent, Reliable Repair.

Code	Description	W	L	Ply	Qty
PN - 0	Rema Bias Repair 0	1"	9/16"	1 Ply	50 Box
PN - 3	Rema Bias Repair 3	4"	1/4"	2 Ply	10 Box
PN - 4	Rema Bias Repair 4	5"	3/4"	2 Ply	10 Box
PN - 5	Rema Bias Repair 5	6"	1/2"	4 Ply	10 Box
PN - 6	Rema Bias Repair 6	9"	1/4"	6 Ply	10 Box
PN - 7	Rema Bias Repair 7	11"	3/4"	6 Ply	10 Box
PN - 8	Rema Bias Repair 8	13"	1/2"	6 Ply	5 Box
PN - 9	Rema Bias Repair 9	15"	1/2"	8 Ply	3 Box
PN - 10	Rema Bias Repair 10	17"	3/4"	8 Ply	3 Box



PN - 04

PN - 03

BIAS - PLY NAIL HOLE PATCHES

Rema Tip Top Offers A Wide Selection Of Bias - Ply Nail Hole Patches (Cross - Ply) Repair Units For Applications On Passenger, Truck, OTR, Agricultural and Industrial Bias - Ply Tires. Due To Our Fully - Integrated Blue Bonding Layer, Rema Tip Top Bias - Ply Repair Units Are Suitable For Use With All Current Vulcanizing Systems. For Best Results, Always Select The Corresponding Rema Tip Top Stem Insert Unit, Carbide Cutter And Special Cement BL (Non - Flammable) Or Special Blue Cement (Flammable) For A Permanent, Reliable Repair.

Code	Description	W	L	Ply	Qty
FRU1 - MP	Ply Patch	2"	1/2"	1 Ply	25 Box
FRU1 - P	Ply Patch	2"	1/2"	1 Ply	100 Box
FRU2 - MP	Ply Patch	3"	1/4"	2 Ply	25 Box
FRU2 - P	Ply Patch	3"	1/4"	2 Ply	100 Box



REMA - STEM

Rema Tip Top's Most Popular Unit For Crown Repair Of Passenger/Light Truck Tires. Our Minicombi's Are Available In A Wide Range Of Sizes And Establish New Standards In One - Piece Repair Technology. For Best Results Always Use With Rema Tip Top Carbide Cutters And Special Cement BL (Non - Flammable) Or Special Blue Cement (Flammable) For A Permanent Repair. Improved Blue Coating Enhances The Bonding Process.

Code	Description	Injury
A - 3	Rema Mini Combi 3	1/8"
A - 3 - R	Rema Mini Combi 3-R, Includes Cement	1/8"
A - 4.5	Rema Mini Combi 4.5	3/16"
A - 6	Rema Mini Combi 6	1/4"
A - 6 - R	Rema Mini Combi 6 Kit, Includes Cement	1/4"
B - 8MC	Rema Mini Combi 3	5/16"
B - 8 - R	Rema Mini Combi 8 Kit, Includes Cement	5/16"
B - 10	Rema Mini Combi 10	3/8"
B - 10 - R	Rema Mini Combi 10 Kit, Includes Cement	3/8"
193	Rema Stem 6	1/4"
194	Rema Stem 8	5/16"
RS - 10	Rema Stem 10	3/8"
RS - 12	Rema Stem 12	1/2"

Advice: Maximum number of repairs carried out with Combi repair inserts in one tire. Always check whether repairs carried out in the tire are defective. Axial distance between repairs: minimum 15cm/6"

Repairable area in -% of the tread width	Speed Index	mm				
		3	4.5	6	8	10
		g = max. damage size				
		A3	A4.5	A6	B8	B10
 -V		●				
 -V		●	●	●		
 ZR-W		●				
 max. LI = 177						
 -80%		●	●	●	●	
 -70%		●	●	●	●	●
 -75%		●	●	●	●	●

3



REMA MINICOMBI INSERTS



BIAS REPAIR AG, OTR AND INDUSTRIAL

Rema Tip Top Offers A Wide Selection Of Bias - Ply (Cross - Ply) Repair Units For Applications On Passenger, Truck, OTR, Agricultural and Industrial Bias - Ply Tires. Due To Our Fully Integrated Blue Bonding Layer, Rema Tip Top Bias - Ply Repair Units Are Suitable For Use With All Current Vulcanizing Systems. For Best Results.

Code	Description	W	Ply	Qty
PN - 20	Rema Agricultural Bias Repair	10"	4 Ply	10 Box
PN - 21	Rema Agricultural Bias Repair	14"	4Ply	5 Box
PN - 22	Rema Agricultural Bias Repair	20"	4 Ply	3 Box
PN - 23	Rema Agricultural Bias Repair	10"	6 Ply	10 Box
PN - 24	Rema Agricultural Bias Repair	14-1/2"	6 Ply	5 Box
PN - 25	Rema Agricultural Bias Repair	20"	6 Ply	3 Box
PN - 40	Rema Industrial Bias Repair 40	7"	4 Ply	2 Box
PN - 41	Rema Industrial Bias Repair 41	8-3/4"	6 Ply	2 Box
PN - 42	Rema Industrial Bias Repair 42	10 -1/4"	8 Ply	2 Box
PN - 050	Rema OTR Bias Repair 50	9-1/2"	4 Ply	10 Box
PN - 050+	Rema OTR Bias Repair 50+	9-1/2"	6 Ply	5 Box
PN - 052	Rema OTR Bias Repair 52	14"	6 Ply	3 Box
PN - 052+	Rema OTR Bias Repair 52+	14"	8 Ply	3 Box
PN - 054	Rema OTR Bias Repair 54	19"	8 Ply	2 Box
PN - 054+	Rema OTR Bias Repair 54+	19"	10 Ply	2 Box
PN - 056	Rema OTR Bias Repair 56	26"	10 Ply	2 Box
PN - 056+	Rema OTR Bias Repair 56+	26"	12 Ply	2 Box
PN - 056S	Rema OTR Bias Repair 56 Sidewall	26"	10 Ply	2 Box
PN - 058	Rema OTR Bias Repair 58	32"	12 Ply	1 Box
PN - 058+	Rema OTR Bias Repair 58+	32"	14 ply	1 Box
PN - 058S	Rema OTR Bias Repair 58 Sidewall	32"	12 ply	1 Box
PN - 058S+	Rema OTR Bias Repair 58 Sidewall+	32"	14 ply	1 Box
PN - 60+	Rema OTR Bias Repair 60+	39-1/4"	16 Ply	1 Box



PN - 20



PN - 050

VULCANIZING CHEMICALS

Specifically Designed For The Vulcanizing Of Tube Patches, Valve Patches And Rubber - Based Tube Valve Repair Units

Code	Description	Size
203CV	Rema Cold Vulcanizing Fluid	8 oz
204CV	Rema Cold Vulcanizing Fluid	32 oz
205CV	Rema Cold Vulcanizing Fluid	128 oz



203CV

The Key To Rema Tip Top's Exclusive Blue Bonding System, Special Cement BL (Non - Flammable) Creates A Nearly Indestructible Bond Between Tire And Repair Unit. Specifically Designed For The Application Of Rema Tip Top Radial, Bias - Ply And Universal, Minicombi And Rema stem Repair Units. Use For Chemical Installation Of Rema Tip Top Blue Bonding Layer Repair Units, Blue Floater Gum And Chemical Vulcanizing Compounds.

Code	Description	Size
BL - 32	Rema Special Blue Cement	32 oz
BL - G	Rema Special Blue Cement	128 oz
BL - 8	Rema Special Blue Cement	8 oz
BL - 8F	Rema Special Blue Cement Flammable	8 oz
BL - 5F	Rema Special Blue Cement Flammable	32 oz
5576	Rema OTR Special Blue Cement	1 kg
5577	Rema OTR Special Blue Cement	4.5 kg



BL - 8



5578

Specially Designed For Heat Cure Repair Processes Utilizing Rema Tip Top Repair Units And Uncured MTR Rubber Products

Code	Description	Size
5578	Rema Thermopress MTR Solution	1 kg
5579	Rema Thermopress MTR Solution	5.4 kg



PRE - BUFFING CLEANERS

Rema Tip Top Pre - Buffing Cleaners (Non - Flammable) Are Specially Formulated To Dissolve Mold - Release Lubricants And Other Contaminants Creating A Clean Surface Prior To Inner liner Buffing. Available In Spout - Top Liquid Or Spray - Top Aerosol Dispensers. Same Formula For Tube Or Tire Preparation.

Code	Description	Size
70	Rema Pre - Buffing Cleaner Aerosol	16 oz
71	Rema Pre - Buffing Cleaner	32 oz
70F	Rema Pre - Buffing Cleaner Aerosol	16 oz
71F	Rema Pre - Buffing Cleaner Flammable	32 oz



70

REPAIR FINISHING

Rema Tip Top Offers Two Distinct Formulations To Accommodate Unique Customer Preference Or Requirements. Properly Applied, Repair Sealer Creates An Airtight Seal Around A Finished Repair, Overbuffed Areas Or Porous Tire Innerliners. Prudent Use Of Repair Sealant Maintains The Integrity Of The Repair.

Code	Description	Size
76	Rema Over Buffing Sealant	16 oz
76G	Rema Over Buffing Sealant	1G
76F	Rema Inner liner Sealant	16 oz (Flammable)



76

Specially Formulated For Trouble - Free Tube Installation, Reduces Folding And Sticking Which Contributes To Friction Within The Tire

Code	Description	Size
63	Rema Tire Talc	1lb



63

BICYCLE REPAIR KIT

Rema Tip Top Offers A Variety Of Two - Wheel Bicycle Repair Kits For Tubes And Tubeless Tires. Rema Tip Top's Feather Edge Patches Results In A Smooth, Seamless Tube Repair, Designed To Eliminate Bulges On High - Pressure Tires

20 - Kit	Rema Bicycle Repair Kit TT05
21 - Kit	Rema Bicycle Repair Kit TT01
22 - Kit	Rema Bicycle Repair Kit TT02

EMERGENCY TEMPORARY KITS AND REPAIR

Rema Tip Top Offers A Variety Of Two - Wheel Bicycle Repair Kits For Tubes And Tubeless Tires. Rema Tip Top's Feather Edge Patches Results In A Smooth, Seamless Tube Repair, Designed To Eliminate Bulges On High - Pressure Tires

Code	Description
26	Rema Emergency Radial Repair Kit
560 - Kit	Rema 50 Seallastic Repair Unit
561 - Refill	Rema Emergency Refill For 560 - Kit
580 - Kit	Rema Emergency OTR Tire Kit 580
581 - Refill	Rema Emergency Refill For 580 - Kit
RAD - 104	Rema Super Radial Emergency Anchor Seal Kit
760 - Kit	Rema 50 Super Radial Anchor Seal Unit
761 - Refill	Rema Emergency Refill For 761 - Kit
9	Rema TR15 Tube Replacement Valve .625"
9A	Rema 3 - 1/4" Screw - On Spud Tube Valve









RAD - 104



Rema Tire Repair Materials

RAD 100 Series Section Repair Chart

 max. A mm max. R mm max. A inch max. R inch	 max. A mm max. R mm max. A inch max. R inch	 max. A mm max. R mm max. A inch max. R inch	RAD No.	 max. C Ø mm max. A x R mm		 max. C Ø inch max. A x R inch		 max. S mm max. S inch		
				max. C Ø mm	max. A x R mm	max. C Ø inch	max. A x R inch	max. S mm	max. S inch	
-	-	-	115	8	8 x 8	3/8	3/8 x 3/8	-	-	
6	10	1/4	3/8	120	10	10 x 15	3/8	3/8 x 5/8	8	3/8
10	80	3/8	3 1/4	140	20	20 x 40	3/4	3/4 x 1 5/8	15	5/8
20	60	3/4	2 3/8							
10	110	3/8		142	30	30 x 50	1 1/4	1 1/4 x 1 1/4	20	3/4
25	80	1	3 1/4							
20	130	3/4		144	40	40 x 70	1 5/8	1 5/8 x 2 3/4	25	1
40	80	1 5/8	3 1/4							
-	-	-	-	125	15	15 x 25	5/8	5/8 x 1	-	-
-	-	-	-	135	25	25 x 35	1	1 x 1 3/8	-	-
-	-	-	-	145	40	40 x 60	1 5/8	1 5/8 x 2 3/8	-	-
1 Cable	80	1 Cable	3 1/4	124	-	-	-	-	-	-
2 Cables	60	2 Cables	2 3/8							
1 Cable	120	1 Cable	4 3/4	126	-	-	-	-	-	-
3 Cables	60	3 Cables	2 3/8							
-	-	-	-	115	8	8 x 8	3/8	3/8 x 3/8	-	-
6	6	1/4	1/4	120	10	10 x 10	3/8	3/8 x 3/8	6	1/4
10	60	3/8	2 3/8	140	15	15 x 20	5/8	5/8 x 5/8	10	3/8
15	35	5/8	1 3/8							
10	100	3/8	4	142	25	25 x 50	1	1 x 1	20	3/4
25	80	1	3 1/4							
20	130	3/4	5 1/4	144	40	40 x 70	1 5/8	1 5/8 x 1 5/8	25	1
40	80	1 5/8	3 1/4							
-	-	-	-	125	10	10 x 20	3/8	3/8 x 3/4	-	-
-	-	-	-	135	20	20 x 30	3/4	3/4 x 1 1/4	-	-
-	-	-	-	145	40	40 x 60	1 5/8	1 5/8 x 2 3/8	-	-
1 Cable	120	1 Cable	4 3/4	126	-	-	-	-	-	-
3 Cables	60	3 Cables	2 3/8							
1 Cable	140	1 Cable	5 1/2	128	-	-	-	-	-	-
2 Cables	80	2 Cables	3 1/4							
-	-	-	-	120	8	8 x 8	3/8	3/8 x 3/8	-	-
12	30	1/2	1 1/4	140	12	12" x 12	1/2	1/2" x 1/2	10	3/8
10	100	3/8	4	142	20	20 x 30	3/4	3/4 x 1 1/4	20	3/4
20	60	3/4	2 3/8							
20	130	3/4	5 1/4	144	30	30 x 50	1 1/4	1 1/4 x 2	25	1
30	60	1 1/4	2 3/8							
40	100	1 5/8	4	146	40	40 x 70	1 5/8	1 5/8 x 2 3/4	30	1 1/4
1 Cable	120	1 Cable	4 3/4	126	-	-	-	-	-	-
3 Cables	60	3 Cables	2 3/8							
1 Cable	140	1 Cable	5 1/2	128	-	-	-	-	-	-
2 Cables	80	2 Cables	3 1/4							

This is the Repair chart valid at the time of printing.
 Always refer to the Repair chart and safety advice packed With the product!

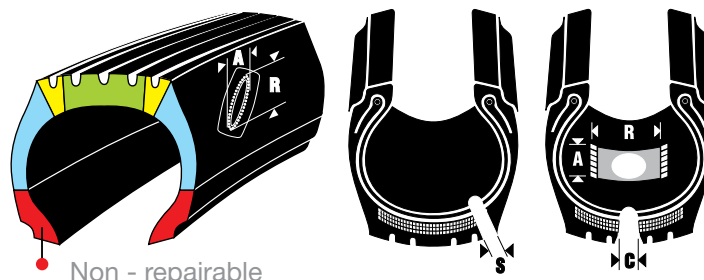



Tire Repair Materials

RAD 100 Series Section Repair Chart

Vmax 30mph					①		RAD No.	②		②		③				
Standard 100 - 90	Series 85 - 80	Series 75 - 70	Series 65 - 60	Series 55 - 45	max A mm	max R mm		max. C Ø mm	max. A x R mm	max. C Ø inch	max. A x R inch	max. S mm	max. S inch			
8.3 - 12.4 180/ - 270/	275/ - 320/	200/ - 360/	320/ - 340/		-	-	-	-	115	12	12" x 12	½	½" x ½	-	-	
					20	20	¾	¾	120	20	20 x 30	¾	¾ x 1¼	10	¾	
					50	70	2	2¾	180	40	40 x 60	1½	1½ x 2¾	25	1	
					70	50	2¾	2	182	60	60 x 75	2½	2½ x 3	45	1¾	
					60	100	2¼	4	184	75	75 x 90	3	3 x 3½	55	2½	
					100	75	4	3								
					60	125	2¾	5								
13.6 - 18.4 12 - 15	335/ - 420/	375/ - 520/	420/ - 540/		-	-	-	-	115	10	10 x 10	¾	¾ x ¾	-	-	
					15	25	⅝	1	120	15	15 x 15	⅝	⅝ x ⅝	10	¾	
					40	60	1½	2¾	180	30	30 x 50	1¼	1¼ x 2	20	¾	
					60	40	2¾	1½	182	60	60 x 70	2½	2½ x 2¾	40	1½	
					60	100	2¾	4	184	80	80 x 100	3¼	3¼ x 4	50	2	
					85	70	3¾	2¾	186	100	100 x 140	4	4 x 5½	75	3	
					75	125	3	5	190	125	125 x 150	5	5 x 6	80	3¼	
					100	75	4	3								
					90	140	3½	5½								
					125	110	5	4¾								
					20.8 - 30.5	460/ -	540/ - 710/	600/ - 800/	700/ - 1050/	10	20	¾	¾	120	10	10 x 10
25	60	1	2¾	180						25	25 x 40	1	1 x 1½	10	¾	
40	100	1½	4	182						40	40 x 60	1½	1½ x 2¾	30	1¼	
60	125	2¾	5	184						70	70 x 90	2¾	2¾ x 3½	40	1½	
85	75	3¾	3	186						85	85 x 120	3¾	3¾ x 4¾	60	2¾	
85	120	3¾	4¾	190						100	100 x 175	4	4 x 6¾	70	2¾	
120	80	4¾	3¼													
90	180	3½	7½													
125	125	5	5													
160	200	6¼	8													
125	250	5	10													

Vmax 25mph					①		RAD No.	②		②		③			
Standard 100 - 90	Series 85 - 80	Series 75 - 70	Series 65 - 60	Series 55 - 45	max A mm	max R mm		max. C Ø mm	max. A x R mm	max. C Ø inch	max. A x R inch	max. S mm	max. S inch		
5.00 - 7.00		150/ - 200/			-	-	-	-	115	6	6 x 6	¼	¼ x ¼	-	-
					10	10	¾	¾	120	10	10 x 10	¾	¾ x ¾	6	¼
					10	50	¾	2	122	10	10 x 20	¾	¾ x ¾	6	¼
					15	30	⅝	1¼							
7.50 - 10.00		225/ - 315/	250/ - 355/		-	-	-	-	115	3	3 x 3	⅛	⅛ x ⅛	-	-
					8	10	¾	¾	120	10	10 x 10	¾	¾ x ¾	6	¼
					8	30	¾	1¼	122	10	10 x 15	¾	¾ x ⅝	6	¼
					18	70	1⅛	2¾	140	18	18 x 30	1⅛	1⅛ x 1¼	10	¾
					15	50	⅝	2	142	25	25 x 35	1	1 x 1¾	12	½
					18	70	1⅛	2¾							
25	50	1	2												

This is the Repair chart valid at the time of printing. Always refer to the Repair chart and safety advice packed With the product!

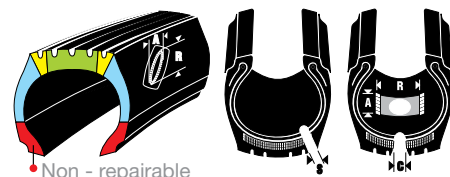



Rema Tire Repair Materials

RAD 100 Series Section Repair Chart / OTR



Series 100	Series 75 - 80	Series 65	max. A mm	max. R mm	max. A inch	max. R inch	RAD No.	max. C Ø mm	max. A x R mm	max. C Ø inch	max. A x R inch	max. S mm	max. S inch		
14.00 - 30.00	15.5 - 33.5	20/ - 50/	20	70	¾	2¾	144	20	20 x 40	¾	¾ x 1½	15	5/8		
			25	150	1	6	146	40	40 x 60	1½	1½ x 2¾	20	¾		
			50	100	2	4	150	50	50 x 80	2	2" x 3¼	35	1¾		
25	250	1	10	152	50	250		2	10	90	90 x 120	3½	3½" x 4¾	55	2½
50	150	2	6		100	150		4	6		156	90	90 x 140	3½	3½" x 5½
16.00 - 40.00	17.5 - 55	25/ - 65/	50	300	2	12	168	100	100 x 150	4		4 x 6	70	2¾	
			100	200	4	8		160	90	90 x 180		3½	3½" x 7½	65	2½
			130	180	5¼	7½	162		100	100 x 220	4	4 x 8½	70	2¾	
140	170	5½	6¾	120	250	4¾			10	145	40	40 x 70	1½	1½ x 2¾	-
27.00 - 40.00	29.5 - 55	45/ - 65/	60	400	2¾	16	155	40	40 x 70		1½	1½ x 2¾	-	-	
33.00 - 40.00	37.25 - 55	55/ - 65/	60	480	2¾	18¾		25	25 x 50		1	1 x 2	-	-	
14.00 - 18.00	15.5 - 20.5	20/ - 35/	-	-	-	-	165	60	60 x 90	2¾	2¾ x 3½	-	-		
21.00 - 30.00	23.5 - 33.5	40/ - 50/	-	-	-	-		40	40 x 70	1½	1½ x 2¾	-	-		
16.00 - 21.00	17.5 - 23.5	25/ - 35/	-	-	-	-		25	25 x 50	1	1 x 2	-	-		
24.00 - 30.00	26.5 - 33.5	40/ - 50/	-	-	-	-	175	80	80 x 110	3¼	3¼ x 4¾	-	-		
33.00 - 40.00	37.25 - 50.5	55/ - 65/	-	-	-	-		60	60 x 90	2¾	2¾ x 3½	-	-		
21.00 - 30.00	23.5 - 33.5	40/ - 50/	-	-	-	-	185+	100	100 x 140	4	4 x 5½	-	-		
27.00 - 40.00	29.5 - 55	45/ - 65/	-	-	-	-		150	150 x 220	6	6 x 8½	-	-		
24.00 -	26.5 -	40/ -	-	-	-	-	185+	300	100 x 140	12	4 x 5½	-	-		
36.00 -	36.5 -	40/ -	-	-	-	-		-	-	-	-	-	-		

This is the Repair chart valid at the time of printing. Always refer to the Repair chart and safety advice packed With the product!

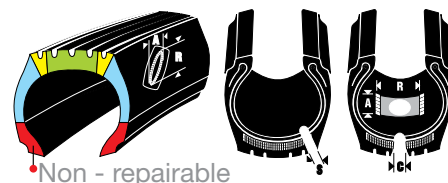



Rema Tire Repair Materials

Bias - Ply Repair Chart

P·N

DIAGONAL



C		PR PLY RATING	- 6	8 - 10	12 - 14	16 - 18
max. mm	max. inch					
25	1"	PN - Nr.	20	20	20	20
50	2"	PN - Nr.	20	20	21	23
75	3"	PN - Nr.	20	23	23	24
125	5"	PN - Nr.	21	24	24	25
175	7"	PN - Nr.	22	25	25	-

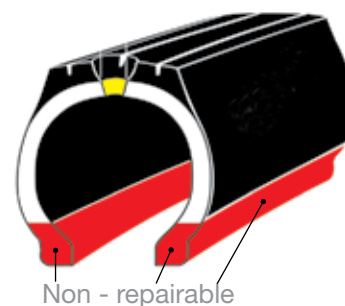

C		PR PLY RATING	- 8	10 - 12	14 - 16	18 - 20	22 - 24
max. mm	max. inch						
25	1"	PN - Nr.	40	41	41	42	42
50	2"	PN - Nr.	40	41	42	42	-
75	3"	PN - Nr.	-	42	42	-	-



C		PR PLY RATING	- 4	6 - 8	10 - 12	14 - 16	18 - 20	22 - 24	- 12	14 - 18	20 - 24
max. mm	max. inch										
10	3/8"	PN - Nr.	3	3	3	3	4	4	3	3	3
15	1/2"	PN - Nr.	3	3	4	4	5	5	3	3	4
25	1"	PN - Nr.	3	4	5	6	6	6	3	4	5
35	13/8"	PN - Nr.	4	4	5	6	7	7	3	4	5
50	2"	PN - Nr.	5	5	6	7	8	8	5	5	6
75	3"	PN - Nr.	-	-	7	7	9	9	6	6	7
100	4"	PN - Nr.	-	-	8	8	9	10	7	7	8
125	5"	PN - Nr.	-	-	-	10	10	-	-	8	8



PN o2 - o10





Bias - Ply Repair Chart/OTR Rema Tire Repair Materials



Tread and Shoulder Injuries, Section Repair

max. mm	C max. inch	PR PLY RATING	10-14	16-20	22-26	28-32	34-38	40-44	46-50	52-58	60-
			15	1/2	PN-Nr.	050	050	050	050	050+	050+
25	1	PN-Nr.	050	050	050	050+	050+	050+	050+	052	052
50	2	PN-Nr.	050	050	050	050+	052	052	052	054	054
75	3	PN-Nr.	050	050+	052	052	052	052+	054	054+	056
100	4	PN-Nr.	052	052	052	052+	054	054+	056/052+	056/052+	058/052+
125	5	PN-Nr.	052	052+	052+	054	054+	056+	056/052+	056+/054	056+/054+
150	6	PN-Nr.	052	054	054	054+	054+	056/052	056/054	056+/054	058/056
175	7	PN-Nr.	052	054	054	054+	056+	056+/052	058+/054	058+/054	058+/056
200	8	PN-Nr.	-	054	056	056+	058+	056+/052	058/056	058+/056	056+
225	9	PN-Nr.	-	-	056	056+	058+	058/054	058+/056	056	056
250	10	PN-Nr.	-	-	056	056+	058/052	058/054	056	056	056+

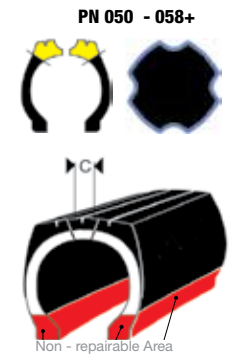

Sidewall Repair

max. mm	C max. inch	PR PLY RATING	10-14	16-20	22-26	28-32	34-38	40-44	46-50	52-58	60-
			15	1/2	PN-Nr.	050	050	050	050	050+	050+
25	1	PN-Nr.	050	050	050	050+	050+	050+	050+	052	052
50	2	PN-Nr.	050	050	050	050+	052	052	052	054	054
75	3	PN-Nr.	050	050+	052	052	052	052+	054	054+	056S
100	4	PN-Nr.	052	052	052	052+	054	054+	056S/056+	056S/052+	056S/052+
125	5	PN-Nr.	052	052+	052+	054	054+	056+	056S/052+	056+/054	056+/054+
150	6	PN-Nr.	052	054	054	054+	054+	056S/052	056+/054	056+/054	058S/056S
175	7	PN-Nr.	052	054	054	054+	056+	056+/052	058S+/054	058S+/054	058S+/056S
200	8	PN-Nr.	-	054	056S	056S+	058S+	056+/052	058S/056S	058S+/056S	056+



Non - penetrating Injury (up to 50%) to tread or shoulder (Reinforcement Repair)

max. mm	C max. inch	PR PLY RATING	10-14	16-20	22-26	28-32	34-38	40-44	46-50	52-58	60-
			50	2	PN-Nr.	050	050	050	050+	052	052
100	4	PN-Nr.	050	050	052	052	052+	052+	054	054+	054+
150	6	PN-Nr.	052	052	054	054	054	054	054+	054+	056+
200	8	PN-Nr.	-	054	054	054	054	056	056	056+	058+
250	10	PN-Nr.	-	-	054	056	056	056	056+	058	058+

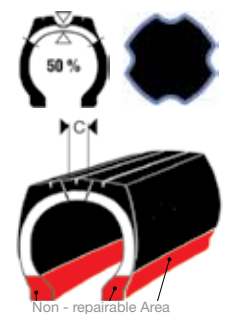

Non - penetrating Injury (up to 50%) to the Sidewall area (Reinforcement Repair)

max. mm	C max. inch	PR PLY RATING	10-14	16-20	22-26	28-32	34-38	40-44	46-50	52-58	60-
			50	2	PN-Nr.	050	050	050	050+	052	052
100	4	PN-Nr.	050	050	052	052	052+	052+	054	054+	054+
150	6	PN-Nr.	052	052	054	054	054	054	054+	054+	056+
200	8	PN-Nr.	-	054	054	054	054	056S	056S	056+	058S+
250	10	PN-Nr.	-	-	054	056S	056S	056S	056+	058S	058S+

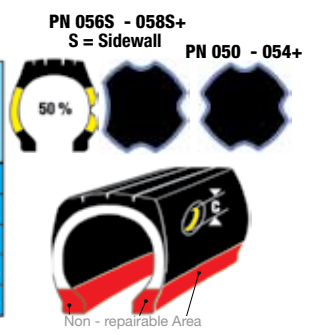



COMBI TIRE REPAIR

A Small Diameter Steel Pilot Wire Is Molded Into The Plugs On These Combi Units. When The Wire Is Pulled Through The Injury, The Plug Fills The Injury And The Patch Seals The Inner liner. Install With KX - 511F Flammable Chemical Cement. Use In Conjunction With CC - 6, CC - 10 Carbide Cutters

Code	Description	W	Qty
KX - 375	Kex Reinforced Patch Plug	1/4" Stem	25 Box
KX - 376	Kex Reinforced Patch Plug	3/8" Stem	25 Box
KX - 381	Kex Non - Reinforced Patch Plug	1/4" Stem	25 Box
KX - 382	Kex Non - Reinforced Patch Plug	3/8" Stem	25 Box
KX - 386	Kex Minicombi 1/8	1/8" Stem	25 Box
KX - 387	Kex Combi With Pilot Wire	1/4" Stem	25 Box
KX - 388	Kex Combi With Pilot Wire	3/8" Stem	25 Box
KX - 378	Kex Stem With Pilot Wire	1/4" Stem	20 Box
KX - 379	Kex Stem With Pilot Wire	3/8" Stem	20 Box



RADIAL REINFORCED REPAIR

MX Centre Over The Injury Radial Repair Units Are Designed For Use In Crown, Shoulder (Passenger And Truck Tire), Or Sidewall (Truck Tire) Repair . Install With KX - 511F Flammable Chemical Cement.

Code	Description	W	L	Qty
KX - MX10	KEX Radial Reinforced Repair	2"	3"	20 Box
KX - MX12	KEX Radial Reinforced Repair	3"	4"	10 Box
KX - MX14	KEX Radial Reinforced Repair	3"	4 - 3/4"	10 Box
KX - MX20	KEX Radial Reinforced Repair	3"	5"	10 Box
KX - MX22	KEX Radial Reinforced Repair	3"	6"	10 Box
KX - MX24	KEX Radial Reinforced Repair	3"	8"	10 Box
KX - MX40	KEX Radial Reinforced Repair	4"	8"	10 Box
KX - MX42	KEX Radial Reinforced Repair	5"	10"	10 Box
KX - MX44	KEX Radial Reinforced Repair	5"	13"	10 Box



BIAS REPAIR

Tire Cord Reinforced Bias Ply Patches For Repair In Passenger, Truck And Agricultural Bias Repairs Ply Tires. Install With KX - 511F Flammable Chemical Cement.

Code	Description	W	L	Ply	Qty
KX - 470	KEX Bias Repair	3"	3"	2 ply	20 Box
KX - 471	KEX Bias Repair	4"	4"	2 ply	10 Box
KX - 472	KEX Bias Repair	5"	5"	3 ply	10 Box
KX - 473	KEX Bias Repair	7"	7"	4 ply	10 Box
KX - 474	KEX Bias Repair	8"	8"	6 ply	10 Box



UNIVERSAL REPAIR

KEX Rubber Reinforced Universal Ply Patches For Repair In Passenger, Truck And Agricultural Universal Repairs Ply Tires. Install With KX - 511F Flammable Chemical Cement.

Code	Description	W	L	Qty
KX - UP - 45	KEX Universal Repair 45	1"	3/4"	30 Box
KX - UP - 45P	KEX Universal Repair 45 Pail	1"	3/4"	300 Box
KX - UP - 55	KEX Universal Repair 55	2"	1/8"	30 Box
KX - UP - 55P	KEX Universal Repair 55 Pail	2"	1/8"	200 Box





RADIAL REPAIR

These Universal Tire Repair Patches Are Reinforced With Tire Cord For Added Strength. For Non - Directional Installation. Recommended For Puncture Repair In The Tread Area Of The Tires. Use On Both Bias And Radial Tires. Install With KX - 511F Flammable Chemical Cement.

Code	Description	W	L	Qty
KX - 5101	KEX Radial Reinforced Repair 5101	1"	1/4"	120
KX - 5102	KEX Radial Reinforced Repair 5102	2"	1/4"	100
KX - 5103	KEX Radial Reinforced Repair 5103	3"	1/8"	50



KX - 5101

KX - 5102

KX - 5103

VULCANIZING CHEMICALS

KEX Super Fast Dry Cement

Code	Description	Size
KX - 511F	KEX Super Fast Dry Cement	8 oz



KX - 511F

PRE - BUFFING CLEANER

Use Buffing Solution In Conjunction With Scraping Tool To Dissolve And Remove Lubricants And Contaminents From The Inner liner Before Buffing. (Flammable).

Code	Description	Size
KX - 490F	KEX Pre - Buffing Cleaner	32 oz
KX - 491F	KEX Pre - Buffing Aerosol	16 oz



KX - 490F



KX - 491F

REPAIR FINISHING

Designed For Use Around The Edges Of Repair Units, Over Buffing Areas And On Porous Innerliners.

Code	Description	Size
KX - 508F	KEX Inner liner Sealer Flammable	16 oz



KX - 508F

EMERGENCY REPAIRS

Deluxe Box Contains: One Jar Of Lubricant, One Knife And Fifty Each 361 Fat Brown String Repair 4".

Code	Description	Size
KX - 311	KEX Emergency Vulcanizing Strip	2 - 1/2" X 1/4"
KX - 331	KEX Emergency Magicur	2 - 1/2" X 1/4"
KX - 361	KEX Emergency Fat Brown String	4"
KX - 362	KEX Emergency Fat Brown String	8"
KX - 363	KEX Emergency Fibre Seal Insert	3 - 3/4"
KX - 365	KEX Emergency Deluxe Fat Brown String	4"
KX - 370	KEX Emergency Narrow Black String	7"



KX - 365

Nail Hole Repair Chart - Crown Area Only

Tire Type	Injury Size	Carbide Cutter	1 - Piece Repair (Injury Angle < 25 degrees)			2 - Piece Repair (Injury Angle > 25 degrees)			
			Combi With Pilot Wire	Patch - N - Plug Non - Reinforced	Patch - N - Plug Reinforced	Stem Unit/W Pilot Wire	Universal Patch	Radial Patch	Universal Cord Reinforced
Passenger	1/4" "/6 mm	CC - 6	KX - 387	KX - 381	KX - 375	KX - 378	KX - UP - 45	KX - MX10	KX - 5101
Light Truck	1/4" "/6 mm	CC - 6	KX - 387	KX - 381	KX - 375	KX - 378	KX - UP - 55	KX - MX12	KX - 5102
Heavy Duty Truck	1/4" "/6 mm	CC - 6	KX - 387	KX - 381	KX - 375	KX - 378	NA	KX - MX14	KX - 5102
	3/8" /10 mm	CC - 10	KX - 388	KX - 382	KX - 376	KX - 379	NA	KX - MX20	KX - 5103

Radial Tire Section Repair Chart

W = Width L = Length C = Max. Dia.	1 = Sidewall 2 = Tread 3 = Shoulder		
Heavy Truck		Sidewall Injury	Crown Injury
Injury Inches		Injury Inches	
8.25 - 10.00 9R - 11R 235/ - 285/	11.00 - 14.00 12R - 15R 295/ - 365/	W	L C
MX 20	MX 20	1 Cable	1 - 1/2" (37 mm) 3/8" (10 mm)
MX 22	MX 22	1 Cable	3 - 1/8" (78 mm)
MX 24	MX 24	1 Cable	4 - 3/4" (120 mm)
MX 20	MX 22	2 Cables	3/4" (20 mm)
MX 22	MX 24	2 Cables	1 - 1/2" (37 mm)
MX 24	MX 40	2 Cables	2 - 3/4" (70 mm)
MX 24	MX 40	3/8" (10 mm)	1" (25 mm)
MX 24	MX 40	3/8" (10 mm)	1 - 1/2" (37 mm)
MX 24	MX 42	3/8" (10 mm)	2 - 3/8" (60 mm)
MX 44	MX 44	3/8" (10 mm)	5 - 1/8" (128 mm)
MX 40	MX 40	1/2" (12 mm)	1 - 1/2" (37 mm) 1/2" (12 mm)
MX 40	MX 42	1/2" (12 mm)	2 - 3/4" (70 mm)
MX 42	MX 42	1/2" (12 mm)	3 - 3/4" (95 mm)
MX 44	MX 44	1/2" (12 mm)	5 - 1/8" (128 mm)
MX 40	MX 40	3/4" (20 mm)	1" (25 mm) 3/4" (20 mm)
MX 40	MX 42	3/4" (20 mm)	2 - 1/2" (62 mm)
MX 42	MX 42	3/4" (20 mm)	4 - 3/8" (110 mm)
MX 44	MX 44	3/4" (20 mm)	5 - 1/8" (128 mm)
MX 42	MX 44	1" (25 mm)	2" (50 mm) 1" (25 mm)
MX 42	MX 44	1" (25 mm)	3 - 1/8" (78 mm)
MX 44	MX 44	1" (25 mm)	4" (100 mm)
MX 42	MX 44	1 - 1/4" (31 mm)	2" (50 mm) 1 - 1/4" (31 mm)
MX 44	MX 44	1 - 1/4" (31 mm)	3 - 1/8" (78 mm)
MX 44		1 - 1/4" (31 mm)	4" (100 mm)
MX 44	MX 44	1 - 1/2" (37 mm)	2" (50 mm) 1 - 1/2" (37 mm)
MX 44		1 - 1/2" (37 mm)	3 - 1/8" (78 mm)

Bias Ply Tire Section Repair Chart

Inches	mm	Ply Rating							
		4	6	8	10	12	14	16	18
3/8"	(10 mm)	470	470	470	470	470	470	471	472
1/2"	(12 mm)	470	470	470	470	471	472	472	473
3/4"	(20 mm)	470	470	470	470	471	472	473	473
1"	(25 mm)	470	470	471	472	472	473	473	474
1 - 1/2"	(37 mm)	471	471	471	472	473	474	474	474
2"	(50 mm)	473	473	473	474	474	474	474	
2 - 1/2"	(62 mm)	474	474	474	474	474			

Bias Tire Patch Selection

- Only after the Injury has been properly skived can the correct patch be selected.
- When measuring the Injury, always measure the longest damage of the top damaged ply.
- Note the ply rating of the Tire. (This can be found embossed into the Sidewall of the Tire).
- Find the Injury size on the Application Chart, read across the chart to find the correct patch based on the Tire ply rating.

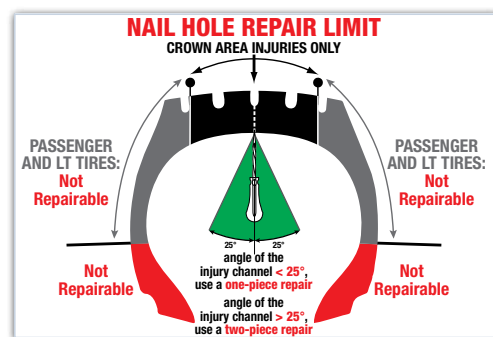

Radial Tire Patch Selection

- Only after the Injury has been properly skived/prepared can the correct patch be selected.
- Measuring the Injury:
 - Sidewall Injuries: Measure the length (L) and Width (W) of the Injury.
 - Tread/Crown Injuries:
 - If the skived/dressed Injury is round, measure only the maximum Diameter (C) of the Injury at the body ply.
 - If the skived/dressed Injury is oval or oblong shaped, measure both the length (L) and the Width (W) of the Injury at the body ply.
 - If the maximum measurement of (C) is greater the (L) and (W) measurement, select the larger of the patches.
- Using the Tire Size column on the Application Charts, find the Injury area column – Sidewall, Tread/Crown or Shoulder – and go down the corresponding column until you match the measured size of the Injury to the correct patch.



Tire Repair Tools





CARBIDE CUTTERS

Designed To Prepare Tire Injuries To Accept The Corresponding Combi Or Combi - Stem Unit By Removing The Damage And Rounding The Hole To Prevent It From Growing After It Has Been Repaired

Code	Description	Size
PCC - 1	Carbide Cutter	1/16"
PCC - 2	Carbide Cutter	1/8"
PCC - 2P	Carbide Cutter	1/8"
2 - 270P	Carbide Cutter	1/8"
2 - 270	Carbide Cutter	1/8"
CC - 4.5	Carbide Cutter	3/16"
PCC - 3	Carbide Cutter	1/4"
PCC - 3P	Carbide Cutter	1/4"
CC - 6	Carbide Cutter	1/4"
CC - 8	Carbide Cutter	5/16"
CC - 10	Carbide Cutter	3/8"
PCC - 4	Carbide Cutter	3/8"
PCC - 5	Carbide Cutter	1/2"



SCREW DRIVER AND T - HANDLE TOOLS

For Preparing And Inserting Vulcanizing Inserts.

Code	Description
900	7" Insertion Tool
901	9" Insertion Tool
905	12" Insertion Tool
KX - 928	Metal Passenger T - Handle With Needle
KX - 931	T - Handle - Replacement Needle For KX - 928
903	T - Handle 3/16" Cutter - Passenger
903RC	Replacement 3/16" Cutter
2 - 903IT	Chrome Passenger T - Handle With Needle

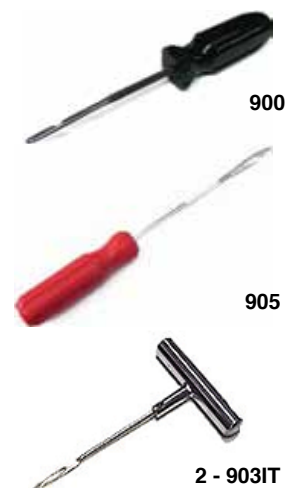

PISTOL GRIP TOOLS

Pistol Grip Tools For Inserting Premafills.

Code	Description
911	Allen Key - Insert Tool
925	Premafill Insert Tool - Passenger
925AS	Replacement Allen Screw - Insert Tool
926	Passenger Slit Eye Replacement Needle
927	Truck Slit Eye Replacement Needle
2 - 911	Allen Key Insert Tool
2 - 925	Premafill Insert Tool - Passenger
2 - 925AS	Replacement Allen Screw - Insert Tool
2 - 925T	Premafill Insert Tool - Truck
2 - 925RT	Pistol Grip Probe/Rasp Tool
2 - 925E	Permafll Insert Tool - OTR
2 - 926	Passenger Slit Eye Replacement Needle
2 - 927	Truck Slit Eye Replacement Needle
2 - 928	OTR Replacement Needle
T116	Die Cast T - Handle Insert Tool
T116 - N	Replacement Needle For T116





TIRE REPAIR HAND TOOLS

Code	Description
914	Spiral Cement Drill Tool
916	OTR Giant Spiral Cement Tool
2 - 915	Spiral Cement Tool
2 - 910	Fluted Probing And Cement Tool
907	1 - R Hand Rasp 6 - 3/4" Blade
908	2 - R Hand Rasp 9 - 1/4" Blade
2 - 903PT	Chrome Passenger T - Handle Probe
T154	Barbed Rasp With Screwdriver Handle
HD351	Heavy Duty AWL - 4 - 1/2" Blade
69 - 122	Stanley 6 - 1/4" Scratch AWL
919	All Purpose AWL
918	Duck Bill AWL
2 - 919	All Purpose AWL
2 - PPL	Puncture Push Probe - Large
2 - PPS	Puncture Push Probe - Small II



Clean Surface Contamination From The Inner liner Before Buffing To Ensure Maximum Adhesion. Use With Liquid Rubber Buffing Solution For Best Results.

Code	Description
933	Rubber Scraper
2 - 933	Rubber Scraper



Economical Brass Bristle Brush. Great For Removing Buffing Dust In Tire Repair Application.

Code	Description
974	6014 Hand Brush - Brass Bristle



STITCHERS

Serrated, Smooth And Porcupine Stitchers Used For A Variety Of Tire Repair Purposes.

Code	Description
MR02080	Smooth Roller - 2" x 3"
MR02890	Stitcher 2" X 1/16"
MR02910	Stitcher 2" X 1/4"
MR02040	Smooth Roller - 2" x 2"
MR02110	Smooth Roller - 2" x 6"
MR02860	Stitcher 1 - 1/2" x 1/8"
MR02980	Stitcher 1 - 3/4" x 1/4"
MR10910	2 - 9/16" Extended Corrugated Stitcher - Goose Neck
MR10880	4 - 3/16" Extended Corrugated Stitcher - Goose Neck
MR03150	2 - 1/2" x 1/4" Corrugated Stitcher
MR02990	2" x 3/8" Corrugated Stitcher
K - 55D	2" x 2" Porcupine Stitcher
K - 21	Stitcher 1 - 1/2" x 1/32" - Serrated
K - 56	Stitcher 2" x 1/4" - Serrated
935	Economy Stitcher
936	Wood Handle Stitcher
2 - 936	1/8" Stitcher Plastic Handle
2 - 938	1/16" Stitcher Wooden Handle
2 - 939	2" x 1/4" Stitcher - Wooden Handle



MR02040



MR02860



MR02980



T2000

PLIERS

Code	Description
T2000	PTA 6" Slip Joint Plier
T2005	PTA 8" Slip Joint Plier
T2035	PTA 7 - 1/2" Diagonal Cutter
10CR - 3	Vice Grip Curve Jaw Locking Plier



10CR - 3



T2005



T2035

VACUUMS AND ACCESSORIES

For Removing Debris From Buffed Tire Innerliners.

Code	Description
S999	Air Powered Vacuum
S999 - Bag	Replacement Air Vacuum Bag
798	Air Power Vacuum With Bag And Hose



S999 - Bag

SHOP LIGHTS

Industrial Shop Lights For Tire Repairs.

Code	Description
15 - HDL2508	Work Light With 25 - Foot Retractable Cord
HR - ECL40	40 - Foot Stubby Lite Cord In Reel
S1055N	Repair Light With 25 - Foot Power Cord



15 - HDL2508





BUFFERS, DRILLS AND ACCESSORIES

Rubberhog Flared Contour Wheel Mini - Cup - New Style.

Code	Description
RH130	2" Flared Contour Wheel SSG 60
RH130 - 170	2" Flared Contour Wheel SSG 170
RH130 - 230	2" Flared Contour Wheel SSG 230



RH130

Heavy Duty Air Low - Speed Tire Buffer. Designed For Conveniences. The Many Features Of The 327LS Make It The Ideal Tool For Every Tire Shop. The Quick Change Chuck, Built - In Regulator And Lever - Style Throttle Make Patchwork, Roughing Areas For Recapping And Cleaning Tire Molding A Breeze. Features Lever - Style Tease Trigger With Lock - Off For Easy Operation And Protection Against Accidental Start - Up. Quick Change Chuck For Easy Buffering Wheel Change. Piped - Away Exhaust (Included) Directs Air Away From Work Area And Operator. Convenient Hanger Keeps Tool Within Easy Reach.

Code	Description
CP - 873	Low Speed Air Buffer - 2500RPM
CP - 873K	2500 RPM Low Speed Buffer With - X - Hose
IR - 327LS	Low Speed - Heavy Duty Tire Buffer



IR - 327LS



CP - 873

Ideal Tool For All Types Of Maintenance Work. Features. 3/8" (10 mm) Pistol Drill. Powerful Energy - Efficient Motor Resists Stalls. Handle Exhaust.

Code	Description
CP - 785	3/8" General Air Drill Forward Only
CP - 785H	1/2" General Air Drill Forward Only



CP - 873K

Reversible, High Power And Durable Drills For Industrial Maintenance, Great For Operators' Productivity, Durability And Comfort. Great Tool For Small Hole Drilling And Aluminum Work. Features. 3/8" (10 mm) Reversible Pistol Drill. Powerful With 0.5 Horsepower (370 Watts) Motor. Teasing Throttle And High - Speed Precision Drilling At 4200 RPM. Industrial Quality Jacobs Chuck. Durable GearBox. Ergonomic Grip.

Code	Description
CP - 789R - 42	3/8" Heavy Duty Reversible Air Drill - 4200RPM

Heavy Duty Air High - Speed Tire Buffer . With A Free Speed Up To 22,000 RPM And Powerful 0.50 Horsepower Motor, These Buffers Will Make Quick Work Of Patchwork And Roughing Up Low Areas For Recapping, Tire Scuffing And Cleaning Tire Moldings. Features Lever Throttle For Easy Operation. Rear Exhaust Keeps Air Away From You And Your Work

Code	Description
IR - 327	IR High - Speed Air Buffer - 22,000 RPM
CP - 871	Hi - Speed Air Buffer - 22000 RPM



CP - 785H



IR - 327



CP - 871



BUFFERS, DRILLS AND ACCESSORIES

Quick Change Chucks

Code	Description
QRF - 14	1/2" - 20" Quick Change Chuck - 7/16" HEX
SLP - 9165	3/8" - 24" Quick Change Chuck



QRF - 14

TIRE SPREADER

Manual And Air Operated Tire Spreaders.

Code	Description
2 - 981	Passenger Tire Spreader
981 - S	Metal Stand For 2 - 981 - 40"
50 - RB	Rep Boy Tire Spreader Assembly
AME - 73080	Floor Mount Tire Spreader With Rollers
AME - 73100	Air Operated Tire Spreader
AME - 73200	Automatic Tire Spreader



981 - S

Manual Speed Tire Spreader With Lock Pin. Spread Capability 4" To 6" (10.2 Cm. To 15.2 Cm.)

Code	Description
T51	Manual Passenger LT Tire Spreader With Lock Pin
5500 - BRANICK	Passenger / Truck Adjustable Height Tire Spreader



2 - 981

The Model LR - EF Is Typically Used For Both Passenger And Truck Tires. This Spreader Is Air Powered And Has An Easy To Use Tire Lift. The High - Impact Industrial Light Is Mounted On A Flexible Arm Making It Easier For Inspection And Repair. Made In The U.S.A.

Code	Description
LR - EF	Branick Tire Spreader With Lift



LR - EF



50 - RB



TIRE SPREADER AND DUNK TANKS

The Model LR Is Typically Used For Both Passenger And Truck Tires. It Does Not Come With A Tire Lift, But It Is Air Powered (See LR - EF For Tire Lift). It Is An Affordable And Simple Solution For Truck Tires. The High - Impact Industrial Light Is Mounted On A Flexible Arm Making It Easier For Inspection And Repair. Made In The U.S.A.

Code	Description
LR	Branick Tire Spreader Only



5120

The Model 5120 Is Typically Used For Both Passenger And Light Truck Tires When You Need A Little More From A Spreader. It Is Air Powered, Easy On The Operator And Your Bottom Line. It Comes With A Convenient Tool Tray That Can Be Mounted On Either Side Of The Spreader. The Stabilizer 4 - Point Base Can Be Bolted To The Floor And There's A Foot Control Valve For Spreading The Tire, Which Also Gives You A Stabilized Work Surface.

Code	Description
5120	Inverting Tire Spreader (Air)

The Model TC630 Is Manual Truck Tire Spreader

Code	Description
TC630	Truck Tire Spreader



TC630

Simple To Use And Heavy Duty Construction Makes Rema Tip Top's Portable OTR/EM Tire Spreader A Must For OTR/EM Tire Replacing. Available In Mechanical And Hydraulic.

Code	Description
5199222	OTR Mechanical Tire Spreader
5199181	OTR Hydraulic 5.5 - Ton Tire Spreader



5199181

DUNK TANKS

Inner Tank Diameter 33" x 33" x 19". Outer Tank Diameter 36" X 36" X 28". Handles Passenger And Light Truck Tires. Protected Plunger Will Not Mar Rims. Use Approximately 45 Gallons (3/4" Full). Includes Floor Dra 3/8" Hex Bolts And Lock Nuts In Assembly. Has 9/16" Hex Heads.

Code	Description
333	Tire Leak Finder Complete Assembly



333

Tubeless Passenger Tire Test Tank. Made Of Durable Polyethylene To Withstand Rugged Use. Inside Dimensions 31" x 10 - 1/4" x 12 - 1/2" . Will Not Dent.

Code	Description
HPN85T	Passenger Tubeless Tire Test Tank 31"x10 - 1/4" x 12 1/2"

Tubeless Light Truck Tire Test Tank. Made Of Durable Polyethylene To Withstand Rugged Use. Inside Dimensions 35" x 15 - 1/4" x 17" Will Not Dent.

Code	Description
HPN95T	Light Truck Tubeless Tire Test Tank 35" x 15 - 1/4" x 17"



HPN85T



HPN95T



DUNK TANKS

This Complete System Features A Polyethylene Tub Built Into A Steel Frame. The Air - Assisted Arm Holds The Tire Down. Casters Optional. 24" Depth

Code	Description
55TG	Truck Tire Leak Tester - Air Operated - 55" Diameter
39ED	Passenger Tire Leak Tester - Air Operated - 39" Diameter

Tank Powder Neutralizes Impurities In Water To Fight Algicides. It Also Illuminates The Water To Help Isolate The Leak. Used Heavily In The Radiator Industry. Canadian Made.

Code	Description
56 - 1	Tank Powder 1 Bag 500 Grams



55TG



39ED



56 - 1

B&J Rocket America, Inc.



Insist on the Original!

Chosen by Professionals.

Your single source for quality buffing blades and carbides.





Tire Pressure Monitoring Systems





EZ - SENSORS

Schrader EZ - Sensor. Programable Blank Sensor Complete With Rubber Snap - In Valve.

Code	Description
33000	Schrader EZ - Sensor 315 MHz
33000B	Schrader EZ - Sensor 315 MHz. Bag Of 12
33000M	Schrader EZ - Sensor 315 MHz. Box Of 210
33100	Schrader EZ - Sensor 433 MHz
33100B	Schrader EZ - Sensor 433 MHz. Bag Of 12
33100M	Schrader EZ - Sensor 433 MHz. Box Of 210
33200	Schrader EZ - Sensor 433 MHz. With Wal Technology
33200B	Schrader EZ - Sensor 433 MHz. With WAL Technology Bag Of 12
33200M	Schrader EZ - Sensor 433 MHz. With WAL Technology Bag Of 210
20018	Replacement Rubber Snap - In Valve - Ford, GM And EZ Sensor
34000	Aluminum Replacement Valve For Any Rubber Snap - In Valve



33000



7001 - R

REDI - SENSORS

Dill Redi - Sensor. A Multi - Application TPMS Sensor. No Scan Tool Required For Programming

Code	Description
7001	Aluminum Stem Redi - Sensor 315 MHz
7001 - R	Rubber Stem Redi - Sensor 315 MHz
7002	Aluminum Stem Redi - Sensor - Asian Makes
7002 - R	Rubber Stem Redi - Sensor - Asian Makes
7003	Aluminum Stem Redi - Sensor 315 MHz
7004	Aluminum Stem Redi - Sensor 433 MHz
7004 - R	Rubber Stem Redi - Sensor 433 MHz
1305	Redi - Sensor Multi - Pack Contains 6 x 7001, 6 x 7002 and 4 x 7004
1305 - R	Rubber Redi - Sensor Multi Pack - 16 - Pack
1215T	TPMS Kit of 12 Redi - Sensors and 128 Service Kits.



7004

OE REPLACEMENT SENSORS

Schrader OE Replacement TPMS Sensors

Code	Description	Code	Description
20028	TPMS Sensor - Chrysler	20315	TPMS Sensor - Ford With Snap - In Valve
20034	TPMS Sensor - Mitsubishi	20398	TPMS Sensor - Dodge Magnum/Charger/300
20064	TPMS Sensor - Nissan	28078	TPMS Sensor - Saab
20069	TPMS Sensor - Nissan	28096	TPMS Sensor - Mitsubishi Lancer And Outlander
20087	TPMS Sensor - Suzuki	28203	TPMS Sensor - Subaru
20098	TPMS Sensor - Acura/Honda	28204	TPMS Sensor - Nissan
20107	TPMS Sensor - GM Large Trucks	28206	TPMS Sensor - GM With Snap - In Valve
20115	TPMS Sensor - GM Large Trucks	28214	TPMS Sensor - Mercedes
20116	TPMS Sensor - GM Small Trucks	28291	TPMS Sensor - Chrysler
20117	TPMS Sensor - Cadillac/Corvette	28308	TPMS Sensor - Chrysler/Dodge/Jeep
20131	TPMS Sensor - Hummer	28434	TPMS Sensor - Chrysler/Dodge/Jeep
20135	TPMS Sensor - Ford Large Truck	28461	TPMS Sensor - Dodge Ram
20153	TPMS Sensor - GM With Snap - In Valve	28981	TPMS Sensor - Acura/Honda
20158	TPMS Sensor - Chevy	28982	TPMS Sensor - Honda
20161	TPMS Sensor - Nissan	28983	TPMS Sensor - Hyundai



20398

Simple and Accurate

REDI-Sensor™



REDI-Sensor now provides over 90% coverage.
 (7001-HP, 7001HPR, 7002, **7003 NEW**, and 7004)
REDI-Sensor is designed and validated to OEM Specifications

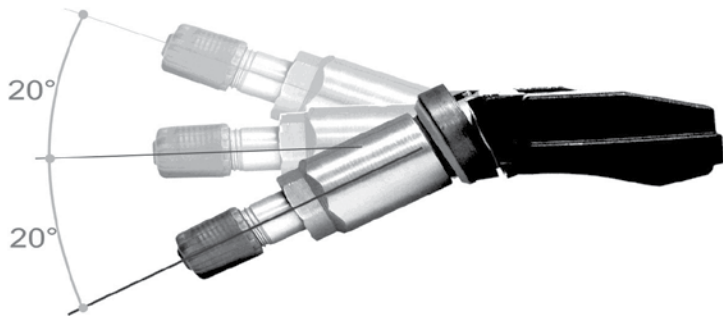

40 degree adjustable angle — fits most wheels!
 “REDI-Sensors are manufactured on OEM equipment”

The NEW 7003 REDI-Sensor covers many popular OEM sensors:



- 1053
- 1054
- 1216
- 1218
- 1041
- 28203
- 20107
- 20131
- 20081
- 20156



For TPMS troubleshooting,
 call Dill at 800-815-3455 option 3
www.dillvalves.com



**OE REPLACEMENT SENSORS***Dill OE Replacement Sensors*

Code	Description	Code	Description
1027	TPMS Sensor - BMW	1218	TPMS Sensor - Toyota
1028	TPMS Sensor - Hyundai/Kia	5105	Ford Band ed Sensor Kit. Comes With Cradle And Band
1042	TPMS Sensor - Dodge Sprinter	5105 - HP	Ford High - Pressure Band ed Sensor Kit With Cradle And Band
1043	TPMS Sensor - Chrysler/Dodge 433 MHz	5512	TPMS Sensor - Honda 315 MHz
1045	TPMS Sensor - Land Rover	5513	TPMS Sensor - Honda 315 MHz
1048	TPMS Ford Band ed Sensor	5556	TPMS Sensor - Nissan 433 MHz
1048 - HP	TPMS Ford High - Pressure Band ed Sensor	5775	TPMS Sensor - Dodge Dart 2013
1051	TPMS Sensor - Chrysler/Dodge/Jeep	9001	TPMS Sensor - Audi/Mercedes
1052	TPMS Sensor - Chrysler/Dodge/Jeep	9002	TPMS Sensor - BMW 3/5/7 Series
1053	TPMS Sensor - Volkswagen	9003	TPMS Sensor - BMW X5/Land Rover
1055	TPMS Sensor - Land Rover/Jaguar	9004	TPMS Sensor - Mercedes S - Class
1056	TPMS Sensor - Mazda	9005	TPMS Sensor - Cayenne/Touareg
1068	TPMS Sensor - Hyundai/Kia	9007	TPMS Sensor - Audi
1204A	TPMS Sensor - Toyota	9008	TPMS Sensor - Porsche 911
1206A	TPMS Sensor - Toyota/Kia/Hyundai	9011	TPMS Sensor - Audi/Volkswagen
1208	TPMS Sensor - Honda/Accord/CRV	9012	TPMS Sensor - BMW
1209	TPMS Sensor - Honda Pilot/ Acura	9013	TPMS Sensor - Volkswagen
1214	TPMS Sensor - Acura	9017	TPMS Sensor - BMW
1216	TPMS Sensor - Nissan	9398	TPMS Sensor - Dodge Magnum/Charger/300
6815	Dodge 1500 2014 TRW Sensor	5555	TPMS Sensor - Nissan 40700
2112	TPMS Sensor - Tesla Car	VS - 1010	Rubber Replacement Stem - Hyundai Santa Fe
5557	TPMS Sensor - Nissan 40700		



1042

REPLACEMENT SERVICE KITS AND STEMS*Dill Replacement Service Kits And Stems*

Code	Description	Code	Description
1092	Aluminum Stem - 43 mm - Clear	1090K	TPMS Service Kit
1093	Aluminum Stem - 48 mm - Green	1098K	TPMS Service Kit
1094	Aluminum Stem - 49 mm - Black	1110K	TPMS Service Kit
1095	Aluminum Stem - 51 mm - Orange	1120K	TPMS Service Kit
1096	Aluminum Stem - 48 mm	2000K	TPMS Service Kit
1097	Aluminum Stem - 58 mm	2020K	TPMS Service Kit
1099	BMW Assembled Valve Stem	7000K	Redi - Sensor Service Pack
1030K	TPMS Service Kit	7020K	Redi - Sensor Service Kit
1031K	TPMS Service Kit	VS - 70	Redi - Sensor Replacement Stem
1040K	TPMS Service Kit	VS - 70B	Redi - Sensor Black Replacement Stem
1050K	TPMS Service Kit	VS - 70S	Redi - Sensor Replacement Stem With HEX Nut And Washer
1060K	TPMS Service Kit	VS - 80	Redi - Sensor - Clip And Snap - In Valve
1070K	TPMS Service Kit	VS - 90	Replacement Valve Stem For 5775 Dodge Dart Sensor
1080K	TPMS Service Kit	VS - 919	GM TPMS Snap - In Valve For 0.625" Rim Hole - Chrome
1100K	TPMS Service Kit	VS - 925A	GM TPMS Snap - In Aluminum Stem
1130K	TPMS Service Kit	VS - 925B	GM Replacement Valve With Black Nut/Cap
2010K	TPMS Service Kit	VS - 925C	TPMS Chrome Valve Stem
2030K	TPMS Service Kit	VS - 930	TPMS Rubber Snap - In Valve
2040K	TPMS Service Kit		



1060K

Dill Service Kit And Stem Assortments

Code	Description
5112	TPMS Service Kit Empty Bin
7100	TPMS Accessory Kit Complete With 76 Kits, Caps And Cores
7300	TPMS Replacement Stem Assortment Kit
9066K	Sch 20020 Stem W/ 2030K Service Kit
VS - 965	Aluminum TPMS Replacement Stem - Hyundai/Kia
2045K	TPMS - Honda/Acura Service Kit



7100

**REPLACEMENT SERVICE KITS AND STEMS***Schrader Replacement Service Kits And Stems*

Code	Description
20006	TPMS Service Kit - Hummer
20013	TPMS Service Kit - Dodge/Chrysler/Jeep
20017	TPMS Service Kit - Volkswagen
20018	Replacement Rubber Snap - In Valve - Ford, GM AND EZ - Sensor
20019	TPMS Service Kit - Honda
20020	Schrader TPMS Service Kit - Replacement Stem
20021	TPMS Service Kit
20030	TPMS Service Kit
20032	TPMS Service Kit
20041	Aluminum Stem Grommet Seat
34000	Aluminum Replacement Valve For Any Rubber Snap - In Valve



20032



20018

Assortment Starter Kit

Code	Description
20597	TPMS Accessory Kit With 96 Service Kits
20598	TPMS Accessory Kit With 72 Service Kits, Caps And Cores
20190	TPMS Cabinet. Includes Most Popular Sensors, Service Kits, Caps And Cores

TPMS SCAN TOOLS

Code	Description
WRT200	TPMS Activation Tool With Bluetooth
WRT300SD	Wheelrite 300SD TPMS Scan Tool
WRT300POBD	OBD Upgrade Kit For WRT300SD
WRT300PSDC	WRT300SD TPMS Tool With OBD Kit Included
WRT400NAT	WRT400SD Scan Tool Kit With Mechanical Tool Kit
WRT400SD	TPMS Scan Tool With OBD Connection
WRT500	Premier TPMS Scan Tool With Bluetooth
WRTPAD1	Wheelrite TPMS Pad For Programing EZ - Sensors
AT - TS55	ATEQ VT55 Scan Tool With OBD



WRT400NAT

SOFTWARE UPDATE CERTIFICATES*Bartec Scan Tool Update Certificates. Keep Your Tool Current And Don't Miss Any New Sensor Updates By Applying These Certificates To Your Tool Account.*

Code	Description
WRT400SUL1	WRT400SD 1 Year Update Certificate
WRT400SUL2	WRT400SD 2 Year Update Certificate
WRT400SUL3	WRT400SD 3 Year Update Certificate
WRTPADSUL1	TPMS Pad 1 Year Update - Multiple Tool User
WRTPADSUL2	TPMS Pad 1 Year Update - Single Registered Tool Users
WRT500SUL1	WRT500 1 Year Update Certificate
WRT500SUL2	WRT500 2 Year Update Certificate
WRT500SUL3	WRT500 3 Year Update Certificate



WRT400SUL3



There is a reason we lead the TPMS Aftermarket...



...because we give you proven OE quality in **BOTH** our OE and Aftermarket sensors.



- ▶ **Schrader patented rubber snap-in stem**
- ▶ **Includes new OE WAL sensor technology**
- ▶ **90% coverage with only 2 part numbers**
- ▶ **Wireless programming and re-writable**



Make the "EZ" choice.

Ask your Prema Distributor about EZ-sensor!



www.SchraderInternational.com



SCAN TOOL PARTS AND ACCESSORIES

Code	Description
WRTRST50	Bartec - Toyota Reset Tool
WRTEZS - STK10	WRT400SD And EZ - Sensor Training Kit
WRTEZS - STK35	WRT400SD And EZ - Sensor Programing Fixture
WRT - MAGNET	WRT300 - Magnet Only
WRT400CAB	WRT400 Tool To OBD Cable
WRT400POBDC	WRT400PLUS - OBD Cable/Connector
WRT4001PC	1 Piece Cable/Connector For Older WRT400 Tools
21370	Schrader Nissan Reset Tool
WRTEZS - STK34	Small TPMS Programing Fixture For WRT300sd Or 21230
WRT0BD002	OBD Adapter For Mitsubishi Lancer And Outlander
WRTMT103 - 10	WRTMT 103 - 01 T10 Replacement Bits 5 - Pk
WRTRKIT6	TPMS Train. Kit - 2 DVD With Guides



WRTRST50



WRT0BD002

TPMS RETRO FIT SYSTEMS

TPMS Retrofit Systems. Update Your Vehicle That Did Not Come Equipped With TPMS. With A Dashboard Mounted TPMS Monitor.

Code	Description
20257	Schrader TPMS Retrofit System - Hardwired
20256	Schrader TPMS Retrofit System - Battery
20154	Schrader Replacement Sensor For Retrofit Kit
1502 - 453	Trailer TPMS Kit - For 2 Wheels With 0.453" Rim Hole
1504 - 453	Trailer TPMS Kit - For 4 Wheels With 0.453" Rim Hole
1504 - 572	Trailer TPMS Kit - For 4 Wheels With 0.625" Rim Hole
1506 - 453	Trailer TPMS Kit - For 6 Wheels With 0.453" Rim Hole
1506 - 572	Trailer TPMS Kit - For 6 Wheels With 0.625" Rim Hole
1508 - 453	Trailer TPMS Kit - For 8 Wheels With 0.453" Rim Hole
1508 - 572	Trailer TPMS Kit - For 8 Wheels With 0.625" Rim Hole
1510 - 453	Trailer TPMS Kit - For 10 Wheels With 0.453" Rim Hole
1510 - 572	Trailer TPMS Kit - For 10 Wheels With 0.625" Rim Hole



1504 - 453

TPMS SERVICE TOOLS

TPMS Torque Tools. It Is Always Important For Your Valve Core, Screw Or Nut To Be Torqued To The Recommended Level.

Code	Description
5103	Dill Micrometer Torque Wrench 20 - 200 In/Lbs
5414	Dill TPMS Valve Core Torque Tool
5415	Dill TPMS Snap - In Torque Tool
20137	Schrader Nut Torque Screwdriver
20138	Schrader TPMS Torque Screwdriver With 11 mm And 12 mm Socket
20139	Schrader TPMS Torque Wrench Kit
20140	Schrader TPMS Snap - In T - 10 Torque Tool
20141	Schrader TPMS Valve Core Tool
20142	Schrader Universal Nut Torque Tool
20145	Schrader T - 20 Torque Tool For Beru Sensor
21310	Replacement 11 mm Socket For 20142
21315	Replacement 12 mm Socket For 20142
A - TVCT	TPMS Valve Core Torque Tool
D1F100HA	1/4" Dr Torque Wrench - Dial Face
M1R50H	1/4" Dr Torque Wrench - Click Type
TR25985	TPMS Snap - In T - 10 Torque Tool
TVCT	TPMS Valve Core Torque Tool



5414



20145



20138



TPMS SERVICE TOOLS

TPMS Removal Tools

Code	Description
8910	Dill 3 - Way TPMS Fishing Tool
8911	Dill TPMS Quick Nut Remover
20144	Schrader Grommet Removal Tool
20250	Schrader Cap/Core Removal Tool
30209	Ken - Tool TPMS Sentry Tool



20250

TPMS Mechanical Tool Sets. A Complete Set Of All The Hand Tools Required To Service A Vehicle With TPMS

Code	Description
8100	Dill TPMS Mechanical Tool Kit
WRTMT103 - 01	Replacement T - 10 Torque Tool
WRTMT103 - 02	Replacement T - 20 Torque Tool
WRTMT103 - 03	Replacement Ergonomic Torque Wrench
WRTMT103 - 06	TPMS Digital Tire Pressure Gauge
WRTMT104	Bartec TPMS Mechanical Tool Kit



8100

TPMS CORES, CAPS AND ACCESSORIES

TPMS Valve Dress - Up Kits. Add Chrome Components To Standard Valves In Order To Match Custom Rims.

Code	Description
930 - SC	Dill TPMS Chrome Sleeve And Cap. 4 Of Each Per Pack
22001	Schrader TPMS Aluminum Stem Dress - Up Kit
22005	Schrader TPMS Snap - In Dress - Up Kit
22008	Schrader TPMS Snap - In Chrome Kit With Valve Included



930 - SC

TPMS Valve Cores. These Cores Are Nickel Plated As Brass Cores Seize When Combined With TPMS Valves.

Code	Description
100 - TP	Dill TPMS Valve Core 100/Box
TR25040	TPMS Nickel Plated Core 100/Box
20055	Schrader TPMS Valve Cores 100/Box



100 - TP

TPMS Black And Grey Valve Caps

Code	Description
20195	Schrader TPMS Plastic Valve Caps 25/Bag
20395	Schrader TPMS Plastic Sealing Cap 100/Box
20595	Schrader TPMS Plastic Black Sealing Valve Cap
20995	Schrader Plastic Black Cap for Ford Snap - in
630 - N	Dill TPMS Grey Valve Cap 100/Box
635 - 100	Dill TPMS Cap For Snap - in Sensor
650 - 100	Dill TPMS Small Grey Cap
TI114	TPMS Long Black Plastic Cap 100/Box
TR25306	TPMS Grey Sealing Cap 100/Box



TI114

20595

630 - N



On the winding road of TPMS

Bartec is always **AHEAD** of the curve!



PERFORMANCE YOU EXPECT

DIAGNOSTICS YOU NEED

TECH500

The Industry's First All-In-One, Wireless TPMS Tool

- More TPMS Relearns through OBDII
- Relearns GM, Ford, Chrysler and Volvo through OBDII
- Programs aftermarket replacement sensors
- Properly decodes aftermarket multi-protocol sensors
- Wireless data retrieval to the TPMS Desktop
- Stores TPMS records on tool as well
- Wireless tool charging
- Process driven menu flow
- On-board relearn procedures
- One year's worth of tool updates included
- Sold as a complete kit
- Covers models through 2014



TECH400SD

The Original All-In-One TPMS Tool!

- More TPMS Relearns through OBDII for faster and more accurate repairs
- Relearns GM, Ford, Chrysler and Volvo through OBDII
- Programs aftermarket replacement sensors
- Properly decodes aftermarket multi-protocol sensors
- Process driven menu flow
- On-board relearn procedures
- Generates comprehensive TPMS Audit report
- One year's worth of tool updates included
- Sold as a complete kit
- Covers models through 2014



BARTEC TOOLS DELIVER BOTH!

Ask your Prema Sales person about these other Bartec TPMS products:



- 10 Piece TPMS Mechanical Tool Set
- Mitsubishi Assisted Relearn Kit
- TPMS Consumer Kit
- TPMS Training Kit

Bartec has the RIGHT TPMS tool for YOU !

Bartec TPMS tools have the features and functions that help our customers realize success in TPMS service!

Built to last, Bartec TPMS tools are by far the tools of choice by more tire dealers!

Better Diagnostics - More Coverage - Easier to Use!
All backed by world class TPMS Tech Support!

TECH200

The Industry's First Wireless TPMS Front Counter Tool/Sensor Tester

- Test Sensor before service begins
- Activates sensors for stationary relearns
- Transmit data to the TPMS Desktop
- Programs aftermarket replacement sensors
- Properly decodes aftermarket multi-protocol sensors
- Wireless data retrieval to the TPMS Desktop
- Only entry level tool with Blue tooth
- Ships as complete kit
- Update through the TPMS Desktop
- Covers models through 2014

This easy to use "sensor checker" gives you PIECE OF MIND and your customers confidence that their TPMS Sensors are working Before and After the vehicle is serviced.



Toll Free Tech Support

[866]407-8767

Dedicated To Tire & Wheel Service Technicians Worldwide



Training in
the field and
in the office.



Stocking products
you require.



Our tools are tested
and engineered for their
specific application.



Email
sales@premacanada.ca

www.premacanada.ca

**TPMS CORES, CAPS AND ACCESSORIES***TPMS Green Plastic Valve Caps. Perfect For Letting Your Customers Know That They Are Used For Nitrogen Filled Tire.*

Code	Description
T1119	TPMS Long Green Plastic Cap 100/Box
20695	TPMS Long Plastic Green Sealing Cap 100/Pack
20795	TPMS Plastic Green Sealing Cap 100/Pack

**20695***TPMS Metal Sealing Valve Caps*

Code	Description
20495	Schrader TPMS Metal Sealing Cap 100/Box

**20495***Specialty Deflator Caps. Deflates TPMS Valves Without Removing The Core.*

Code	Description
19860	TPMS Tire Deflator Caps - 4/Pack

**19860***TPMS Parts And Accessories*

Code	Description
1194	Dill TPMS Universal Band .Expands For Rims From 14" - 26"
2 - 1194	TPMS Universal Band . Expands For From 14" - 26"
TPCRADLE	TPMS Cradle - Universal
1025C	Dill TPMS Metal Cradle With Clip
1025 - 10	Dill TPMS Metal Cradle
1026 - 20	Dill TPMS Band ed Sensor - Plastic Clip
1025 - U - 10	Dill TPMS Universal Cradle
20895	Schrader TPMS Replacement T - 10 Screws

**2 - 1194****TPMS LITERATURE AND DISPLAYS**

Code	Description
21380	Schrader TPMS Counter Top Display
9700	Dill TPMS Counter Top Display
TIA - TPMS - 13	TIA TPMS Chart 2013. Complete Lookup Chart With Relearn Procedures
5212	Dill TPMS Handbook 2012. Everything You Need To Know About TPMS
WRTCNK001	Bartec Talking TPMS Consumer Kit. Includes Counter Mat, 2 Different Tri - Folds, Tri - Fold Display , Mouse Pad, 2' X 3' Poster And Banner
WRTCNK0010	How TPMS Works Tri - Fold 25/Pack
WRTCNK0015	What Consumer Should Know Tri - Fold
WRTCNK0020	Tri - Fold Counter Top Display
WRTCNK0025	2' X 3' TPMS Poster
WRTCNK0030	Talking TPMS Counter Mat
WRTCNK0035	TPMS Mouse Pad
WRTCNK0040	Talking TPMS Handbook

**TIA - TPMS - 13**

ATEQ

TPMS Solutions

We turn this  OFF!

VT56 MORE THAN JUST ANOTHER TPMS TOOL!

TPMS EASY AS 1-2-3

01 SCAN VIN



02 TRIGGER SENSORS



03 RELEARN TPMS



HIGHLIGHTS FOR THE VT56

- Bright 4.3" color screen with icon based navigation
- Compatible with all OE, universal and programmable sensors
- Wireless IR printing
- Multiple audit reports

CONTACT US

 **CANADA** (Français)
T.: 1-855-455-TPMS (8767)



www.tpmstools.ca





Wheel Weights



**P WEIGHTS - REGULAR - UNCOATED AND COATED**

The P - Series Lead Clip - On Wheel Weight Is Used On Standard Passenger Car 13"-17" Steel Wheels. Also Available In Coated (PS - Series). Please Refer To Application Guide (Part #18082) And Use Rim Gauge (RGP1) To Verify Specific Applications. Note: Use Our XT - Series Clip - On Wheel Weights For Thinner High - Strength Steel Wheels And Our Tn - Series Clip - On Wheel Weights For Late - Model Light Trucks With Steel Wheels.

**P025 - 100**

Code	Description	Weight (oz)	Qty/Pkg
P025	Passenger Uncoated Weight	0.25	50
P025-100	Passenger Uncoated Weight	0.25	100
P050	Passenger Uncoated Weight	0.5	50
P050-100	Passenger Uncoated Weight	0.5	100
P075	Passenger Uncoated Weight	0.75	50
P075-100	Passenger Uncoated Weight	0.75	100
P100	Passenger Uncoated Weight	1	50
P100-100	Passenger Uncoated Weight	1	100
P125	Passenger Uncoated Weight	1.25	50
P125-100	Passenger Uncoated Weight	1.25	100
P150	Passenger Uncoated Weight	1.5	50
P150-100	Passenger Uncoated Weight	1.5	100
P175	Passenger Uncoated Weight	1.75	50
P200	Passenger Uncoated Weight	2	50
P225	Passenger Uncoated Weight	2.25	50
P250	Passenger Uncoated Weight	2.5	50
P275	Passenger Uncoated Weight	2.75	50
P300	Passenger Uncoated Weight	3	50
P325	Passenger Uncoated Weight	3.25	25
P350	Passenger Uncoated Weight	3.5	25
P375	Passenger Uncoated Weight	3.75	25
P400	Passenger Uncoated Weight	4	25
P450	Passenger Uncoated Weight	4.5	25
P500	Passenger Uncoated Weight	5	25
P550	Passenger Uncoated Weight	5.5	25
P600	Passenger Uncoated Weight	6	25

Code	Description	Weight (oz)	Qty/Pkg
P025S	Passenger Coated Weight	0.25	25
P050S	Passenger Coated Weight	0.5	25
P075S	Passenger Coated Weight	0.75	25
P100S	Passenger Coated Weight	1	25
P125S	Passenger Coated Weight	1.25	25
P150S	Passenger Coated Weight	1.5	25
P175S	Passenger Coated Weight	1.75	25
P200S	Passenger Coated Weight	2	25
P225S	Passenger Coated Weight	2.25	25
P250S	Passenger Coated Weight	2.5	25
P275S	Passenger Coated Weight	2.75	25
P300S	Passenger Coated Weight	3	25

Got a question
about a product?
Looking for something?
Contact Prema at 800.268.6311
or visit
www.premacanada.ca
for answers!



AW WEIGHTS - COATED

The AWN - Series Lead Clip - On Wheel Weight Is Used On Most Domestic Vehicles Equipped With Alloy Rims That Were Manufactured Prior To 1995. Also Available In An Uncoated Finish (AW - Series). Please Refer To Application Guide (Part #18082) And Use Rim Gauge (RGP1) To Verify Specific Applications.

Code	Description	Weight (oz)	Qty/Pkg
AW025N	AWN Coated Weight	0.25	25
AW050N	AWN Coated Weight	0.5	25
AW075N	AWN Coated Weight	0.75	25
AW100N	AWN Coated Weight	1	25
AW125N	AWN Coated Weight	1.25	25
AW150N	AWN Coated Weight	1.5	25
AW175N	AWN Coated Weight	1.75	25
AW200N	AWN Coated Weight	2	25
AW225N	AWN Coated Weight	2.25	25
AW250N	AWN Coated Weight	2.5	25
AW275N	AWN Coated Weight	2.75	25
AW300N	AWN Coated Weight	3	25

Code	Description	Weight (oz)	Qty/Pkg
AW025	AW Uncoated Weight	0.25	25
AW025-50	AW Uncoated Weight	0.25	50
AW050	AW Uncoated Weight	0.5	25
AW050-50	AW Uncoated Weight	0.5	50
AW075	AW Uncoated Weight	0.75	25
AW075-50	AW Uncoated Weight	0.75	50
AW100	AW Uncoated Weight	1	25
AW100-50	AW Uncoated Weight	1	50
AW125	AW Uncoated Weight	1.25	25
AW125-50	AW Uncoated Weight	1.25	50
AW150	AW Uncoated Weight	1.5	25
AW150-50	AW Uncoated Weight	1.5	50
AW175	AW Uncoated Weight	1.75	25
AW200	AW Uncoated Weight	2	25
AW225	AW Uncoated Weight	2.25	25
AW250	AW Uncoated Weight	2.5	25
AW275	AW Uncoated Weight	2.75	25
AW300	AW Uncoated Weight	3	25



IAW WEIGHTS - COATED

Code	Description	Weight (GRAMS)	Qty/Pkg
IAW005	IAW Coated Weight	5	25
IAW010	IAW Coated Weight	10	25
IAW015	IAW Coated Weight	15	25
IAW020	IAW Coated Weight	20	25
IAW025	IAW Coated Weight	25	25
IAW030	IAW Coated Weight	30	25
IAW035	IAW Coated Weight	35	25
IAW040	IAW Coated Weight	40	25
IAW045	IAW Coated Weight	45	25
IAW050	IAW Coated Weight	50	25
IAW055	IAW Coated Weight	55	25
IAW060	IAW Coated Weight	60	25

The IAW - Series Lead Clip - On Wheel Weight Is Used Primarily On Most European And Certain Asian Vehicles Equipped With Alloy Wheels. Please Refer To Application Guide (Part #18082) And Use Rim Gauge (Rgp1) To Verify Specific Applications.

IAW005



AW025





LH WEIGHTS - COATED

The LH - Series Lead Clip - On Wheel Weight Is Used Primarily On Late - Model Chrysler Cars And Is Designed To Fit Their Unique Wheel Flange Profile. Please Refer To Application Guide (Part #18082) And Use Rim Gauge (RGP1) To Verify Specific Applications.

Code	Description	Weight (oz)	Qty/Pkg
LH025	LH Coated Weight	0.25	25
LH050	LH Coated Weight	0.5	25
LH075	LH Coated Weight	0.75	25
LH100	LH Coated Weight	1	25
LH125	LH Coated Weight	1.25	25
LH150	LH Coated Weight	1.5	25
LH175	LH Coated Weight	1.75	25
LH200	LH Coated Weight	2	25
LH225	LH Coated Weight	2.25	25
LH250	LH Coated Weight	2.5	25
LH275	LH Coated Weight	2.75	25
LH300	LH Coated Weight	3	25

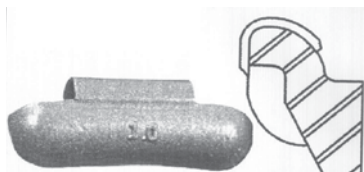

LH025



MC - 100

The MCN - Series Lead Clip - On Wheel Weight Is Used On Most Domestic Vehicles Equipped With Alloy Rims. Also Available In An Uncoated Finish (MC - Series). Please Refer To Application Guide (Part #18082) And Use Rim Gauge (RGP1) To Verify Specific Applications.



MC025

MC WEIGHTS - COATED

Code	Description	Weight (oz)	Qty/Pkg
MC025N	MCN Coated Weight	0.25	25
MC050N	MCN Coated Weight	0.5	25
MC075N	MCN Coated Weight	0.75	25
MC100N	MCN Coated Weight	1	25
MC125N	MCN Coated Weight	1.25	25
MC150N	MCN Coated Weight	1.5	25
MC175N	MCN Coated Weight	1.75	25
MC200N	MCN Coated Weight	2	25
MC225N	MCN Coated Weight	2.25	25
MC250N	MCN Coated Weight	2.5	25
MC275N	MCN Coated Weight	3.75	25
MC300N	MCN Coated Weight	3	25
MC325N	MCN Coated Weight	3.25	25
MC350N	MCN Coated Weight	3.5	25
MC375N	MCN Coated Weight	3.75	25
MC400N	MCN Coated Weight	4	25

Code	Description	Weight (oz)	Qty/Pkg
MC025	MC Uncoated Weight	0.25	25
MC025 - 50	MC Uncoated Weight	0.25	50
MC050	MC Uncoated Weight	0.5	25
MC050 - 50	MC Uncoated Weight	0.5	50
MC075	MC Uncoated Weight	0.75	25
MC075 - 50	MC Uncoated Weight	0.75	50
MC100	MC Uncoated Weight	1	25
MC100 - 50	MC Uncoated Weight	1	50
MC125	MC Uncoated Weight	1.25	25
MC125 - 50	MC Uncoated Weight	1.25	50
MC150	MC Uncoated Weight	1.5	25
MC150 - 50	MC Uncoated Weight	1.5	50
MC175	MC Uncoated Weight	1.75	25
MC200	MC Uncoated Weight	2	25
MC225	MC Uncoated Weight	2.25	25
MC250	MC Uncoated Weight	2.5	25
MC275	MC Uncoated Weight	2.75	25
MC300	MC Uncoated Weight	3	25



FN WEIGHTS

The FN - Series Lead Clip - On Wheel Weight Is Used Primarily On Most Japanese Vehicles Equipped With Alloy Wheels That Were Manufactured Prior To 1990. Please Refer To Application Guide (Part #18082) And Use Rim Gauge (RGP1) To Verify Specific Applications.



Code	Description	Weight (Grams)	Qty/Pkg
FN005	FN Coated Weight	5	25
FN010	FN Coated Weight	10	25
FN015	FN Coated Weight	15	25
FN020	FN Coated Weight	20	25
FN025	FN Coated Weight	25	25
FN030	FN Coated Weight	30	25
FN035	FN Coated Weight	35	25
FN040	FN Coated Weight	40	25
FN045	FN Coated Weight	45	25
FN050	FN Coated Weight	50	25
FN055	FN Coated Weight	55	25
FN060	FN Coated Weight	60	25
FN065	FN Coated Weight	65	25
FN070	FN Coated Weight	70	25
FN075	FN Coated Weight	75	25
FN080	FN Coated Weight	80	25

The Tn - Series Lead Clip - On Wheel Weight Is Used Primarily On Most Domestic Light Trucks Equipped With Decorative And Larger - Thickness Steel Wheels And Most Late - Model Light Trucks Equipped With Alloy Wheels. Please Refer To Application Guide (Part #18082) And Use Rim Gauge (Rgp1) To Verify Specific Applications.



EN WEIGHTS

Code	Description	Weight (Grams)	Qty/Pkg
EN010	EN Coated Weight	10	25
EN015	EN Coated Weight	15	25
EN020	EN Coated Weight	20	25
EN025	EN Coated Weight	25	25
EN030	EN Coated Weight	30	25
EN035	EN Coated Weight	35	25
EN040	EN Coated Weight	40	25
EN045	EN Coated Weight	45	25
EN050	EN Coated Weight	50	25
EN055	EN Coated Weight	55	25
EN060	EN Coated Weight	60	25

The EN - Series lead clip - on wheel weight is used primarily on Audi, Mercedes Benz and early - model Japanese vehicles equipped with alloy wheels. Please refer to Application Guide (Part # 18082) and use rim gauge (RGP1) to verify specific applications.



MEDIUM And H.D. TRUCK WEIGHTS

The LT1 - Series Lead Clip - On Wheel Weight Is Used Primarily On Light - Duty Trucks, ¾ And 1 - Ton Vehicles, With Either Tube Or Tubeless Rims Where Such Rims Are Too Thick For Standard Passenger Car Weights. Also For Use On Heavier Trucks With Thin Rim Flanges. Please Use Rim Gauge (Rg2) To Verify Specific Applications.



Code	Description	Weight (oz)	Qty/Pkg
LT1005	LT1 Weight	0.5	25
LT1010	LT1 Weight	1	25
LT1015	LT1 Weight	1.5	25
LT1020	LT1 Weight	2	25
LT1025	LT1 Weight	2.5	25
LT1030	LT1 Weight	3	25
LT1035	LT1 Weight	3.5	25
LT1040	LT1 Weight	4	25
LT1045	LT1 Weight	4.5	25
LT1050	LT1 Weight	5	25
LT1060	LT1 Weight	6	25

TN WEIGHTS COATED

Code	Description	Weight (oz)	Qty/Pkg
T025N	TN Coated Truck Weight	0.25	25
T050N	TN Coated Truck Weight	0.5	25
T075N	TN Coated Truck Weight	0.75	25
T100N	TN Coated Truck Weight	1	25
T125N	TN Coated Truck Weight	1.25	25
T150N	TN Coated Truck Weight	1.5	25
T175N	TN Coated Truck Weight	1.75	25
T200N	TN Coated Truck Weight	2	25
T225N	TN Coated Truck Weight	2.25	25
T250N	TN Coated Truck Weight	2.5	25
T275N	TN Coated Truck Weight	2.75	25
T300N	TN Coated Truck Weight	3	25
T325N	TN Coated Truck Weight	3.25	25
T350N	TN Coated Truck Weight	3.5	25
T375N	TN Coated Truck Weight	3.75	25
T400N	TN Coated Truck Weight	4	25



17 WEIGHTS

Code	Description	Weight (oz)	Qty/Pkg
I7010	I7 Weight	1	10
I7020	I7 Weight	2	10
I7025	I7 Weight	2.5	25
I7030	I7 Weight	3	10
I7035	I7 Weight	3.5	25
I7040	I7 Weight	4	10
I7050	I7 Weight	5	10
I7060	I7 Weight	6	10
I7080	I7 Weight	8	10
I7100	I7 Weight	10	10
I7120	I7 Weight	12	10
I7140	I7 Weight	14	10
I7160	I7 Weight	16	10

The I7 - Series Lead Clip - On Wheel Weight Is The Most Popular Wheel Weight For Medium And Heavy - Duty Trucks. It Is Used On The Majority Of Trucks With Tube - Type Tires. Please Use Rim Gauge (RG2) To Verify Specific Applications.



TAL WEIGHTS

Code	Description	Weight (oz)	Qty/Pkg
TAL020	TALS Coated Weight	2	10
TAL030	TALS Coated Weight	3	10
TAL040	TALS Coated Weight	4	10
TAL060	TALS Coated Weight	6	10
TAL080	TALS Coated Weight	8	10
TAL030U	TAL Uncoated Weight	3	10
TAL040U	TAL Uncoated Weight	4	10
TAL060U	TAL Uncoated Weight	6	10
TAL080U	TAL Uncoated Weight	8	10



The Tal - Series Lead Clip - On Wheel Weight Is For All Alcoa And Accuride Aluminium, Tubeless Heavy Truck Wheels Manufactured Since 1983. The Wheel Weight Will Fit Both Sides Of The Wheel. Also Available In An Uncoated Finish (Talu - Series). Please Use Rim Gauge (Rg2) To Verify Specific Applications.

RC TRUCK WEIGHTS

Code	Description	Weight (oz)	Qty/Pkg
RC020	RC Weight	2	10
RC030	RC Weight	3	10
RC040	RC Weight	4	10
RC060	RC Weight	6	10
RC080	RC Weight	8	10
RC120	RC Weight	12	10

The RC - Series Lead Clip - On Wheel Weight Is Used On Heavy - Duty Trucks With Firestone, Accuride, Or Radical Commander Rims. It Can Also Be Used With Strip - Steel Rims With Curved Flanges, Such As Budd, Firestone, Goodyear And Redco. Please Use Rim Gauge (RG2) To Verify Specific Applications.

CT TRUCK WEIGHTS

Code	Description	Weight (oz)	Qty/Pkg
CT020	CT Weight	2	10
CT030	CT Weight	3	10
CT040	CT Weight	4	10
CT060	CT Weight	6	10
CT080	CT Weight	8	10
CT100	CT Weight	10	10
CT120	CT Weight	12	10
CT140	CT Weight	14	10

The CT - Series Clip - On Wheel Weight Is Used On Heavy - Duty Trucks With Firestone, Accuride, Budd, Or Goodyear Tubeless Rims With Straight Flanges. Primarily Used On Rim Widths Of 6.75", 7.50" And 8.25". Please Use Rim Gauge (RG2) To Verify Specific Applications.



CT020



ADHESIVE WEIGHTS - PERFECT

Code	Description	Weight (Grams)	Qty/Pkg
RU005C	RUC Coated Wide Adhesive Weight	5	25
RU010C	RUC Coated Wide Adhesive Weight	10	25
RU015C	RUC Coated Wide Adhesive Weight	15	25
RU020C	RUC Coated Wide Adhesive Weight	20	25
RU025C	RUC Coated Wide Adhesive Weight	25	25
RU030C	RUC Coated Wide Adhesive Weight	30	25
RU035C	RUC Coated Wide Adhesive Weight	35	25
RU040C	RUC Coated Wide Adhesive Weight	40	25
RU045C	RUC Coated Wide Adhesive Weight	45	25
RU050C	RUC Coated Wide Adhesive Weight	50	25
RU055C	RUC Coated Wide Adhesive Weight	55	25
RU060C	RUC Coated Wide Adhesive Weight	60	25

ADHESIVE WHEEL WEIGHTS

Code	Description	Weight (Grams)
100360	Pre-Taped Adhesive Weight	1/4 oz segments in a 3 oz strip. 30 strips / box.
100360B	Pre-Taped Coated Black Adhesive Weight	1/4 oz segments in a 3 oz strip. 30 strips / box.
100360C	Pre-Taped Coated Chrome Adhesive Weight	1/4 oz segments in a 3 oz strip. 30 strips / box.
100360S	Pre-Taped Coated Silver Adhesive Weight	1/4 oz segments in a 3 oz strip. 30 strips / box.
100360W	Pre-Taped Coated White Adhesive Weight	1/4 oz segments in a 3 oz strip. 30 strips / box.

Code	Description	Weight (Grams)
200624	Pre-Taped Low Profile Adhesive Weight	1/4 oz segments in a 3 oz strip. 52 strips / box.
200624N	Pre-Taped Coated Low Profile Adhesive Weight	1/4 oz segments in a 3 oz strip. 52 strips / box.
200624HP	Pre-Taped Low Profile Adhesive Weight W/ 3M Tape	1/4 oz segments in a 3 oz strip. 52 strips / box.

Code	Description	Weight (Grams)
100720	Pre-Taped Adhesive Weight	1/2 oz segments in a 5 oz strip. 30 strips / box.
300360	Pre-Taped Adhesive Truck Weight	1/2 oz segments in a 6 oz strip. 30 strips / box.

Code	Description	Weight (Grams)
CL6	Pre-Taped Adhesive Truck Weight	1 oz segments in a 6 oz strip. 30 strips / box.

Code	Description	Weight (Grams)
CL12	Adhesive Truck Weight	2 oz segments in a 12 oz strip. 8 strips / box.

The 100360 Quikstik® Lead Adhesive Wheel Weight Is A Standard Profile Adhesive Weight Made For Use On Most Wheel Types Where A Clip - On Wheel Weight Is Not Available Or Not Preferred. All Perfect Equipment Quikstik® Lead Adhesive Wheel Weights Are Pre - Cut And Pre - Taped. There Is No Cutting, No Pre - Contouring And No Waste! They Also Feature The Patented Quiktab® (Us Patent #6,364,421), Which Makes Separating The Protective Backing From The Adhesive Strip On The Weight Effortless. The Protective Backing Is Wider Than The Weight, Allowing For An Easier And Quicker Installation.



ADHESIVE WEIGHTS - ZINC



Code	Discription	Weight (Grams)
H380	Zinc Adhesive Wheel Weight Silver	60
H380BK	Zinc Adhesive Wheel Weight Black	60
H380CH	Zinc Adhesive Wheel Weight Chrome	60
H380RD	Zinc Adhesive Wheel Weight Red	60
H380AN	Zinc Adhesive Wheel Weight Anthracite	60
H380WH	Zinc Adhesive Wheel Weight White	60
H380BL	Zinc Adhesive Wheel Weight Blue	60
H380YE	Zinc Adhesive Wheel Weight Yellow	60
H380OR	Zinc Adhesive Wheel Weight Orange	60
HK380M1	Zinc Adhesive Wheel Weight Pos - Multi Pack	
HK380AN	Zinc Adhesive Wheel Weight Pos - Anthracite	
HK380BK	Zinc Adhesive Wheel Weight Pos - Black	
HK380BL	Zinc Adhesive Wheel Weight Pos - Blue	
HK380CH	Zinc Adhesive Wheel Weight Pos - Chrome	
HK380OR	Zinc Adhesive Wheel Weight Pos - Orange	
HK380RD	Zinc Adhesive Wheel Weight Pos - Red	
HK380WH	Zinc Adhesive Wheel Weight Pos - White	
HK380YE	Zinc Adhesive Wheel Weight Pos - Yellow	
H361005	Zinc Adhesive Wheel Weight HPW Wide Base	5
H361010	Zinc Adhesive Wheel Weight HPW Wide Base	10
H361015	Zinc Adhesive Wheel Weight HPW Wide Base	15
H361020	Zinc Adhesive Wheel Weight HPW Wide Base	20
H361025	Zinc Adhesive Wheel Weight HPW Wide Base	25
H361030	Zinc Adhesive Wheel Weight HPW Wide Base	30
H361035	Zinc Adhesive Wheel Weight HPW Wide Base	35
H361040	Zinc Adhesive Wheel Weight HPW Wide Base	40
H361045	Zinc Adhesive Wheel Weight HPW Wide Base	45
H361050	Zinc Adhesive Wheel Weight HPW Wide Base	50
H361055	Zinc Adhesive Wheel Weight HPW Wide Base	55
H361060	Zinc Adhesive Wheel Weight HPW Wide Base	60
H360005	Zinc Adhesive Wheel Weight HPW Narrow Double GRV	5
H360010	Zinc Adhesive Wheel Weight HPW Narrow Double GRV	10
H360015	Zinc Adhesive Wheel Weight HPW Narrow Double GRV	15
H360020	Zinc Adhesive Wheel Weight HPW Narrow Double GRV	20
H360025	Zinc Adhesive Wheel Weight HPW Narrow Double GRV	25
H360030	Zinc Adhesive Wheel Weight HPW Narrow Double GRV	30
H360035	Zinc Adhesive Wheel Weight HPW Narrow Double GRV	35
H360040	Zinc Adhesive Wheel Weight HPW Narrow Double GRV	40
H360045	Zinc Adhesive Wheel Weight HPW Narrow Double GRV	45
H360050	Zinc Adhesive Wheel Weight HPW Narrow Double GRV	50
H360055	Zinc Adhesive Wheel Weight HPW Narrow Double GRV	55
H360060	Zinc Adhesive Wheel Weight HPW Narrow Double GRV	60

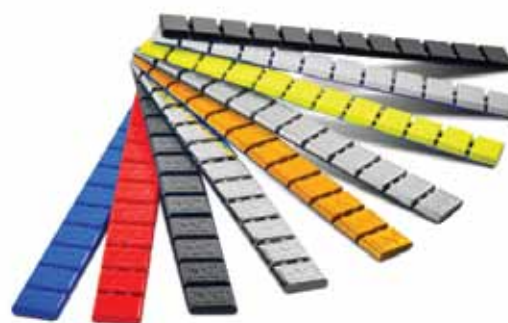



ADHESIVE WEIGHTS STEEL - PERFECT

The SST300N Quikstik® Steel Adhesive Wheel Weight Is A Standard Profile Adhesive Weight Made For Use On Most Wheel Types Where A Clip - On Wheel Weight Is Not Available Or Not Preferred. All Perfect Equipment Quikstik® Steel Adhesive Wheel Weights Feature The Exclusive Isosceles Trapezoid Segment Design, Allowing The Weight To Easily Contour To The Shape Of The Rim And The Patented Quiktab® (US Patent #6,364,421), Which Makes Separating The Protective Backing From The Adhesive Strip On The Weight Effortless. The Protective Backing Is Wider Than The Weight, Allowing For An Easier And Quicker Installation.

Code	Description
SST300N	Steel Adh. Wheel Weight - Standard Profile



SST300N

The 200624ST Quikstik® Lead Adhesive Wheel Weight Is A Low Profile Adhesive Weight Made For Use On Most Wheel Types Where A Clip - On Wheel Weight Is Not Available Or Not Preferred And Where There Is Not Enough Brake Caliper Clearance For Standard Profile Quikstik® Adhesive Weights. All Perfect Equipment Quikstik® Lead Adhesive Wheel Weights Are Pre - Cut And Pre - Taped. There Is No Cutting, No Pre - Contouring And No Waste! They Also Feature The Patented Quiktab® (Us Patent #6,364,421), Which Makes Separating The Protective Backing From The Adhesive Strip On The Weight Effortless. The Protective Backing Is Wider Than The Weight, Allowing For An Easier And Quicker Installation.

Code	Description
200624ST	Steel Low Profile Wheel Weight Coated



200624ST

The 200624STR Quikstik® Steel Adhesive Wheel Weight Is A Low Profile Adhesive Weight Roll, Featuring 1,250 Segments Per Box, Made For Use On Most Wheel Types Where A Clip - On Wheel Weight Is Not Available Or Not Preferred And Where There Is Not Enough Brake Caliper Clearance For Standard Profile Quikstik® Adhesive Weights. All Perfect Equipment Quikstik® Steel Adhesive Wheel Weights Feature The Exclusive Isosceles Trapezoid Segment Design, Allowing The Weight To Easily Contour To The Shape Of The Rim And The Patented Quiktab® (Us Patent #6,364,421), Which Makes Separating The Protective Backing From The Adhesive Strip On The Weight Effortless. The Protective Backing Is Wider Than The Weight, Allowing For An Easier And Quicker Installation.

Code	Description
200624STR	Steel Low Profile Wheel Weight Coated



200624STR

The 300360ST Quikstik® Steel Adhesive Wheel Weight Is A Standard Profile Adhesive Weight Made For Use On Most Truck And RV Wheel Types Where A Clip - On Wheel Weight Is Not Available Or Not Preferred. All Perfect Equipment Quikstik® Steel Adhesive Wheel Weights Feature The Exclusive Isosceles Trapezoid Segment Design, Allowing The Weight To Easily Contour To The Shape Of The Rim And The Patented Quiktab® (Us Patent #6,364,421), Which Makes Separating The Protective Backing From The Adhesive Strip On The Weight Effortless. The Protective Backing Is Wider Than The Weight, Allowing For An Easier And Quicker Installation.

Code	Description
200624STB	Steel Low Profile Wheel Weight Coated

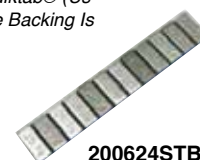

200624STB

The SSG060N Quikstik® Steel Adhesive Wheel Weight Is A Low Profile Adhesive Weight Made For Use On Most Wheel Types Where A Clip - On Wheel Weight Is Not Available Or Not Preferred And Where There Is Not Enough Brake Caliper Clearance For Standard Profile Quikstik® Adhesive Weights. All Perfect Equipment Quikstik® Steel Adhesive Wheel Weights Feature The Exclusive Isosceles Trapezoid Segment Design, Allowing The Weight To Easily Contour To The Shape Of The Rim And The Patented Quiktab® (Us Patent #6,364,421), Which Makes Separating The Protective Backing From The Adhesive Strip On The Weight Effortless. The Protective Backing Is Wider Than The Weight, Allowing For An Easier And Quicker Installation.

Code	Description
SSG060N	Steel Low Profile Wheel Weight Coated

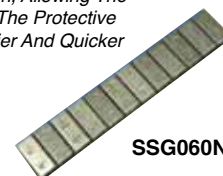

SSG060N

The 300360ST Quikstik® Steel Adhesive Wheel Weight Is A Standard Profile Adhesive Weight Made For Use On Most Truck And RV Wheel Types Where A Clip - On Wheel Weight Is Not Available Or Not Preferred. All Perfect Equipment Quikstik® Steel Adhesive Wheel Weights Feature The Exclusive Isosceles Trapezoid Segment Design, Allowing The Weight To Easily Contour To The Shape Of The Rim And The Patented Quiktab® (Us Patent #6,364,421), Which Makes Separating The Protective Backing From The Adhesive Strip On The Weight Effortless. The Protective Backing Is Wider Than The Weight, Allowing For An Easier And Quicker Installation.

Code	Description
300360ST	Steel Low Profile Wheel Weight Coated



300360ST



ADHESIVE WEIGHTS STEEL - IMPORT

Excellent Imported Lead - Free Alternative To Conventional Wheel Weights. Plastic Coated Steel Segments. Available In Rolls.

Code	Description
SADHS25C	Steel Adhesive Weight 1/4 oz Strip Coated
SADHS50C	Steel Adhesive Weight 1/2 oz Strip Coated
SADHR25C	Steel Adhesive Weight 1/4 oz Roll 11 lbs
SADHS100C	Steel Adhesive Weight 1 oz Strip 18/Box
SADHR - COMP	Steel Adhesive Weight 11 lbs Roll With Holder



SADHR - COMP

Steel Tape Wheel Weight Holder

Code	Description
SADHR - HOLDER	Steel Tape Wheel Weight Holder



SADHR - HOLDER

ADHESIVE WEIGHTS - 3M

3M Wheel Weight. 7 mm X 15 mm. 5 Pounds Per Roll. Standard Height At 7 mm Tall But Only 15 mm Wide Footprint On The Wheel Is Small. Have To Be Careful For Caliper Clearance With This At 7 mm High.

Code	Description
3M - 61400	3M Wheel Weight. Narrow Profile. 7 mm Tall X 15 mm Wide



3M - 61400

3M Wheel Weight. 7 mm X 15 mm. 12 Pounds Per Roll. Standard Height At 7 mm Tall But Only 15 mm Wide The Footprint On The Wheel Is Small II. Have To Be Careful For Caliper Clearance With This At 7 mm High.

Code	Description
3M - 61403	3M Wheel Weight. Standard. 7 mm Tall X 15 mm Wide



3M - 61403

3M Wheel Weight. 4 mm X 23 mm. 5 Pounds Per Roll. Low Profile At 4 mm Tall But At 23 mm Wide Means The Footprint On The Wheel Is Larger. No Caliper Clearance Problems At Only 4 mm High.

Code	Description
3M - 61404	3M Wheel Weight. Low Profile. 4 mm Tall X 23 mm Wide

3M Wheel Weight. 4 mm X 23 mm . 20 Pounds Per Roll. Low Profile At 4 mm Tall But At 23 mm Wide Means The Footprint On The Wheel Is Larger. No Caliper Clearance Problems At Only 4 mm High.

Code	Description
3M - 61405	3M Wheel Weight. Low Profile. 7 mm Tall X 23 mm Wide



3M - 61405

3M Wheel Weight. 7 mm X 14 mm . 10 Pounds Per Roll. This Is Considerered A Mechanical Style And Is Made To Replace Clip - On Type Weights. This Is An Adhesive Backed Weight But Is Actually Installed In The Wheel Flange Like A Clip - On Weight. New Innovation!

Code	Description
3M - 99427	3M Wheel Weight. Mechanical Style. 7 mm Tall X 14 mm Wide



3M - 99427

3M Wheel Weight. 7 mm X 14 mm. 5 Pounds Per Roll. This Is Considerered A Mechanical Style And Is Made To Replace Clip - On Type Weights. This Is An Adhesive Backed Weight But Is Actually Installed In The Wheel Flange Like A Clip - On Weight. New Innovation!

Code	Description
3M - 99438	3M Wheel Weight. Mechanical Style. 7 mm Tall X 14 mm Wide



ADHESIVE WEIGHTS STEEL - 3M

3M Wheel Weight. 6 mm X 29 mm X 11 mm. 20Pounds Per Roll. Wide Profile At 6 mm Tall But At 29 mm Wide Means The Footprint On The Wheel Is Larger. OE Weight On Some Newer GM Platforms Ie: Tahoe, Sierra, Yukon.

Code	Description
3M - 99473	3M Wheel Weight. Wide Profile. 6 mm Tall X 29 mm Wide



3M - 61458

3M ADHESIVE WEIGHT ACCESSORIES

Code	Description
3M - 61458	3M Wheel Weight Surface Prep 90 ml Bottle
3M - 99099	3M Wheel Weight Removal Tool
3M - 61480	3M Cutting Stand
3M - 61479	3M Universal Cutter
3M - 99428	3M Dual Holder Kit
3M - 99429	3M Dual Cutter Bracket
3M - 61565	3M Replacement Scale Standard Profile
3M - 61566	3M Replacement Scale Standard Profile



3M - 99429



3M - 61479

WEIGHT ASSORTMENTS PERFECT

Mini Assortment Of Coated Weights In A Large Plastic Compartment Bin With Cover. Adjustable Sliders. Maximum Compartment Storage 24 Slots. Dimension 13 - 1/8" W X 2 - 5/16" H X 9" D.

Code	Description
CWWAWN	Mini Assortment Case - AW Coated
CWWMCN	Mini Assortment Case - MC Coated
CWWLH	Mini Assortment Case - LH Coated
CWWTN	Mini Assortment Case - TN Coated
CWWIAW	Mini Assortment Case - IAW Coated
CWWEN	Mini Assortment Case - EN Coated
CWWFN	Mini Assortment Case - FN Coated



3M - 99428

The CWW150 Lead Wheel Weight, Tabletop Master Assortment Is A Comprehensive Weight Kit That Includes All Seven Standard Weight Types Needed For Today's Passenger Car Market. This Kit Serves As A Practical Starter Kit For Most Installers. Comes Complete With A Tabletop Rack With Ample Storage Space For The Perfect Equipment Inventory, Colour - Coded Bins To Make Weight Identification Quick And Easy. Additional Installation Tools And Educational Information Is Also Included.

Code	Description
CWW150	Mini Assortment Kit - Coated Only
CWW150E	Mini Assortment Kit - Empty



CWWAWN



CWWAWN



WEIGHT ASSORTMENTS PERFECT

The CWW074 And CWW075 Lead Wheel Weight Master Assortments Are Comprehensive Weight Kits That Include All Seven Standard Weight Types Needed For Today's Passenger Car Market. Both Come Complete With A Floor - Standing Rack With Ample Storage Space For The Perfect Equipment Inventory Colour - Coded Bins To Make Weight Identification Quick And Easy. Additional Installation Tools And Educational Information Are Also Included.

Code	Description
CWW074	Special Alloy Weight Assortment
CWW075	Master Alloy Weight Assortment
CWW075E	Master Asst Kit - Empty



CWW074

The CWW060 Lead Wheel Weight, Tabletop Assortment Is A Comprehensive Heavy - Duty Truck Wheel Weight Kit. This Kit Will Provide Ample Coverage For Most Medium And Heavy - Duty Trucks And RVS On The Road Today. Comes Complete With A Tabletop Rack With Ample Storage Space For The Perfect Equipment Inventory, Colour - Coded Bins To Make Weight Identification Quick And Easy. Additional Installation Tools And Educational Information Is Also Included.

Code	Description
CWW060	Truck Wheel Weight Assortment
CWW060E	Truck Wheel Weight Assortment - Empty



CWW060

The CWW060 Lead Wheel Weight, Tabletop Assortment Is A Comprehensive Heavy - Duty Truck Wheel Weight Kit. This Kit Will Provide Ample Coverage For Most Medium And Heavy - Duty Trucks And RVS On The Road Today. Comes Complete With A Tabletop Rack With Ample Storage Space For The Perfect Equipment Inventory, Colour - Coded Bins To Make Weight Identification Quick And Easy. Additional Installation Tools And Educational Information Is Also Included.

Code	Description
CWW060	Truck Wheel. Weight Assortment
CWW060E	Truck Wheel. Weight Assortment - Empty



MB - 220 - GY

Wheel Weight Replacement Bins

Code	Description
MB - 220 - RD	Medium Bin Red
MB - 220 - YL	Medium Bin Yellow
MB - 220 - PL	Medium Bin Purple
MB - 220 - BL	Medium Bin Blue
MB - 220 - GR	Medium Bin Green
MB - 220 - OR	Medium Bin Orange
MB - 220 - GY	Medium Bin Grey
MB - 220 - BK	Medium Bin Black
40 - 220 - M	Medium Wheel Weight Replacement Bin Divider

Wheel Weight Replacement Bins

Code	Description
SB - 210 - RD	Small Bin Red
SB - 210 - YL	Small Bin Yellow
SB - 210 - PL	Small Bin Purple
SB - 210 - BL	Small Bin Blue
SB - 210 - GR	Small Bin Green
SB - 210 - OR	Small Bin Orange
SB - 210 - GY	Small Bin Grey
SB - 210 - BK	Small Bin Black



SB - 210 - YL



WEIGHT ASSORTMENTS - MISC

Wheel Weight Measurement Gauge

Code	Description
RG2	Truck Wheel Weight Measuring Gauge
RGP1	Passenger/LT Wheel Weight Measuring Gauge



RG2

Code	Description
CWW035E	Empty Plastic Assortment Bin With Cover
MPB - 314 - 36	Multi - Purpose 36 Hole Steel Bin
MPB - 319 - 18	Multi - Purpose 18 Hole Steel Bin



CWW035E

Multi - Purpose Bins

Code	Description
JL106HZ	40 Section Multi - Purpose Bin
JL106VT	40 Section Multi - Purpose Bin
JL108HZ	20 Section Multi - Purpose Bin



JL106HZ



MPB - 314 - 36



MPB - 319 - 18

Got a question about a product?
 Looking for something?
 Contact Prema at 800.268.6311
 or visit www.premacanada.ca
 for answers!

HPW TYPE 380

ADHESIVE WHEEL BALANCE WEIGHT IN NINE COLORS

ADD STYLE & PERFORMANCE

- Turn wheel weights into a profit!
- Sell the Type 380 colored wheel weight to your customers as an additional add-on
- Looks great on aftermarket wheel and tire combinations
- Made from Premium Zinc
- HOFMANN is the OEM supplier to brands like Porsche, Ferrari, Bentley, BMW and many others
- German engineered & track proven!

Our new Type 380 premium balancing weight was developed for motor sports and offers the highest performance for the toughest demands. Produced to OE standards and optimized for the technician, the Type 380 weight has a resilient powder coating for permanent corrosion protection. With its patented production procedure, the Type 380 adhesive weight is easy to attach and perfectly adapts to the rim contour. With 12 segments of 5 grams each, it can be easily counted and then divided by the perforated adhesive tape if required.

Dimensions: 6.75" (length) x 0.75" (width)
 Total height including adhesive tape: 0.16"
 Weight: 60 gram strips (5g x 12)

P.O.S. DISPLAY

The NEW P.O.S. Display unit for the HOFMANN Power Weight Type 380 features 24 individual retail packs. Each pack includes six 60g sticks of colored Type 380, enough to balance most standard size passenger cars & trucks. Each retail pack has it's own UPC code for counter scanning. Give your customers a new upgrade option, one that they have never had before. Be different than your competition. Start today.

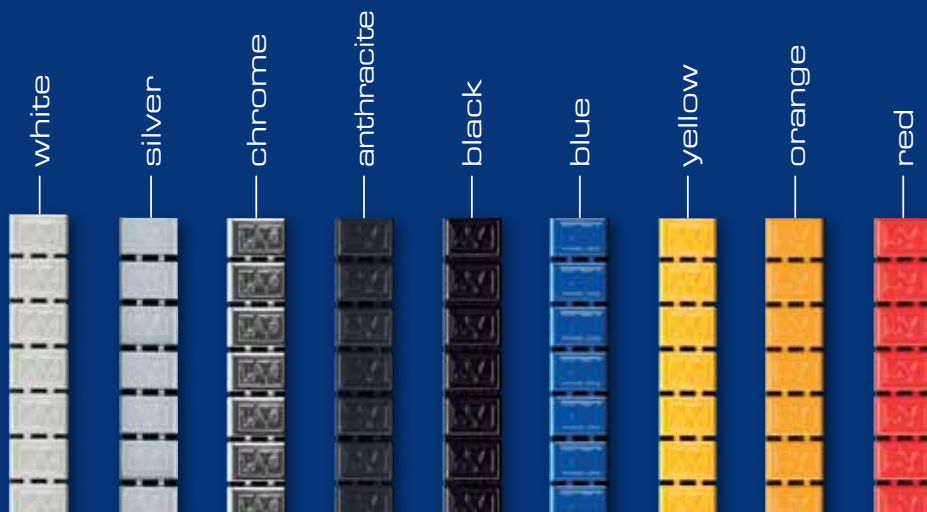
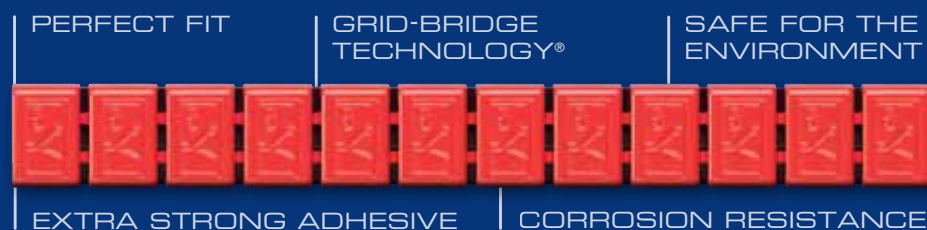



Valves





RUBBER SNAP - IN VALVES

Snap - In Passenger Tubeless Valve Tire Valve For .453" Valve Hole. Tr#412 Length 7/8" (25 mm)

Code	Description
A - 412 - 100	Snap - In Tubeless Valves - TR412
412 - 50	Snap - In Tubeless Valves - TR412



A - 412 - 100

Snap - In Passenger Tubeless Valve Tire Valve For .453" Valve Hole. Tr#413 Length 1 - 1/4" (30 mm)

Code	Description
A - 413 - 500	Snap - In Tubeless Valves - TR413
413 - 50	Snap - In Tubeless Valves - TR413



A - 413 - 500

Snap - In Passenger Tubeless Valve Tire Valve For .453" Valve Hole. Tr#412 Length 1 - 1/2" (40 mm)

Code	Description
A - 414 - 500	Snap - In Tubeless Valves - TR414
414 - 50	Snap - In Tubeless Valves - TR414



414 - 50

Snap - In Passenger Tubeless Valve Tire Valve For .453" Valve Hole. Tr#412 Length 2" (50 mm)

Code	Description
A - 418 - 500	Snap - In Tubeless Valves - TR418
418 - 50	Snap - In Tubeless Valves - TR418



A - 418 - 500

Snap - In Passenger Tubeless Valve Tire Valve For .453" Valve Hole. Tr#412 Length 2 - 1/2" (65 mm)

Code	Description
A - 423 - 100	Snap - In Tubeless Valves - TR423
423 - 50	Snap - In Tubeless Valves - TR423



423 - 50

Snap - In Passenger Tubeless Valve Tire Valve For .625" Valve Hole. Tr#412 Length 1 - 1/4" (30 mm)

Code	Description
A - 415 - 100	Snap - In Tubeless Valves - TR415
415 - 50	Snap - In Tubeless Valves - TR415



A - 425 - 100

Snap - In Passenger Tubeless Valve Tire Valve For .625" Valve Hole. Tr#412 Length 2" (50 mm)

Code	Description
A - 425 - 100	Snap - In Tubeless Valves - TR425

Rubber snap - in valve (TR438) for small 8.8 mm valve hole.

Code	Description
A - 438	TR438 Rubber Snap - In Valve 8.8 mm



A - 438



TUBELESS TRUCK VALVES TR500 SERIES

Truck And Bus Tubless Valve, Clamp - In Type For 5/8" (.625") Valve Holes. TR# 500. Length 2" (50 mm)

Code	Description
A - 575 - 10	Snap - In Tubeless Valves - TR575



A - 575 - 10

Truck And Bus Tubeless Valve, Straight Clamp - In Type For Side Valve Holes On Demountable And Non - Demountable Rims With Standard 5/8" (.625") Valve Hole. High Quality Ozone Resistant Rubber Grommet Achieves Air - Tight Seal. TR# 500. Length 2" (50 mm)

Code	Description
A - 501 - 100	Tubeless Truck - TR501
501 - 100	Tubeless Truck - TR501



A - 501 - 100

Truck And Bus Tubeless Valve, Straight Clamp - In Type For Side Valve Holes On Demountable And Non - Demountable Rims With Standard 5/8" (.625") Valve Hole. High Quality Ozone Resistant Rubber Grommet Achieves Air - Tight Seal. TR# 500. Length 2" (50 mm)

Code	Description
A - 500 - 10	Tubeless Truck - TR500
EX - 1296B	Tubeless Truck - TR500



A - 500 - 10

Truck And Bus Tubeless Valve, Straight Clamp - In Type For Side Valve Holes On Demountable And Non - Demountable Rims With Standard 5/8" (.625") Valve Hole. High Quality Ozone Resistant Rubber Grommet Achieves Air - Tight Seal. TR# 570. Length 3 - 1/8" (80 mm)

Code	Description
EX - 1296C	Tubeless Truck - TR570
570 - 10	Tubeless Truck - TR570



EX - 1296B

Truck And Bus Tubless Valve, Clamp - In Type For 5/8" (.625") Valve Holes. TR# 571. Length 3 - 3/4" (95 mm)

Code	Description
A - 571 - 10	Tubeless Truck - TR571



570 - 10

Truck And Bus Tubeless Valve, Straight Clamp - In Type For Side Valve Holes On Demountable And Non - Demountable Rims With Standard 5/8" (.625") Valve Hole. High Quality Ozone Resistant Rubber Grommet Achieves Air - Tight Seal. TR# 572. Length 3 - 3/4" (95 mm)

Code	Description
A - 572 - 100	Tubeless Truck - TR572
EX - 1296E	Tubeless Truck - TR572
EX - 1296E - 13	TR572 Truck Valve With 13°
572 - 100	Tubeless Truck - TR572
VS - 572 - F19	TR572 Truck Valve With 31°



VS - 572 - F19

Truck And Bus Tubeless Valve, Straight Clamp - In Type For Side Valve Holes On Demountable And Non - Demountable Rims With Standard 5/8" (.625") Valve Hole. High Quality Ozone Resistant Rubber Grommet Achieves Air - Tight Seal. TR# 573. Length 4 - 3/8" (110 mm)

Code	Description
A - 573 - 100	Tubeless Truck - TR573
A - 57325	Tubeless Truck Valve TR573 With 25°
EX - 1296F	Tubeless Truck - TR573
EX - 1296F - 25	TR573 Truck Valve With 25°
EX - 1296F - 90	TR573 Truck Valve With 90°
573 - 100	Tubeless Truck - TR573



A - 573 - 100



TUBELESS TRUCK VALVES TR500 SERIES

Truck And Bus Tubeless Valve. Straight Clamp - In Type For Side Valve Holes On Demountable And Non - Demountable Rims With Standard 5/8" (.625") Valve Hole. High Quality Ozone Resistant Rubber Grommet Achieves Air - Tight Seal. TR# 574. Length 5" (127 mm)

Code	Description
A - 574 - 10	Tubeless Truck - TR574
EX - 1296G	Tubeless Truck - TR574



A - 574 - 10

AIR LIQUID VALVES AND ACCESSORIES

Standard Replacement Grommet For Agricultural TR - 618A Air Water Valves.

Code	Description
EXM - 272	Grommet - 618A Air Liquid Valve



EXM - 272

This Is The Replacement Grommet For TR - SP2 Large Bore Spuds. The Rubber Compound Includes High Heat Viton Within The Chemical Make - Up.

Code	Description
EXM - 165	Grommet For TR - SP - 2 - Viton



EXM - 165

Air Liquid Core Housing. New Style Fast Flow. Has O - Ring Seal. TR# CH - 3.

Code	Description
A - CH3	Air Liquid Core Housing - TRCH - 3
EX - 683A	Air Liquid Core Housing - TRCH - 3
6489A	Air Liquid Octagon Core House TRCH - 3



A - CH3

Air Liquid Core Housing. Old Style. TR# CH - 1

Code	Description
VH595	Air Liquid Core Housing - TRCH - 1
EX - CH - 1	Air Liquid Core Housing - TRCH - 1



VH595

Tubeless Air Liquid Valve For Tractor And Road Grader Service. For .625" Rim Hole. Bent Valve. Vertical Height 1 - 1/2" (38 mm). Angle Bend 65°. Horizontal Length 3" (76 mm). TR# 621A

Code	Description
A - 621A	Tubeless Air Liquid Valve - TR621A
EX - 679	Tubeless Air Liquid Valve - TR621A



A - 621A

Tubeless Air Liquid Valve For Tractor And Road Grader Service. For .625" Rim Hole. Bent Valve. Vertical Height 1 - 3/4" (44 mm). Angle Bend 90°. Horizontal Length 4 - 1/2" (114 mm). TR# 622A

Code	Description
A - 622A	Tubeless Air Liquid Valve - TR622A
EX - 672	Tubeless Air Liquid Valve - TR622A



A - 622A

Tubeless Air Liquid Valve For Tractor And Road Grader Service. For .625" Rim Hole. Bent Valve. Vertical Height 1 - 1/2" (38 mm). Angle Bend 65°. Horizontal Length 2 - 1/4" (57 mm). TR# 623A

Code	Description
A - 623A	Tubeless Air Liquid Valve - TR623A
EX - 678	Tubeless Air Liquid Valve - TR623A



A - 623A



AIR LIQUID VALVES AND ACCESSORIES

Tubeless Air Liquid Valve For Tractor And Road Grader Service. For .625" Rim Hole. Straight Valve. Vertical Height 1 - 7/8" (48 mm). TR# 618A

Code	Description
A - 618A	Tubeless Air Liquid Valve - TR618A
EX - 670	Tubeless Air Liquid Valve - TR618A
EX - 670R	Rubber Snap - In Base Agricultural - TR618A
A - 618RSI	Rubber Snap - In Base Agricultural - TR618A



A - 618A

Tubeless Front Tractor Air Liquid Valve. Low Profile Offers Minimum Protrusion Above Rim Hole. Effective Length 9/16" (14 mm). Fits .453" Rim Hole

Code	Description
VH936A	Tubeless Air Liquid - .453" - 9/16"
A - 936A	Tubeless Air Liquid - .453" - 9/16"
VH936 - 500	Tubeless Air Liquid - .453" And .625" 500/Box
TV - 6008C	Tubeless Air Liquid - Chrome 9/16" EFF
A - 936B	Tubeless Air Liquid - .625" - 9/16"
VH936B	Tubeless Air Liquid - .625" - 9/16"



VH936B



A - 936B

Air Liquid Extensions For Tubes. If Tube Is To Be Used In Tubeless Wheel, Remove Core Housing From Tube Valve And Transfer To Extension Before Assembly

Code	Description
302A	Air Liquid Tube Extension - Short
EX - 5905	Air Liquid Tube Extension - Long
301A	Air Liquid Tube Extension - Long



302A

Permits Fast Filling Of Tires With Fluid. Fits Most Tube And Tubeless Valves With Core Housing Removed. Extra Bushings For S.B. Valves And Old Style Valves. Side Button Valve Releases Air Displaced By Fluid. Connects To Standard 3/4" Garden Hose

Code	Description
VH598	Fluid Adapter Set



VH598

Plastic Nut For TR - 218A AND TR - 220A

Code	Description
A - 591	Air Liquid Nut - Plastic
EX - LN10	Air Liquid Nut - Plastic



EX - LN10

Brass Nut For TR - 218A And TR - 220A

Code	Description
A - 592	Air Liquid Nut - Brass
VH592	Air Liquid Nut - Brass
EX - 670W	Air Liquid Washer - EX - 670



VH592

**CHROME SLEEVE RUBBER SNAP - IN VALVES**

Standard Snap - In Passenger Tubeless Tire Valve For .453" Valve Hole. Fitted With An Attractive Hexagon Valve Cap And Chrome Sleeve To Cover Valve Stem Area. TR#413C. Length 1 - 1/4" (30 mm)

Code	Description
A - 413C	TR413 Standard Chrome Sleeve With Cap
A - 413CL	TR413 Long Chrome Sleeve With Cap
A - 412C	Snap - In Tubeless Valves - TR412C
2 - 427	TR413 Chrome Sleeve Short 100/Pack
A - 413CS - 100	TR413 Chrome Sleeve Long 100/Pack
A - 414C	Snap - In Tubeless Valves - TR414C
A - 418C	Snap - In Tubeless Valves - TR418C



A - 413C

ALUMINUM WHEEL TUBELESS TRUCK VALVES TR510 SERIES

Tubeless Valve Used In Drop - Center Aluminum Disc Wheels With 5/8" (.625") Bottom Valve Hole. TR# 511. 90° Angle Bend. Length 4 - 1/4" (108 mm)

Code	Description
A - 511 - 10	Tubeless Aluminum Wheel Valve - TR511
EX - 511	Tubeless Aluminum Wheel Valve - TR511
A - 509 - 10	Tubeless Aluminum Wheel Valve - TR509
VS - 946 - R	Tubeless Aluminum Wheel Valve - TR509
509 - 10	Tubeless Aluminum Wheel Valve - TR509
A - 510 - 10	Tubeless Aluminum Wheel Valve - TR510
EX - 513	Tubeless Truck Valve Low Height - TR513
EX - 515	Tubeless Truck Valve Low Height - TR515



A - 511 - 10

LARGE BORE VALVES AND ACCESSORIES

Large Bore Tubeless Tire Spud. Seals Into 13/16" Valve Hole To Accommodate Swivel Type Valve Stems.

Code	Description
A - SP2	Large Bore Tubeless Spud - Tire Spud - 2
EX - 1302	Large Bore Tubeless Spud - Tire Spud - 2
H - 41	Large Bore Tubeless Spud - Tire Spud - 2



A - SP2

Large Bore Double Spud

Code	Description
DS - 385	Large Bore Double Spud
EXC - 10	Large Bore Screw - In Tubeless Spud



EXC - 10

Agricultural Rim Hole Plug. Fits 5/8" Rim Hole.

Code	Description
A - 670P	Agricultural Tubeless Plug - 5/8"
P15	Rubber Rim Hole Plug - 5/8"
EX - 670P	Agricultural Tubeless Plug - 5/8"
N - 1012S	Agricultural Tubeless Plug - 5/8"
EX - 1300	Large Bore Rim Hole Plug - 13/16"



N - 1012S



LARGE BORE VALVES AND ACCESSORIES

Agricultural Rim Hole Plug. Fits 5/8" Rim Hole.

Code	Description
A - 670P	Rim Hole Plug 5/8"
P15	Rim Hole Plug 5/8"
EX - 670P	Rim Hole Plug 5/8"
N - 1012S	Rim Hole Plug 5/8"



A - 670P



N - 1012S



EX - 1300

Large Bore Rim Hole Plug - 13/16"

Code	Description
EX - 1300	Rim Hole Plug 13/16"

Large Bore Straight Valve TR - 670 - 2

Code	Description
EX - 3150/1	Large Bore Straight Valve TR - 670 - 2
EX - 670	Large Bore Straight Valve TR - 670 - 2



EX - 3150

Large Bore Straight Valve With Spud

Code	Description
EX - 3150	Large Bore Assembly - TR J - 670 - 2 And SP - 2
A - J653	Large Bore Swivel Valve - TRJ - 653
EXJ - 653	Large Bore Swivel Valve - TRJ - 653
EXJ - 40025	Large Bore Swivel Valve - TRJ - 4000 2 - 1/2"
A - J400025	Large Bore Swivel Valve - TRJ - 4000 2 - 1/2"
EXJ - 4003	Large Bore Swivel Valve - TRJ - 4000 3"
EXJ - 4002	Large Bore Swivel Valve - TRJ - 4000 2"
A - J669	Large Bore Swivel Valve - TRJ - 669
EXJ - 650	Large Bore Swivel Valve - TRJ - 650
A - J650	Large Bore Swivel Valve - TRJ - 650
EXJ - 654	Large Bore Swivel Valve - TRJ - 654
EXJ - 659	Large Bore Swivel Valve - TRJ - 659
EXJ - 655	Large Bore Swivel Valve - TRJ - 655
EXJ - 657	Large Bore Swivel Valve - TRJ - 657
EXJ - 4004	Large Bore Swivel Valve - TRJ - 4000 - 4
EXJ - 4004 - 74	Large Bore Swivel Valve 4" With 74°
EXJ - 4006 - 74	Large Bore Swivel Valve 6" With 74°
EXJ - 4008 - 74	Large Bore Swivel Valve 8" With 74°
EXJ - 40035	Large Bore Swivel Valve - TRJ - 4000 - 3.5



EXJ - 4003



EXJ - 650



EXJ - 654



EXJ - 40035



LARGE BORE VALVES AND ACCESSORIES

Large Bore Swivel Valve TRJ - 4000 - 5 90° Bend Effective Length 5"

Code	Description	Length
EXJ - 4005	Large Bore Swivel Valve - TRJ - 4000	5"
EXJ - 652	Large Bore Swivel Valve - TRJ - 652	5 - 1/2"
EXJ - 4006	Large Bore Swivel Valve - TRJ - 4000	6"
EXJ - 4007	Large Bore Swivel Valve - TRJ - 4000	7"
EXJ - 264 - 8214	Large Bore Swivel Valve - Cat Loader	72"
EXJ - 40075	Large Bore Swivel Valve - TRJ - 4000	7 - 1/2"
A - J400075	Large Bore Swivel Valve - TRJ - 4000	7 - 1/2"
EXJ - 4009	Large Bore Swivel Valve - TRJ - 4000	9"
EXJ - 4012	Large Bore Swivel Valve - TRJ - 4000	12"
EXJ - 4026	Large Bore Swivel Valve - TRJ - 4000	26"
EXJ - 4020	Large Bore Swivel Valve - TRJ - 4000	20"
EXJ - 4024	Large Bore Swivel Valve - TRJ - 4000	24"
EXJ - 4018	Large Bore Swivel Valve - TRJ - 4000	18"
EXJ - 4021	Large Bore Swivel Valve - TRJ - 4000	21"
EXJ - 4036	Large Bore Swivel Valve - TRJ - 4000	36"
EXJ - 40045	Large Bore Swivel Valve - TRJ - 4000	4 - 1/2"
A - J400045	Large Bore Swivel. Valve - TRJ - 4000	4 - 1/2"
EXJ - 651	Large Bore Swivel Valve - TRJ - 651	
A - J651	Large Bore Swivel Valve - TRJ - 651	
H - 816	70MS - 7 Aluminum Valve - Grommet	
WH - 45 - 2 - 1/2	Large Bore Swivel Valve J - 4000	2 - 1/2"



EXJ - 40045



A - J651



EXJ - 4005



EXJ - 4006



EXJ - 4009

Large Bore Valve Adaptor. Fits TR - 218A And TR - 220A Valves To Allow Use Of Valve In The 13/16" Valve Hole. TR# B9A

Code	Description
VHB9A	Large Bore Valve Adaptor - TRB9A



VHB9A

Large Bore Swivel Valve Adaptor Converts Tubes With SP - 1000 Type Spud To Accept Large Bore Swivel Valves. TR# AD4

Code	Description
EXH - 4000	Swivel Valve Adapter - TRAD4
EXH - 4000/1	Swivel Valve Adapter No Washer



EXH - 4000

Turret Valve Assembly TRJ - 690

Code	Description
EXJ - 690	Turret Valve - TRJ - 690
EXJ - 690B	Turret Valve - TRJ - 690 3 - 3/4"
EXJ - 690B3A	Turret Valve - Large Bore High Profile
EXJ - 691	Large Bore Turret Valve - TRJ - 691
EXJ - 691B	Turret Valve - TRJ - 691B
EXJ - 692	Turret Valve - TRJ - 692
EXJ - 694	Turret Valve - TRJ - 694
EXJ - 695	Turret Valve - TRJ - 695
EXJ - 697	Turret Valve - Extra Large Bore



EXJ - 690



EXJ - 690B



EXJ - 692

**LARGE BORE VALVES AND ACCESSORIES***Large Bore Screw - On Replacement Repair Valve For Tubes.*

Code	Description
EX - 1273	Large Bore Screw - On Valve - J - 1175C
EX - 1270	Large Bore Screw - On Valve - J - 1014
EX - 1268	Large Bore Screw - On Valve - J - 1076A
EX - 1265	Large Bore Screw - On Valve - J - 1078C
EX - 1276	Large Bore Screw - On Valve - J - 1179B
A - C2	Large Bore Core Short Brass - TRC - 2



EX - 1273



EX - 1270



EX - 1265



A - 417



A - 523MS

METAL CLAMP - IN VALVES*Clamp - In Tubeless Tire Valve For Passenger, Light Truck And Industrial Rims. Rubber Grommet Forms Seal.*

Code	Description
A - 416	TR416 Reg 1 - 1/4" - .453" And .625"
VS - 902 - CR	Spec Valve - TR416 - .453" And .625"
A - 416L	TR416 Long 2" - .453" And .625"
A - 523MS	Low Profile Clamp - In Valve
A - 523MS - HN	Low Profile Valve - Hex Nut
A - 417	Specialty Tire Valve - TR417
A - 501 - OV	Specialty Valve - Oval Hole



EX - 8800

TUBELESS TRUCK VALVES LOW PROFILE*V3 - 12 - 1 Low Height Euro Valve, Fits 5/8" (.625) Valve Hole Length 1 - 9/16"*

Code	Description
EX - 8800	V3 - 12 - 1 Low Height Euro Bus Valve
EX - 8845	Michelin 808 Valve (V3 - 14 - 2)



EX - 8845

SUPER LARGE BORE CORES AND SPUDS*Super Large Bore Spud. Fits 13/16" Rim Hole. TR# SP - 8*

Code	Description
EXR - 625	Super Large Bore Straight Valve - TRCH - 16
EXR - 626	Super Large Bore Valve And Spud - TR (CH - 16AND SP - 8)
EXR - 520	Super Large Bore Straight Valve - TR CH - 8
R - 520	Super Large Bore Straight Valve - TR CH - 8
PT - GAUGE	Haltec PT Gauge With Nut



EXR - 520

HIGH PRESSURE RUBBER SNAP - IN VALVES*Hp Tubeless Snap - In Valve For Use Up To 100 Psi. Max. Pressure, TR# 600HP 1.27" (32 mm)*

Code	Description
A - 600HP	Specialty Valve - TR600HP
600HP	Specialty Valve - TR600HP
A - 600HPC	High Pressure Snap - In With Chrome Sleeve
A - 801HP	Specialty Valve - TR801HP
A - 602HP	Specialty Valve - TR602HP
H - 2755 - L	Large High Pressure Connect 3000 3/8" - 24



A - 600HP



A - 801HP

CLAMP - IN TUBELESS TRUCK VALVES TR540 SERIES

O - Ring Seal Valve - TR542

Code	Description
VS - 542	O - Ring Seal Valve - TR542
TV - 542	O - Ring Seal Valve - TR542
A - 543 - 10	O - Ring Seal Valve - TR543
A - 543D - 10	O - Ring Seal Valve - TR543D
H - 543C	O - Ring Seal Valve - TR543C
A - 544 - 10	O - Ring Seal Valve - TR544
TV - 544C	O - Ring Seal Valve - TR544C
A - 544D - 10	O - Ring Seal Valve - TR544D
A - 544E - 10	O - Ring Seal Valve - TR544E
A - 545 - 10	O - Ring Seal Valve - TR545
VS - 545 - B	O - Ring Seal Valve - TR545B
VS - 545 - C	O - Ring Seal Valve - TR545C
A - 54536 - 10	O - Ring Seal Valve - TR545 - 36
A - 545D - 10	O - Ring Seal Valve - TR545D
545 - D	O - Ring Seal Valve - TR545D
VS - 545 - D	O - Ring Seal Valve - TR545D
A - 545E - 10	O - Ring Seal Valve - TR545E
VS - 546 - G	O - Ring Seal Valve - TR546G
A - 546D - 10	O - Ring Seal Valve - TR546D
VS - 546 - D	O - Ring Seal Valve - TR546D
TV - 546E	O - Ring Seal Valve - TR546E
VS - 546 - E	O - Ring Seal Valve - TR546E
A - 547D - 10	O - Ring Seal Valve - TR547D
TV - 547D	O - Ring Seal Valve - TR547D

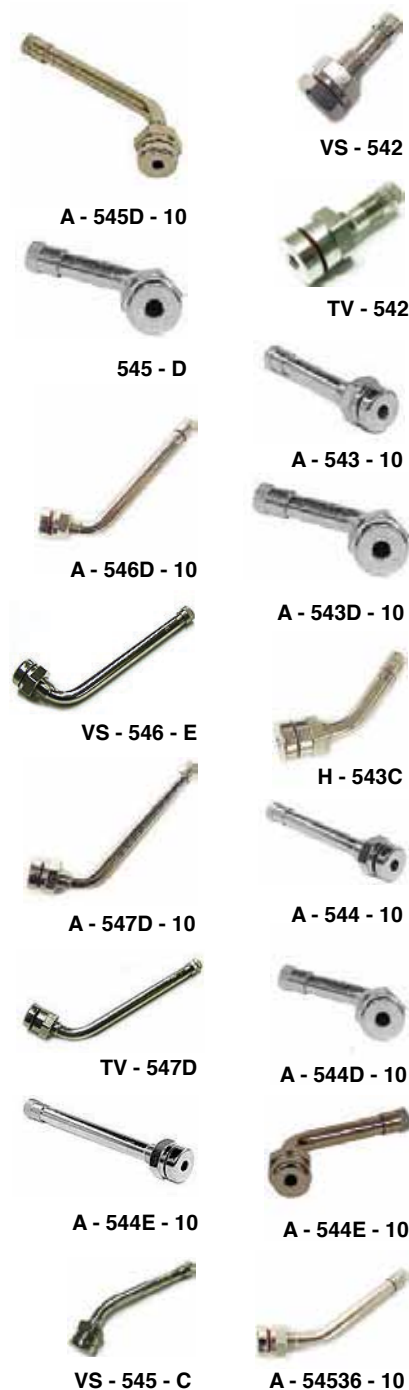

**AIR LIQUID CORE EJECTORS AND PARTS**

Valve Adapter Gun. Has 1/2" Female N.P.T. And Attaches To Any Calcium Tire Filling Pump. Extracts Valve Core From Standard Bore Valve Or Core Housing From Tractor Valve. Securely Holds Core Or Housing In Gun Body During Filling Or Evacuation Of Liquid

Code	Description
310H	Haltec Air Liquid Core Ejector
EX - 700	Exactra Air Liquid Core Ejector
FP - 146	Teflon Gasket
FP - 138	Ejector Union
FP - 134	Large Bore Core Remover
FP - 137	Standard Bore Valve Core Remover
FP - 143	O - Ring For FP - 142
FP - 135	Adapter For Standard Bore Valve
FP - 140	Stem And Chuck For 310H Unit
FP - 136	O - Ring For FP - 135
FP - 139	Rubber Gasket
FP - 142	Stem Sealing Union
FP - 144	Hand Wheel
FP - 145	Lock Nut For 310H



EX - 700



FP - 138

MOTORCYCLE VALVES

Code	Description
A - 430A	Clamp - In Motorcycle Valve .327 RH
A - 401HP	Hi - Pressure Motorcycle Valve 8.8 mm RH
A - 412B	TR412 Snap - In With 90° Brass



A - 430A



A - 401HP

CLAMP - IN TUBELESS TRUCK VALVES TR550 SERIES

Code	Description
VS - 552	Dill Alcoa Valve - 550 Series
A - 552 - 10	Alcoa 550 Service Valve - Straight
VS - 553	Dill Alcoa Valve - 550 Series
A - 553 - 10	Alcoa 550 Service Valve - Straight
VS - 553 - C	Dill Alcoa Valve - 550 Series
A - 553C - 10	Alcoa 550 Service Valve - 45D Bend
A - 553D - 10	Alcoa 550 Service Valve - 60D Bend
VS - 553 - E	Dill Alcoa Valve - 550 Series
A - 553E - 10	Alcoa 550 Service Valve - 75D Bend
A - 554C - 10	Alcoa 550 Service Valve - 45D Bend
VS - 554 - D	Dill Alcoa Valve - 550 Series
A - 554D - 10	Alcoa 550 Service Valve - 60D Bend
VS - 555 - D	Dill Alcoa Valve - 550 Series
A - 555D - 10	Alcoa 550 Service Valve - 60D Bend
VS - 555 - E	Dill Alcoa Valve - 550 Series
A - 555E - 10	Alcoa 550 Service Valve - 75D Bend



VS - 552

VS - 553
- C



TANK VALVES

Tank Valve For Charging Pressure Tanks Or Compressed Air Chambers. Tank Valves Are Used With Various Gases, Fluids And Operating Pressures. Complete With Core And Cap. Has 1/4" Male N.P.T.

Code	Description
EX - 6047	Tank Valve - TRJ - 671
02500	Tank Valve - 1/8 N.P.T. - Length 3/4"
645L - 6	Tank Valve - 1 - 5/16" 1/8" N.P.T.
9166L - 8	Tank Valve - 27/32". 1/8" N.P.T.
02529	Tank Valve - 1/4" N.P.T. - Length 7/16"
TV - 400	Tank Valve 1 - 5/16" Oal 1/4" N.P.T.
TV - 401	Tank Valve 27/32" 1/8" N.P.T



VS - 554 - D



EX - 6047

RACING AND CUSTOM WHEEL VALVES

Enki Valve Straight . Effective These Are Great If You Are Working With Aftermarket Rims With Recessed Valve Holes. Sometimes The Body Of The Premier VS8 Is Too Thick But The Haltec VS8 Will Fit.

Code	Description
A - VS8	Enki Valve Straight 1 - 1/2"
TV - 6010	Enki Valve Straight Effective Length 3/4"
A - VS8L	Enki Valve Straight 2 - 1/4"
EX - 1296Z1	Enki Valve Straight Effective 1 - 1/4"
A - VS8 - 6MM	Enki Valve For 6 mm Rim Hole
A - VS8D45	Enki Valve With 45° Bend
A - VS8D90	Enki Valve W / 90° Bend
WA4525	Flush Mount Stem 11.3 mm RH 4 Pack
WA4525 - EXT	Flush Mount - Inflator Extension Only



02500



A - VS8

SPECIALTY VALVES

Metric Rim Hole O - Ring Seal Valve. Some Imported Trucks Will Have Steel Wheels That Incorporate A .389 Valve Hole.

Code	Description
A - V3 - 20 - 1	T.L. Truck .389 - Straight - 1 - 1/2"
A - V3 - 20 - 5	T.L. Truck .389 - Bent - 1+1 - 9/16"
A - V3 - 20 - 4	T.L. Truck .389 - Bent - 1+2 - 3/8"
A - V3 - 20 - 6	T.L. Truck .389 - Bent - 1+3 - 11/32"



A - VS8D90



A - V3 - 20 - 1

**LARGE BORE RIGID EXTENSION***Large Bore Straight Rigid Metal Extension.*

Code	Description	Length
EX - 2018	Large Bore Metal Ext Rigid	18"
EX - 2003	Large Bore Metal Ext Rigid	3"
EX - 2006	Large Bore Metal Ext Rigid	6"
EX - 2004	Large Bore Metal Ext Rigid	4"
EX - 201075	Large Bore Metal Ext Rigid	10 - 3/4"
EX - 2010	Large Bore Metal Ext Rigid	10"
EX - 20015	Large Bore Metal Ext Rigid	1 - 1/2"
EX - 2008	Large Bore Metal Ext Rigid	8"
EX - 2012	Large Bore Metal Ext Rigid	12"
EX - 2002	Large Bore Metal Ext Rigid	2"
EX - 20025	Large Bore Metal Ext Rigid	2 - 1/2"
EX - 2005	Large Bore Metal Ext Rigid	5"
EX - 2007	Large Bore Metal Ext Rigid	7"
EX - 2009	Large Bore Metal Ext Rigid	9"



EX - 2003



EX - 2004



EX - 2005



A - 50023



A - EV42NI - N



A - BLV302



EX - 1298C



60MS - 27



70MS - 7

SPECIAL APPLICATION VALVES

Code	Description
A - 50023	23° Clamp - In For .625" Hole
EX - 1223R	23° Clamp - In For .625" Hole
N - 1147	23° Clamp - In For .625" Hole
A - EV42NI - N	High Performance 42 mm L - 11 mm X 16 mm HX NU
VS - 943 - R	Specialty Application 21° Type Truck Valve
A - BLV302	Euro Style Bus Valve - 3"
A - BLV303	Euro Style Bus Valve - 3 - 1/2"
EX - 1298C	3 - 1/8" Or Bus/Truck Valve - Straight.
EX - 1298C - 13	3 - 1/8" Or Bus/Truck Valve With 13°
EX - 1298C - 30	3 - 1/8" Or Bus/Truck Valve With 30°
EX - 1298E	3 - 3/4" Or Bus/Truck Valve - Start
VS - 938F	16" X 6" Accuride Steel - Nickel
VS - 944F	16" X 7" Accuride Steel - Chrome
VS - 902WP	Ford F - Series Outer Dual Valve Aluminum
VS - 902K	Ford F - Series Outer Dual Valve Steel
VS - 962C	Ford F - Series Inner Dual Valve
TV - 416MC	Ford F - Series Inner Dual Valve
N - 1600CC	Ford F - Series Dual Valve
A - BLV421 - 2	Ford F - Series Chrome Outer Valve
A - 412L	Tr412 Snap - In With 90° Brass
A - V2 - 04 - 1	High Performance Euro Valve Specialty Base
A - V3 - 14 - 3	Euro Truck/Bus Low Clearance Valve
A - 60MS9727	Specialty Mich Valve 60MS 9.7 - 27
60MS - 27	Specialty Mich Valve 60MS 9.7 - 27
70MS - 27	Specialty Mich Valve 70MS 9.7 - 27
90MS - 27	Specialty Mich Valve 90MS 9.7 - 27
A - BL39MS83	High Performance Combo Valve 8.3 RH
70MS - 7	Specialty Mich Valve 70MS 9.7 - 7

**MICHELIN REPLACEMENT VALVES***Screw - On Repair Valve For Truck And Bus, Tube - Type Tires. Quick Replacement For Broken Tube Valves With Body Thread.*

Code	Description
A - 4567	Michelin Replacement Valve Single Bend 5"
EX - 1292AA	Michelin Replacement Valve Single Bend 1 - 7/8"
EX - 1292A	Michelin Replacement Valve Single Bend 2 - 1/2"
EX - 1292B	Michelin Replacement Valve Single Bend 3"
EX - 1292E	Michelin Replacement Valve Single Bend 5"
EX - 1292R	Michelin Replacement Valve Double Bend 3 - 3/4"
EX - 1292N	Michelin Replacement Valve Double Bend 5"
EX - 1293N	Michelin Replacement Valve Triple Bend
A - 1075A	Metal Replacement Valve - TR1075A
A - 1175A	Metal Replacement Valve - TR1175A
A - 1078A	Metal Replacement Valve - TR1078A



A - 4567



EX - 1292N



A - 1075A

LARGE BORE BENDABLE EXTENSIONS*Large Bore Rigid, Light - Weight Hand - Bendable Valve Extension. Have Protective Braided Cover.*

Code	Description
EX - 3030	Large Bore Bendable Extension Effective Length 30"
EX - 3018	Large Bore Bendable Extension Effective Length 18"
EX - 3006	Large Bore Bendable Extension Effective Length 6"



EX - 3030

PLASTIC VALVE EXTENSIONS

Code	Description
685 - P - 50	Dill Valve Extension 1/2"
A - 34 - 100	Plastic Nylon Extension 3/4"
686 - P - 50	Dill Valve Extension 3/4"
687 - P - 50	Dill Valve Extension 1"
A - 35 - 100	Plastic Valve Extension 1 - 1/4"
688 - P - 50	Dill Valve Extension 1 - 1/4"
689 - P - 50	Dill Valve Extension 1 - 1/2"



685 - P - 50



A - 34 - 100

GROMMETS

Code	Description
A - B6 - 50	Plastic Rim Hole Bushing .625" To .453" TR# B6
A - RG46	Replacement Rubber Grommet For TR509,TR510,TR511.
A - RG15	Replacment Rubber Grommet For TR570 Series Truck Valves.
462F	High Temperature Replacment Rubber Grommet For TR570 Series Truck Valves.
G - 170S	High Temperature Replacment Rubber Grommet For TR570 Series Truck Valves.
EX - 570W	TR570 Series Washer
EX - 570N	TR570 Series Nut
VH824	Replacment Grommet For Michelin Screw - On Replacment Valves.
8808A	Michelin Reducer Bushing To Standard Valve Thread.
A - RG60	O - Ring For Alcoa Style TR540 Series Valves.
EX - 116V	Viton O - Ring For Euro Truck Valves.
568 - 011G	Green O - Ring For Nitro.
885	Dill Green O - Ring For Nitro.
A - RG70	Grommet For TR - 550 Series Alcoa Type Valves.
A - RG54	TR416 - Replacement Grommet .453"
A - RG39	TR416 - Replacement Grommet .625"
RG - 70	Grommet For TR - 550 Series Alcoa Type Valves.



A - B6 - 50



462F



G - 170S



LARGE BORE VALVE TOOLS

Code	Description
VH65558	Large Bore To Standard Bore Adapter Trad - 1
A - 65658	Large Bore To Standard Bore Adapter Trad - 1
EX - 1285	Large Bore To Standard Bore Adapter Trad - 1
VH65658	Large Bore To Standard Bore Adapter Trad - 1
A - 675	Screw Drive Core Tool Large And Standard Bore
EX - 685	Screw Drive Core Tool Large And Standard Bore
VH675	Screw Drive Core Tool Large And Standard Bore
EX - 1019	Large Bore Valve Core Tool
EX - 1017	Large Bore Valve Long Core Tool
EX - 1016	Large Bore Valve Core Tool
5265	Large Bore Valve Core Tool
5267	Dill Large Bore Core Extractor
N - 1910	Large Bore Valve Core Tool
5260	8 - Piece Large Bore Valve Tool Kit
EX - 1200K	8 - Piece Large Bore Valve Tool Kit With Digital Gauge
EX - 1200K - 2	8 - Piece Large Bore Valve Tool Kit With Prec. Gauge
EX - 1018L	Large Bore Hex Cap Tool
TL - LN - 10	Nut Driver For LN - 10 Nut On TR218A
EX - 609LB	Large Bore Chain Fishing Tool
ASP - 10	Large Bore Tube Deflator
EX - 4660 - A	Large Bore Clip - On Air Chuck
322	Large Bore Dual Foot Chuck
562 - 5088	Large Bore Euro Style Clip - On Chuck
VHJ6105	Large Bore Clip On Air Chuck
10013	Large Bore Screw - On Air Chuck
2 - 6105	Large Bore Clip - On Air Chuck Closed
EX - 1021	Large Bore Core Extractor
A - J608	4 Way - Large Bore Core Tool
EX - 1522	4 Way - Large Bore Core Tool
TL - 695	4 Way - Large Bore Core Tool
EX - 1525	4 Way - Large Bore Core Tool
EX - 990	Super Large Bore Assembly Tool



EX - 1284



N - 1510



EX - AD

- 1



A - 675



5260



EX - 1018L



322



2 - 6105



A - J608



TL - 695

LARGE BORE VALVE CAPS

A - VC6	Large Bore Screw Driver Valve Cap TRC - 6
EX - 1281	Large Bore Screw Driver Valve Cap TRC - 6
EX - 1283	Large Bore Hex Driver Valve Cap TRC - 7
A - VC7	Large Bore Hex Driver Valve Cap TRC - 7
EX - 1287	Large Bore Dome Valve Cap TRC - 7
EX - 1284	Large Bore Valve Cap Remover
EX - 1375	Plastic Valve Caps Black 100/Pack
N - 1510	Large Bore Cap Gauge
A - AD1	Large Bore To Standard Bore Adapter Trad - 1
EX - AD - 1	Large Bore To Standard Bore Adapter Trad - 1

**METAL VALVE EXTENSIONS**

Code Description

VH601 Metal Valve Extension 1/2"

EX - 1510 Metal Valve Extension 5/8"

VH602 Metal Valve Extension 3/4"

A - 602 Metal Valve Extension 3/4"

VH603 Metal Valve Extension 1 - 1/4"

EX - 1512 Metal Valve Extension 1 - 1/4"



VH601



VH603

TRUCK VALVE EXTENSIONS

Code Description

7744 1" Truck Standard Metal Valve Extension

HE - 369 1 - 3/8" Truck Extension Sht.Collar - Lightweight

356 1 - 3/8" Truck Extension Sht.Collar - Lightweight

A - EXT40 Truck Straight Metal Extension - 1 - 5/8"

EX - 1500L Truck Straight Metal Extension - 2"

HE - 370 2" Truck Extension Sht.Collar - Lightweight

A - EXT60 Truck Straight Metal Extension - 2 - 3/8"

331 3" Truck Extension Sht.Collar - Lightweight

EX - 1501 Truck Straight Metal Extension 3 - 1/16"

A - EXT84 Truck Straight Metal Extension 3 - 3/8"

EX - 1503 Truck Straight Metal Extension 3 - 5/8"

EX - 1504 Truck Straight Metal Extension 4"

EX - 1504L Truck Straight Metal Extension 4"

HE - 4430 4" Truck Extension Large Collar - Lightweight

HE - 351 Truck Extension - 3.82". Black Pol.

A - EXT125 Truck Straight Metal Extension 4 - 7/8"

EX - 1502 Truck Straight Metal Extension 5 - 1/16"

HE - 352 Truck Extension - 5.21" Black Pol.

A - EXT142 Truck Straight Metal Extension - 5 - 5/8"

EX - 1506 Truck Straight Metal Extension - 6"

EX - 1506L Truck Straight Metal Extension - 6"

7383 Truck Straight Metal Extension - 6 - 1/16"

HE - 392 5 - 1/8" Truck Extension Large Collar - Lightweight

HE - 393 6" Truck Extension Large Collar - Lightweight

HE - 394 8" Truck Extension Large Collar - Lightweight

HE - 395 10" Truck Extension Large Collar - Lightweight

317 - 10 10" Truck Extension Large Collar

317 - 11 - 3/4 11 - 3/4" Truck Extension Large Collar

HE - 396 12" Truck Extension Large Collar - Lightweight

HE - 200 Standard Bore Bent Extension - 90°

A - EXT40 - 90D Standard Bore Bent Extension - 90° 40 mm

HE - 201 Standard Bore Bent Extension - 45°

HE - 202 Standard Bore Bent Extension - 135°

HE - 204 Standard Bore Bent Extension - 180°

HE - 391 2 - 15/16" Truck Extension Collar - Large Weight



7744



331



A - EXT84



7383



HE - 393



HE - 200



**SUPER LARGE BORE VALVES AND ACCESSORIES**

Code	Description
EXR - 764R	Super Large Bore Tubing Connector Sleeve
EXR - 521	Super Large Bore Core Housing
EXC - 200	Super Large Bore Screw - In Spud
EXMR - 800 - 925	Super Large Bore Rigid Valve 90 Deg. Bend Effective Length 9 - 1/4"
EXB - 222	Super Large Bore Lock - On Nut For Exm - 3000 - 8



EXR - 521

FLEXIBLE RUBBER VALVE EXTENSIONS

Code	Description
FE - 300 - 5	Dual Wheel Flexible Valve Extension 5"
FE - 300 - 7	Dual Wheel Flexible Valve Extension 7"
2 - 300 - 7	Dual Wheel Flexible Valve Extension 7"
FE - 300 - 9	Dual Wheel Flexible Valve Extension 9"
FE - 300 - 11	Dual Wheel Flexible Valve Extension 11"
FE - 300 - 36	Dual Wheel Flexible Valve Extension 36"



FE - 300 - 5

ALCOA VALVE EXTENSION STABILIZER*Alcoa Valve Stabilizers. Fits Alcoa Wheels*

Code	Description
H - 2125	Alcoa Valve Stabilizer 1.50" Center
H - 2126	Alcoa Valve Stabilizer 1.50" Off Center
H - 2127	Alcoa Valve Stabilizer 1.50" Center
H - 2225	Alcoa Valve Stabilizer 2" Center
H - 2245	Alcoa Valve Stabilizer 2.19" Center
H - 2246	Alcoa Valve Stabilizer Oval For Peterbilt
H - 2227	Alcoa Valve Stabilizer 2.50" Center
H - 2247	Alcoa Valve Stabilizer Off Center 2.375" Center



FE - 300 - 7



2 - 300 - 7



H - 2127



H - 2246

OTR SPECIAL APPLICATION VALVES

Code	Description
EX - 117 - 0764	CAT Valve 7" Cat - 980D
EX - 146 - 6779	CAT Valve 6 - 1/8" CAT - 980G
EX - 144 - 0290	CAT Valve 7 - 7/8" CAT - 988G
EXC - 100	Super Large Bore Screw - In Spud TR - SP9
EX - 789 - O	Super Large Bore Special Formed Rigid Valve
EX - 777 - BO	Super Large Bore Special Formed Rigid Valve
EXMR - 850 - 8	Super Large Bore Rigid Valve 90° Bend Effective Length 8"
EXMR - 890 - 6	Super Large Bore Turret Valve Effective 6"
EXMR - 890 - 8	Super Large Bore Turret Valve Effective 8"
EXMR - 890 - 10	Super Large Bore Turret Valve Effective 10"
SXL - 1008L	Super XLarge Rim Spud Long Oval 1.55"
SXL - 1660 - 50	Super XLarge 50" Flex Assembly
EXG - 8019VC	Super Large Bore Special Formed Valve 1 Bend 8"
EXG - 4985VC	Super Large Bore Special Formed Valve 4 Bends 19.75"
EX - 1280A	Large Bore Core Short - TRC - 2
EXG - 8018VC	Large Bore Special Form Valve 4 - Bends 26 - 3/4"
EXD - 7103EC	Large Bore Special Form Valve 4 - Bends 16 - 1/4"



EX - 117 - 0764



EX - 144 - 0290



EX - 990



EXG - 8019VC

**FLEXIBLE METAL BRAIDED VALVE EXTENSIONS**

Dual Wheel Flexible Valve Extension With Steel Braided Hose. Provides Easy Access To Inner Dual Tire On Campers, Rec Vehicles And Lt Trks. Fits Std Valve Cap Threads.

Code	Description
SFE - 400 - 5	Steel Braided Flexible Extension 5"
SFE - 400 - 7	Steel Braided Flexible Extension 7"
2 - 400 - 7	Steel Braided Flex Extension 7"
SFE - 400 - 10	Steel Braided Flexible Extension 10"
22 - 604	Steel Braided Flex Extension 13 - 1/2"
SFE - 400 - 13180	Steel Braided Flexible Extension 13 - 1/2" With 180° Fit
EX - 1407	Steel Braided Flexible Extension 7"
EX - 1407 - 90	Steel Braided Flexible Extension 7" With 90° Fit
EX - 1407 - 180	Steel Braided Flexible Extension 7" With 180° Fit
EX - 1410	Steel Braided Flexible Extension 10"
EX - 1410 - 90	Steel Braided Flexible Extension 10" With 90° Fit
EX - 1410 - 180	Steel Braided Flexible Extension 10" With 180° Fit
EX - 1412	Steel Braided Flexible Extension 12"
EX - 1412 - 90	Steel Braided Flexible Extension 12" With 90° Fit
EX - 1412 - 180	Steel Braided Flexible Extension 12" With 180° Fit
EX - 1414	Steel Braided Flexible Extension 14"
EX - 1414 - 90	Steel Braided Flexible Extension 14" With 90° Fit
EX - 1414 - 180	Steel Braided Flexible Extension 14" With 180° Fit



SFE - 400 - 5



2 - 400 - 7



22 - 604

AIR - FLEXX FLEXIBLE EXTENSIONS

Non - Pressurized And Unbreakable Valve Extension. Length Is From The Base To The End Of The Thread.

Code	Description
AFX - 75Y	Air - Flexx Valve Extension 75 mm (2.95")
AFX - 75B	Air - Flexx Valve Extension 75 mm (2.95")
AFX - 85Y	Air - Flexx Valve Extension 85 mm (3.35")
AFX - 85B	Air - Flexx Valve Extension 85 mm (3.35")
AFX - 105Y	Air - Flexx Valve Extension 105 mm (4.13")
AFX - 105B	Air - Flexx Valve Extension 105 mm (4.13")
AFX - 145Y	Air - Flexx Valve Extension 145 mm (5.71")
AFX - 145B	Air - Flexx Valve Extension 145 mm (5.71")
AFX - 185Y	Air - Flexx Valve Extension 185 mm (7.28")
AFX - 185B	Air - Flexx Valve Extension 185 mm (7.28")
AFX - 215Y	Air - Flexx Valve Extension 215 mm (8.47")
AFX - 215B	Air - Flexx Valve Extension 215 mm (8.47")
AFX - 315Y	Air - Flexx Valve Extension 315 mm (12.4")
AFX - 415Y	Air - Flexx Valve Extension 415 mm (16.34")



AFX - 75Y



AFX - 75B



AFX - 85Y

TRUCK VALVE CAPS

Code	Description
VH54HT - 1	Metal Cap H.D. Heat Resist.
EX - 1312	Metal Standard Bore Heavy Duty Cap 100 Bag
7612	Heavy Duty Hex Cap - High Heat 100 Pack
6541 - N	Metal Double Seal Valve Cap
1046	Metal Double Seal Valve Cap - USA Made
33 - 0709	V2B Alligator Double Seal Cap
DS-1	HALTEC Metal Double Seal Valve Cap



VH54HT - 1



33 - 0709

**PLASTIC VALVE CAPS**

Code	Description
A - VC8 - 100	Plastic Valve Caps Black 100/Pack
A - VC8 - S - 100	Plastic Caps - Sealing - 100/Box
A - VC8G - S - 100	Plastic Green Cap W/Seal 100/Bag
BLVC22 - PINK	Plastic Valve Cap Pink W/Seal 100/Bag
627 - 500/BOX	Plastic Valve Caps Black 500/Box
A - VC8G - 100	Plastic Valve Caps Green 100/Pack
VC8G - 100	Green Plastic Seal Valve Cap 100/Pack
VC8G - 1000BK	Green Plastic Seal Valve Cap 1000/Box
CAB - VC8R - 100	Counteract Red Valve Cap 100/Bag
5620313	Plastic Valve Caps Green 100/Pack
690	Anodized Plastic N2 Cap 100/Pack
680	Chromed Alum Nitro Cap 100/Pack
897 - 100/BOX	Dill Green Plastic N2 Cap 100/Pack



A - VC8 - 100



A - VC8 - S - 100



690



680



A - C1 - HT - 100



MICH - C1HT - 100



A - C1 - LF - 20



A - VC12 - 100



A - VC13 - 100



A - VC14 - 100



89 - GCAP - 100

TRUCK VALVE CORES

Code	Description
A - C1 - HT - 100	Heat Resistant Core Brass
MICH - C1HT - 100	MichelinType Short Valve Core 100/Pack
402 - AH - 100	Stand Valve Core C4 - Aircraft 100/Pack
A - C1 - HT - 100 - N	Heat Resistant Core Nickel
A - C1 - HT - L100N	Long Valve Core Heat Nickel 100/Pack
A - C1 - LF - 20	Large Filtered Valve Core (20/Pack)

METAL VALVE CAPS

Code	Description
A - VC12 - 100	Chromed Hex Dome Cap - TRVC12
A - VC13 - 100	Chrome Hex Cap - TRVC - 13
A - VC14 - 100	Chrome Hex Dome Cap - TRVC - 14
A - VC15 - 100	Chrome Hex Cap - TRVC - 15
89 - GCAP - 100	Green Dot Chrome Cap 100/Pack
A - VC42G - 20	Colour Aluminum Valve Cap - Green 20/Pack
EX - 1365	Metal Dome Cap - TRC - 3 100/Pack
EX - 1360	Chrome Hex Cap - TRVC - 13 100/Pack

VALVE SERVICE TOOLS

Code	Description
2 - 296	2 - Way Valve Repair Tool
6129	E - Z Out Core Tool
A - 605 - N	4 - Way Tool - Nickel Plated
TVT	4 - Way Tool - Nickel Plated
A - 605 - BH	4 - Way Tool - Black Hardened
VH608	4 - Way Tool Heavy Duty - Ken-Tool T16P
VH673	Screwdriver Tool
EX - 1616	Screwdriver Tool
A - 673	Screwdriver Tool - Red
5411	Screwdriver Tool
TL - 132	Shur - Lock Standard Valve Core Tool
TL - 133	Shur - Lock Standard XL Valve Core Tool
A - 673LK	Quik - Lock Standard Valve Core Tool
VH674	Hex Tool
2688	Metal Core Extracting Tool
A - 673L	Extra Long Valve Core Tool - Red
VH680	Extra Long Valve Core Tool
VH679	Recessed Tool
VH670	Valve Cap Tool - Knurled
VALVECAPPER	Cap/Core Removal Tool 11 - 1/2"
VSW - 916	Valve Nut Ratchet - 570 Series
168 - 01942	9/16" Valve Nut Torque Wrench
168 - 10100	5/8" Valve Nut Torque Wrench
168 - 10042	9/16" And 5/8" Torque Wrench Kit
VH678	Hex Nut Driver Standard Bore
A - 678	Hex Nut Driver - TR500 Series
TL - 632	Truck Extension Tightner
2 - 306	Cable Fishing Tool - S.B.
2 - 606	Cable Fishing Tool - S.B.
2 - 306L	Cable Fishing Tool X - Long 24"
VH607	TI - 650 Chain Fish Tool - Standard
EX - 609	Chain Fishing Tool - Standard Bore
8909	Valve Fishing Tool
2 - 303	Tube Deflator Single Piece
VH3216	Tube Deflator Heavy Duty
EXLT - 03	Standard Bore Heavy Duty Tube Deflator



6129

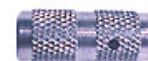

2 - 296



TVT



A - 605 - N



VH608



A - 605 - BH



VH673



5411



EX - 1616



TL - 133



TL - 132



2688



A - 673LK



VH680

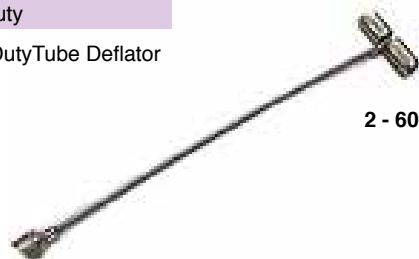

2 - 606



2 - 303



PASSENGER VALVE CORES

Standard Short Valve Cores.

Code	Description
A - C1 - 100	Short Core Brass - TRC - 1
A - C1 - 100 - N	Short Core Nickel - TRC - 1



A - C1 - 100 - N

PRESSURE EQUALLIZERS

Code	Description
1125 - 100	Visualizer 100 PSI With Hoses
1125 - 105	Visualizer 105 PSI With Hoses
1125 - 110	Visualizer 110 PSI With Hoses
1125 - 115	Visualizer 115 PSI With Hoses



1125 - 100

TUBE REPAIR VALVES

Code	Description
9 - 14	Passenger Valve
9T - LB	TR218 Air Liquid Tractor Valve
PTV	TR13 Tube Replacement Valve .453"



PTV

Got a question about a product?

Looking for something?

Contact Prema at 800.268.6311 or visit

www.premacanada.ca

for answers!



Counteract



Tire Balancing Beads

The only tire balancing product with patented electrostatic cling technology. Proven to improve fuel economy in two separate SAE and TMC Type II fuel tests.

All other methods that have tried have failed.



NEW!

Stud Cleaning Brush

Quickly and effectively removes rust and debris from wheel studs using your air wrench or handheld power drill (with adapter).

Brushes available for stud sizes:

- 12 mm
- 13 mm
- 14 mm
- 16 mm
- 22 mm





Air Tools And Accessories





1/4" IMPACT WRENCHES

1/4" Ratchet Wrench. Maximum Torque Of 20 Ft./Lbs. Large Bore. Extra Compact And Easy To Maintain

IR - 104B

1/4" Standard Ratchet Wrench



3/8" IMPACT WRENCHES

Maximum Impact. The New 2115TiMax Delivers Best In Class Performance For A Tool Less Than Six Inches Long And Weighing Less Than Two And A Half Pounds. The Minimal Size Of This Tool Will Allow Greater Access To Tight Spaces, While The Minimal Weight Will Reduce Operator Fatigue All While Still Delivering Maximum Performance. Titanium Hammer Case Is Lightweight With Unparalleled Durability. The Original, Perfected Twin Hammer Mechanism Utilizes Proprietary Advanced Metallurgy. Hard Coat Anodized End Plate Stands Up To The Toughest Jobs. Patented Four - Position Power Regulator Dial For Maximum Control. New 7 - Vane Motor Delivers Even More Power. Improved Grease Fitting For Easy Maintenance. Patented One - Hand Forward/ Reverse For Easy Operation. Feather - Touch Trigger Enables Impressive Control. New Ergonomic Housing Offers Greater Operator Comfort. Optimized Air Flow Ensures Maximum Performance. Maximum Power - 300 Ft - Lbs. Maximum Power In Reverse — That's Best In Class Power Performance. Maximum Control - Enhanced Power Settings, A Feather Touch Trigger And Patented Push Button Forward/Reverse Provide Maximum Control. Max Reliability - Free Two - Year Limited Warranty With Tool Registration.

IR - 2115TiMAX

3/8" TD Impact Wrench

IR - 2115QTiMAX

3/8" TD Impact Wrench - Quiet



1/2" IMPACT WRENCHES

Maximum Impact. As If The Ingersoll Rand 2135Ti Wasn't Already The Best 1/2" Air Impact Tool You Can Buy, We Decided To Make It Even Better. Perfect For Tackling Any Job In The Service Bay, The New 2135TiMax Delivers Maximum Power And Control, Along With Unmatched Reliability That Comes From More Than A Century Of Proven Engineering And Innovation. Titanium Hammer Case Is Lightweight With Unparalleled Durability. The Original, Perfected Twin Hammer Mechanism Utilizes Proprietary Advanced Metallurgy. Hard Coat Anodized End Plate Stands Up To The Toughest Jobs. Patented Four - Position Power Regulator Dial For Maximum Control. Patented One - Hand Forward / Reverse For Easy Operation. Optimized Air Flow Ensures Performance. Feather - Touch Trigger Enables Impressive Control Improved Grease Fitting For Easy Maintenance Maximum Power - 780 Ft - Lbs. Maximum Reverse Torque From A Tool Weighing Less Than 4 Lbs. — That's The Best Power - To - Weight Ratio In Its Class. Maximum Control - Feather - Touch Trigger, Wider Range Of Power Regulator Settings In Forward, Always Maximum Power In Reverse, Patented One Hand Forward / Reverse Control. Maximum Reliability - Free Two - Year Limited Warranty With Tool Registration.

IR - 2135TiMAX

1/2" Impact Wrench

IR - 2135QTiMAX

1/2" Impact Wrench - Quiet

IR - 2135Ti - 2MAX

1/2" Impact Wrench With 2" Extended Anvil

IR - 2135QTi - 2MX

1/2" Impact Wrench Quiet With 2" Extended Anvil



1/2" IMPACT WRENCHES

IR - 231HA

1/2" Standard Impact Wrench

IR - 231HA - 2

1/2" Standard Impact Wrench With 2" Extended Anvil



3/4" IMPACT WRENCHES

The Highly - Regarded 261 Model Combines Compact Size At Only 8.8" Long With High Output, Which Makes It Perfect For Everything From Spring Work To Pinion Nut And Track Pad Removal And Major Engine Teardowns. Features Jumbo Hammer Mechanism. 1,200 Ft - Lbs Of Maximum Torque. Pressure - Fed Lubricant System For Trouble - Free Performance And Longer Life.

IR - 261

3/4" Impact Wrench

IR - 261 - 6

3/4" Impact Wrench With 6" Extended Anvil

IR - 261 - 3

3/4" Impact Wrench With 3" Extended Anvil





3/4" IMPACT WRENCHES

New! 2145QiMax Impactool™ The New Ingersoll Rand 2145Qimax 3/4" Drive Impactool™ Delivers Incredible Performance And Industrial - Grade Durability In An Impact Wrench. Plus, Its Efficient Air Motor Reduces Air Consumption To Save You Money. Perfect For The Most Demanding Applications, Such As Truck And Bus Service, Construction And Agricultural equipment Maintenance, As Well As The Mro Market. Features And Benefits Max Power. 1350 Ft - Large Bore Maximum Reverse Torque From A Tool That Weighs Just 7.4 Large Bores And Is Compact Enough To Access Tight Spaces. Max Durability. Built To Last And Designed To Withstand Tough Use In Rugged Environments; A Two - Year Limited Warranty Is Standard. Maximum Productivity. An Air Motor That's 16% More Efficient Than Its Predecessor And An Easy - To - Clean Inlet Screen Means Less Downtime, Better Tool Performance And Less Money Spent On Compressed Air

IR - 2145QiMAX

3/4" Impact Wrench Heavy Duty - Quiet

IR - 2145QiMAX - 3

3/4" Impact Wrench Heavy Duty - Quiet
With 3" Extended Anvil

IR - 2145QiMAX - 6

3/4" Impact Wrench Heavy Duty - Quiet
With 6" Extended Anvil



1" IMPACT WRENCHES

The 285B Combines Exceptional Power, Control And Durability. It Delivers 1,770 Ft - Lbs. (2,400 Nm) Of Maximum Torque, With A 5,250 RPM Free Speed at 120 Psi And Features A High - Efficiency 6 - Vane Motor. The Integral 360° Swivel Inlet Makes Kinked Hoses A Thing Of The Past. The Swept - Back 285B Handle Provides Excellent Maneuverability, With An Available 6" Extended Anvil For Even More Accessibility. Features Delivers 1,770 Ft - Lbs. (2,400 Nm) Maximum Torque. Fast - Torque™ Delivers 1,000 Ft - Lbs. In 2 Seconds. Improved Feather Touch Trigger

IR - 285B

1" Heavy Duty Impact Wrench

IR - 285B - 6

1" Heavy Duty Impact Wrench With
6" Extended Anvil

IR - 285B - S6

#5 spline Heavy Duty Impact Wrench
With 6" Extended Anvil



Designed Specifically For High Volume Fleet Service, The Revolutionary Chainsaw - Grip Handle Provides Comfortable Control To The Operator. The 2190Ti Delivers An Impressive 1,650 Ft - Lbs. (2 237 Nm) Of Max Torque In A Lightweight Package. Features 1,650 Ft - Lbs. (2 237 Nm) Of Maximum Torque. Weighs Just 15.5 Lbs. (7 kg.) Robust Anvil Bushing Provides Long Life Under Heavy Shop Usage

IR - 2190Ti - 6

1" Heavy Duty Impact Wrench With
6" Extended Anvil

IR - 2190DTi - 6

1" Heavy Duty Impact Wrench With
6" Extended Anvil



CORDLESS ACCESSORIES

The Innovative New And Improved Iqv Seriestm Battery Charger Digitally Co Mmunicates With Every IQV Series Lithium - Ion Or 14.4V And 7.2V Nicd Battery, To Identify Chemistry Voltage And Condition, And Then Optimizes The Charging Cycle To Protect Cells And Enhance Battery Performance.

IR - BC10

IR Battery Charger





1/2" CORDLESS WRENCHES

The W7150 1/2" 20V High - Torque Impactool™ Is The Only Cordless Impact Wrench That Can Perform Pound - For - Pound With Our Best - In - Class 2135T1 Max, 1/2" Air Impactool, The W7150 Cordless Tool Will Make Quick Work Of Tough Jobs That Professional Technicians Do Every Day.

IR - W7150 - K2

1/2" Drive Cordless Impact Tool With Kit

IR - W7150 - K1

1/2" Drive Cordless Impact Tool With Kit

IR - W7250 - K1

1/2" Drive Cordless 2 - Extension Impact Tool With Kit



IR - W7150 - K1



IR - BC10

IR - N192



IR - W7250 - K1

3/8" CORDLESS WRENCHES

The W150 Is The Most Powerful And Durable Cordless Impact In Its Class. Patent - Pending Iqv™ Technology Provides Maximum Performance, Durability, And Battery Life. Compatible With Both Lithium - Ion And Nickel Cadmium 14.4V Iqv Batteries. The W150 Is Ideal For General Automotive And Service Work Such As Suspensions, Front - Ends, Brakes, Engines, And Body Work As Well As Many Manufacturing And Maintenance Applications.

IR - W150 - KL1

3/8" Cordless Impact Wrench With Battery and Charger

IR - R3130 - K2

3/8" Cordless Rat With Battery and Charger



IR - W7250 - K1

CORDLESS ACCESSORIES

IQV Series Nickel Cadmium Batteries Provide Reliable Performance At A Reasonable Price. Integrated Microprocessor Circuitry Optimizes Charging, Protects Cells, And Enhances Performance. Patent Pending IQV Grip Twist - To - Lock Battery Interface Ensures Snug Battery - Tool Connection With Little Risk Of Battery Dislodging.

IR - N192

IR 19.2v Nickel - Cadmium Battery



IR - W7250 - K1

1/4" RATCHET

The Ingersoll Rand 105 Series Air Ratchet Offers Professional Technicians An Outstanding Combination Of Value And Performance, Delivering Impressive Comfort And Durability. Extended Head Offers Longer Reach.

IR - 105 - L2

1/4" Mini Air Ratchet 25 Ft/Lb

IR - 105 - D2

1/4" Air Ratchet 25 Ft/Lb





3/8" RATCHET

Based On The Industry's Most Popular Ratchet, The 107XPA Delivers An Extra Measure Of Durability With An Advanced Head Design, Plus A Host Of Other Features.

IR - 107XPA

3/8" Heavy Duty Ratchet



With The 1105Max Series Air Ratchet, You Get Best - In - Class Power And Speed Coupled With Superior Features To Give You Max Power, Max Control And Max Comfort.

IR - 1105MAX - D3

3/8" Mini Air Ratchet With 30 Ft Large Bores of Torque



As A Member Of The Ingersoll Rand Family Of Max Tools, The 1207Max Series Air Ratchet Combines Best - In - Class Performance And A Full Complement Of Premium Features To Give Professional Technicians Max Power, Max Control, And Max Comfort. It's Another In The Long Line Of Tools Designed To Help Make Your Job Easier — And You More Productive.

IR - 1207MAX - D3

3/8" Ultra Duty Air Ratchet



1/2" RATCHET

The 1207Max Series Air Ratchet Combines Best - In - Class Performance And A Full Complement Of Premium Features To Give Professional Technicians Max Power, Max Control And Max Comfort. It's Another In The Long Line Of Tools Designed To Help Make Your Job Easier — And You More Productive.

IR - 1207MAX - D4

1/2" Ultra Duty Air Ratchet



GRINDERS

Long Lasting, Economical, And Ideal For General - Purpose Grinding, The 301B Delivers A Number Of Beneficial Features In One Compact Package. Right - Angle Configuration Provides Easy Access To Tight Spots, So You Can Grind, Break Sharp Edges, De - Burr, Port, And Polish Virtually Anywhere!

IR - 301

1/4" HP Angle Die Grinder



Standard Duty Mini Die Grinder. Standard 1/4" Collet. Safety Lever And Front Exhaust. 1/4" Hp Motor.

IR - 307A

1/4" HP Mini Die Grinder



Heavy Duty 1/2" Hp Air Die Grinder. Positive Grip 1/4" Collet Chuck. Self - Locking Throttle Lever. 1/4" Hp Motor.

IR - 308A

1/2" HP Air Die Grinder

IR - 308BK

1/2" HP Air Die Grinder With Kit





GRINDERS

The 3445 Is The Perfect Choice For High Performance Material Removal. This 4.5" Air Angle Grinder Combines A Unique Internal Governor With A Powerful 0.88 Hp Motor To Give You A Best - In - Class Power - To - Weight Ratio Grinder That Will Maximize Your Rate Of Material Removal.

IR - 3445

4 - 1/2" Angle Air Grinder 8 Hose Power



AIR SANDERS

For Small Jobs And Hard - To - Reach Places, The 317A Is An Economical High - Speed Sander, Ideal For Light Sanding, Feather Edging And Rust Removal.

IR - 317A

Heavy Duty High Speed Sander - 5" Pad



At 15,000 Rpm, This Mini Random Orbital Sander Gets The Job Done. Delivers Swirl - Free Finishes When Feather Edging, Removing Rust, Preparing Metal Surfaces Or Smoothing Welds. Durable Ball - Bearing Construction Ensures Smooth Power Delivery. Kit Includes 71 - Piece Hook - And - Loop Discs.

IR - 3128K

Mini Random Orbital Sander Kit. Includes 71- Piece Loop And Disc



With Up To 5,000 Rpm Free Speed, You Can Work Faster On Light And Heavy Sanding Jobs, Including Rouging Body Filler, Removing Rust, And Smoothing Welds.

IR - 313A

Heavy Duty Angle Sander - 7" Pad



This Fine 3/32" (2.5 mm) Orbit, Vacuum - Ready, Low - Vibration Sander Helps Users Acheive High - Quality Paint Finishes. The 4152 - HI Utilizes A Precision Ground Counterbalance To Reduce Vibration. The 4152 - HI Extracts Dust And Particles Through And Around The Pad, Keeping Foreign Matter Away From The Motor. Virtually All Dust Is Instantly Chanelled Away From The Work.

IR - 4152 - HL

Orbit Palm Air Sander - 12000Rpm



POLISHERS

With Up To 5,000 Rpm Free Speed And A 0.75 Hp (0.60 Kw) Motor, You Can Work Faster On Light And Heavy Sanding Jobs, Including Rouging Body Filler, Removing Rust, And Smoothing Welds.

IR - 319A

Heavy Duty Vertical Polisher/Buffer - 7" Pad





POLISHERS

Buff And Polish All Painted Surfaces Easily. This Compact, Light - Weight Vertical Polisher/Buffer Gives You The Results You Want, Even On The Tough Jobs. The Variable Speed Control Lever Throttle Helps Eliminate Paint Burning. Comes Complete With 7" (178 mm) Backing Pad.

IR - 318A

Heavy Duty Angle Polisher/Buffer - 7" Pad



A Versatile Tool With A High Free Speed Range Of 1500 - 2500 Rpm For Buffing And Polishing A Wide Range Of Surfaces - Paint, Metal, And Plastic To A High - Gloss, Professional Finish. With Its Heavy Duty Motor, This Polisher Can Handle The Toughest Jobs. Comes Complete With 7" (178 mm) Backing Pad.

IR - 314A

Heavy Duty Angle Polisher - 7" Pad



NEEDLE SCALER

For Surface Preparation Work Involving The Cleaning Or Removal Of Paint, Rust, Dirt, Or Weld Slag, The 125 Is A Durable, Dependable, Economical Solution.

IR - 125

Standard Duty Needle Scaler



AIR HAMMER

Combine The 121 - Q Air Hammer Into The Convenience Of A Kit. Kit Includes 121 Air Hammer, Blow - Molded Black Carrying Case, And (6) Six Assorted Chisels. Assorted Chisels Include (1) 3/4" Flat Blade Chisel, (1) Punch Chisel, (1) Claw Ripper - Edging Tool, (1) Single Blade Cutter, (1) Kwik Cutter, (1) Vee Chisel - Spot Welder Breaker.

IR - 121K6

Air Hammer 3000 BPM With Chisels



Combine The 115 Air Hammer Into The Convenience Of A Kit. Kit Includes 115 Air Hammer And Five (5) Assorted Chisels. Assorted Chisels Include (1) Punch Chisel, (1) Edging Tool, (1) Tail Pipe Cutter, (1) 3/4" Wide Blade Straight Chisel, (1) Cutting Chisel.

IR - 115K

Air Hammer With 5-Piece Chisel Set



An Economical Air Hammer With A Longer Piston Stroke, This Tool Is Designed For Exhaust Work, Bolt Cutting, And Front End Work. The Trigger Control An A Built - In Power Regulator Give You Full Control Of The Speed And Power. Combine The 117 Air Hammer Into The Convenience Of A Kit. Kit Includes 117 Air Hammer And Five (5) Assorted Chisels. Assorted Chisels Include (1) Punch Chisel, (1) Edging Tool, (1) Tail Pipe Cutter, (1) 3/4" Wide Blade Straight Chisel (1) Cutting Chisel.

IR - 117

Air Hammer - Long - Stroke Piston

IR - 117K

Air Hammer With 5 - Piece Chisel Set



INGERSOLL RAND ACCESSORIES

Code	Description
IR - 231HA - P32	Protective Cover For IR - 231HA
IR - CG - 2705	Comfort Grip For IR - 231 Series
IR - 285 - P32	Protective Cover For IR - 285B - 6
IR - W360 - BOOT	IR - W360 - Protective Cover
IR - 2135TI - P32	Protective Cover For IR - 2135
IR - 2115TI - P32	Protective Cover For IR - 2115
IR - 2145 - P32	Protective Cover For IR - 2145QI
IR - 244 - BOOT	IR - 244 - Protective Cover
IR - 212 - BOOT	IR - 212 - Protective Cover
IR - 1215 - K35	IR - 1215 Part - Crankshaft Kit
IR - 1215 - 330	IR - 1215 Part - Drive Bushing
IR - 285B - TK1	IR - 285B Series Tune - Up Kit
IR - 281 - TK1	IR - 281 Series Tune - Up Kit
IR - 261 - TK2	IR - 261 Series Tune - Up Kit
IR - 2131 - TK2	IR - 2131 Series Tune - Up Kit
IR - 2135 - TK2	IR - 2135 Series Tune - Up Kit
IR - 231 - TK2	IR - 231H Impact Wrench Tune - Up Kit
IR - 231B - THK1	IR - 231 Hammer Tune - Up Kit
IR - 2135 - 425	IR - 1/2" Drive Retainer Ring
IR - R1A - 159	IR - 1/2" Drive O - Ring
IR - 231 - 425A	IR - 1/2" Drive Retainer Ring
IR - 285B - A565	IR - 285B - Inlet Bushing Assembly
IR - 285B - S - 918	IR - 285B - S6 - #5 Spline Retainer Ring
IR - 231B - A626	IR - 231/2" 135 - Anvil Assembly
IR - 231HP - TK1	IR - 231 Series - Tune - Up Kit
IR - 2141 - TK1	IR - 2141 - Tune - Up Kit
IR - 2190 - TK1	IR - 2190 - Tune - Up Kit



IR - 244 - BOOT



IR - 2135 - TK2



IR - 231 - TK2



IR - 231B - THK1



AIR SAW

The 429 Is A Versatile Air Saw For Cutting Intricate Shapes And Light Radius Curves In All Types Of Plastics, Fiberglass, And Composite Materials, As Well As Aluminum And Sheet Metal. This Reduced Vibration Tool Is Excellent For Body Shop Repair, Muffler And Exhaust Work, And Sun Roof Installations.

IR - 429

IR - Air Reciprocating Saw



AIR CUT - OFF TOOL

Exhaust Replacement Is This Powerful Tool's Specialty. Now You Can Cut Off Mufflers And Tail Pipes Quickly, Efficiently And Quietly. It Has A 20,000 Rpm Motor That Can Handle The Toughest Exhaust Replacements And Cut Sheet Metal, Nuts And Bolts.

IR - 326

Air Operated. 2 - 7/8" Cut Off Tool



DRILLS

One Tool In A Family Of Economical, Standard - Duty Tools, The 7807R Series Is An Excellent Choice For Service Work Requiring A Compact, Low Profile Angle Head. It's A Durable, Reliable Tool For Drilling In All Types Of Materials, Including Sheet Metal, Wood And Composites.

IR - 7807R

3/8" Drive Air Angle Drill - Rev.



If You Need More Power In Your Drill Turn To Ingersoll Rand's Line Of High Quality 1/2" (13 mm) Drills. Our Latest Models Have Speed Ranges From 400 To 500 Rpm And Pump Out 0.50 Hp (0.38 Kw). Drill Configurations Include Reversible, Non - Reversible And Keyless Chucks.

IR - 7803RAKC

1/2" Heavy Duty Drill - Reverse Keyless Chuck



GREASE GUN

For Flush - Type Fittings, 3 Oz. Capacity

IR - R000A2 - 228

Grease Gun



Standard - Duty Impact Wrench Grease

IR - 100 - 1LB

IR Grease



285B-6 1" Heavy Duty Extended Anvil Impact

**Now even MORE
performance from
the world
leader in
impacts**

FREE
CHEMICAL RESISTANT BOOT
\$31 Value



- **More Power**
 - delivers 1,770 ft-lb maximum torque
 - 2 second FAST-torque™
- **More Control**
 - improved feather-touch trigger
 - 3 position power regulator
- **More Durability**
 - new increased pressure rating
 - new hammer design

IR Ingersoll Rand

www.irttools.com



1/4" IMPACT WRENCHES

High Torque In Small Package. Benefits General Maintenance. Clutch Delivers Smooth Operation For Better Comfort. Robust And Reliable. Power And Economy For General Repair Application. Features A 1/4" Impact Wrench. Dyna - Pact Oil Bath Clutch. One - Handed Push Button Forward/Reverse With 4 Positive Power Settings. Full Power In Reverse Through Handle Air Exhaust And 360° Air Inlet Swivel.

CP - 719

1/4" Heavy Duty Impact Wrench



3/8" IMPACT WRENCHES

High Torque In Small Package. Benefits General Maintenance. Clutch Delivers Smooth Operation For Better Comfort. Robust And Reliable. Power And Economy For General Repair Application. Features A 3/8" Impact Wrench. Dyna - Pact Oil Bath Clutch. One - Handed Push Button Forward/Reverse With 4 Positive Power Settings. Full Power In Reverse Through Handle Air Exhaust And 360° Air Inlet Swivel.

CP - 724H

3/8" Heavy Duty Impact Wrench



CP - 7729

3/8" Heavy Duty Impact Wrench

3/8" AIR RATCHET

Powerful, Quiet, Durable And Light With Sturdy Aluminum Alloy Head. Lightweight And Well Balanced Thanks To Special Head. Ratchets For General Maintenance, Durability And Comfort. Features 3/8" High Power Club Ratchet. Adjustable Side Exhaust, Low Noise, Progressive Tease Throttle. Highest Torque On The Market: 90 Ft.Lbs(122 Nm). Grease Fitting On The Reverse Button. Features Cp's Patented Trispring Anti - Slip Head Design With Protective Head Cover .

CP - 7830Q

3/8" CP Heavy Duty Air Ratchet - Quiet



1/2" IMPACT WRENCHES

The "Classic" Reference For 1/2" Impact Tools. Benefits General Maintenance. Clutch Delivers Smooth And Comfortable Operation. Robust Housing And Oil Bath Clutch Provide High Durability. Versatile And Powerful Tool Ideal For All General Repair And Maintenance Applications. Features 1/2" Impact Wrench With Ring Retainer. Dyna - Pact (Pin Clutch) With Oil Bath. One - Handed Reverse Button With 4 Positive Power Settings. Compact And Ergonomic With Rubber Grip, Through Handle Air Exhaust And 360° Air Inlet Swivel.

CP - 734H

1/2" General Impact Wrench With Handle



Durable And Versatile. Best Power / Weight / Speed Ratio In Its Class. Ideal For General Automotive Service, Tire And Body Shops, Farm And Light Truck Work. Features 1/2" Impact Wrench And CP's Patented Springhammer Clutch. Low Air Consumption And High Torque. Full Teasing Trigger.

CP - 7733

1/2" Heavy Duty Impact Wrench





1/2" IMPACT WRENCHES

Durable And Versatile. Benefits Best Power / Weight / Speed Ratio In Its Class. Ideal For General Automotive Service, Tire And Body Shops, Farm And Light Truck Work. Features 1/2" Impact Wrench. CP'S Patented Springhammer Clutch. Low Air Consumption And High Torque. Full Teasing Trigger 2" Extended Anvil For Tire Work.

CP - 7733 - 2

1/2" Heavy Duty Impact Wrench



Extreme Torque And Power. Benefits General Maintenance. Maximize Work Efficiency Thanks To Extreme Torque. Insulated And Comfortable Grip With Rubber Injected Composite Housing. Features 1/2" Composite Impact Wrench With Ring Retainer. 920 Ft.Lbs. Of Maximum Torque In Reverse. Aluminum Clutch And Rear Housing. Thermo - Plastic Rubber Injected In Housing For A Durable And Comfortable Grip. Thermo - Plastic Rubber Injected In Housing For A Durable And Comfortable Grip. Universal And Durable Twin Hammer Mechanism. Full Teasing Ergonomically Developed Trigger, 360° Swivel Air Inlet.

CP - 7748

1/2" Drive Impact Wrench



CP - 7748 - 2

1/2" Drive Impact Wrench With 2" Extended Anvil

Balanced And Powerful. Benefits Maximize Operator Comfort With An Extremely Well Balanced Tool. Most Convenient And Unique Reverse Technology In The Market. Twin Hammer Clutch. Composite Handle And Magnesium Clutch Housing. S2s Technology And 3 Positive Power Settings. Full Power In Reverse Up To 750 Ft.Lbs. Lightweight And Low Noise Level Tool.

CP - 7749

1/2" Drive Impact Wrench

CP - 7749 - 2

1/2" Drive Impact Wrench With 2" Extended Anvil



1/2" IMPACT WRENCHES

Benefits New Technology Maximizing Comfort And Power For General Maintenance. Maximize Operator Comfort Thanks To Unique CP Handle Design. Great Power In A Lightweight Package. Side - To - Side: The Most Convenient Reverse Technology In The Market. Features 1/2" Composite And Carbon Fiber Impact Wrench. Rugged Technology With Carbon Fiber Inlay. Lightweight With A Magnesium Clutch Housing. S2S Easy Forward Reverse: Side To Side Patented Technology. 780Ft.Lbs(1,054Nm) Of Maximum Torque In Reverse. Universal And Durable Twin Hammer Mechanism. Full Teasing Ergonomically - Developed Trigger. Ergonomic Handle In Composite Material. Integrated Muffler For Low Noise. Flexible 360° Swivel Air Inlet.

CP - 7759Q

1/2" Drive Impact Wrench

CP - 7759Q - 2

1/2" Drive Impact Wrench With 2" Anvil





1/2" IMPACT WRENCHES

Reliable And Rugged. Benefits General Maintenance, Operator Comfort And Productivity. Withstands Rough Use With High Speed And Power. Ideal For General Repair. Features 1/2" Impact Wrench With Ring Socket Retainer. CP'S Patented Clutch. One - Handed Reverse Button With 4 - Power Settings. Compact Design With Comfortable Contoured Handle.

CP - 749

1/2" Maximum Heavy Duty Impact Wrench

CP - 749K

1/2" Heavy Duty Impact Wrench Kit



Kit ShoWn

Reliable And Rugged. Benefits Operator Comfort And Productivity. Withstands Rough Use With High Speed And Power. Ideal For General Automotive Service, Tire And Body Shops, Farm And Light Truck Work. Features 1/2" Impact Wrench. CP'S Patented Springhammer Clutch. One - Handed Push Button Forward/Reverse With 4 Positive Power Settings. Full Power In Reverse. Compact Design With Comfortable Contoured Handle. Plus 2" Extended Anvil.

CP - 749 - 2

1/2" Max Heavy Duty Impact Wrench With Spring Hammer Clutch



3/4" IMPACT WRENCHES

Powerful For General Maintenance Applications. Powerful Motor And Durable Clutch. Operator Comfort. Features 3/4" Impact Wrench With Ring Retainer. Twin Hammer Clutch. High Power: 1,200 Ft.Lbs(1,627 Nm). Combined Power Regulator With Forward/Reverse.

CP - 7763

3/4" Drive Ultra Torque Impact Wrench



Compact And High Torque. Benefits Powerful Motor And Durable Clutch. Operator Comfort. Ideal For Spring Work, Pinion Nut, Tractor Pad Removal, Truck Tire Work And Major Engine Teardowns. Features 3/4" Impact Wrench. Twin Hammer Clutch. High Power: 1,200 Ft.Lbs. Combined Power Regulator With Forward/Reverse. 6" Extended Anvil (Dual Socket Retainer).

CP - 7763 - 6

3/4" Ultra Torque Impact Wrench With 6" Extension



3/4" IMPACT WRENCHES

The Unmatched "Reference" In 3/4" Impact. Benefits General Maintenance. Smooth Operation Thanks To The Dyna - Pact Clutch. Comfortable Use Thanks To Low Noise And Vibration Levels. Good Durability. Ideal For Repair On Heavy Machinery And Large Equipment. Features 3/4" Impact Wrench With Ring Retainer. Dyna - Pact Oil Bath Clutch. One - Handed Reverse Button With 4 Settings Of Power. Comfortable Handle Grip. 360° Air Inlet Swivel.

CP - 772H

3/4" Heavy Duty Impact Wrench





3/4" IMPACT WRENCHES

Unmatched Durability. Benefits Smoothest Operating Tool With Unmatched Durability. Operator Comfort. Ideal For Spring Work, Truck And Bus Maintenance, Farm Machinery And Construction Equipment. Features 3/4" Impact Wrench. Pin Clutch Oil Bath. One - Handed Push Button Forward/Reverse With 4 Positive Power Settings. Full Power In Reverse. New Comfortable Contoured Handle Grip. 360° Air Inlet Swivel. Plus 6" Extended Anvil.

CP - 772H - 6

3/4" Heavy Duty Impact Wrench With 6" Anvil



1" IMPACT WRENCHES

High Torque And Comfort. Benefits. High Efficiency Motor, Yet Economical With Durable Reinforced Clutch Mechanism. Durable Impact Wrench With Great Power For The Toughest Jobs On Heavy Vehicles. Features. #5 Spline Straight Impact Wrench With 6" Extended Anvil. 2140Ft.Lbs - 2900 Nm Of Maximum Torque In Reverse. Pinless Closed Reinforced Rocking Dog Impact Mechanism. Socket Retainer Ring Combined With Hole Retainer. Ergonomic Side Handle. Full Teasing Trigger. Regulator With Integrated Forward/Reverse With 3 - Position Power Settings In Both Directions.

CP - 797SP - 6

1" Extended Heavy Duty Impact Wrench With 6" Extended Anvil



CP - 7782 - 6

1" Drive Heavy Duty Impact Wrench With 6" Extended Anvil - 1850 Ft Large Bores

DIE GRINDER

Compact And Lightweight. General Maintenance Applications Angle Die Grinder. Compact And Lightweight Tool Designed For Easy Maneuverability. Ideal For Limited Space Applications. Features 1/4" And 6 mm Collets. 90° Angle Head Allows Flexibility In Tight Areas. Built - In Air Regulator.

CP - 860

1/4" Heavy Duty Die Grinder - 24,000 RPM

CP - 875

Mini Angle Die Grinder



AIR HAMMER

Powerful For General Maintenance Applications. Powerful Motor And Durable Clutch. Operator Comfort. Features 3/4" Impact Wrench With Ring Retainer. Twin Hammer Clutch. High Power: 1,200 Ft.Lbs (1,627 Nm). Combined Power Regulator With Forward/Reverse.

CP - 7110

Heavy Duty Air Hammer With Chisels

CP - 717K

SCPEC Heavy Duty Hammer With Tool Kit



ANGLE GRINDER

Compact And Lightweight. General Maintenance Applications Angle Die Grinder. Compact And Lightweight Tool Designed For Easy Maneuverability. Ideal For Limited Space Applications. Features 1/4" And 6 mm Collets. 90° Angle Head Allows Flexibility In Tight Areas. Built - In Air Regulator.

CP - 879

3/8" Angle Grinder/Drill





Chicago Pneumatic

The Chicago Pneumatic and Prema Canada Team

1/2" Drive



CP7748-2
Composite Impact
 - Max torque 922 ft-lbs.
 - Brute Force impacting



CP7759Q-2
Carbon Fiber Impact
 - Max torque 780 ft-lbs.
 - Ergonomic, quiet and lightweight



CP7733-2
Heavy Duty Impact
 - Max. torque 550 ft-lbs.
 - Patented SPRINGHAMMER clutch



CP7748



CP7759Q



General maintenance & tire changing



New technology maximizing comfort



Ideal for tire and body shops

3/4" & 1" Drive



CP772H-6
Heavy Duty Impact with 6" anvil
 - Max. torque 1,000 ft-lbs.
 - DYNA-PACT oil bath clutch
 - 3/4" Drive



CP7779
Heavy Duty Impact
 - Max. torque 1,440 ft-lbs.
 - Durable twin hammer clutch
 - 1" Drive



CP873K
Low Speed Tire Buffer Kit
 - 2,800 RPM free speed
 - Includes whip and exhaust hose

1" Drive

Highly durable impact with great power for trucks, buses and heavy equipment applications



CP7782-6
Heavy Duty Impact with 6" anvil
 - Max. torque 2,140 ft-lbs.
 - Pinless closed reinforced rocking dog impact mechanism

High power to weight ratio for general and heavy duty truck maintenance applications



CP7780-6
Heavy Duty Impact with 6" anvil
 - Max. torque 1,700 ft-lbs.
 - Super light, only 17 lbs.

CP PARTS AND ACCESSORIES

Code	Description
CA - 155537	Protection Cover - CP 749 Series
8940163046	Protection Cover - CP 7740 Series
8940158793	Protection Cover - 7750 Series
CA - 124745	Protection Cover - CP 772 Series
CA - 154948	Protection Cover - CP 776 Series
CA - 139818	Protection Cover - CP 797 Series
8940162416	CP - 7775 - 6 - Protection Cover
8940163099	Protection Cover - Cp 7778 - 6
CA - 131501	CP - 797 - 6 Tune - Up Kit
CA - 094791	1" Drive Retainer Ring
CA - 087404	3/4" Drive Retainer Ring
CA - 088097	1/2" Drive Retainerring
P - 083071	1/2" Drive O - Ring For Anvil
H - 082651	1" Drive O - Ring For Anvil
8940162206	CP - 7775 Series - Tune - Up Kit
CA - 145228	CP - 898 Series - Tune - Up Kit
8940158860	CP - 7733 Series - Tune - Up Kit
8940158635	Kit - Tune - Up CP 749 Model
CA149158	Kit Tune - Up Cp 0776
8940167481	CP - 7749 Part - Tune - Up Kit
8940167482	CP - 7749 - Repair Kit

CA - 155537



CA - 124745



CA - 131501

H - 082651

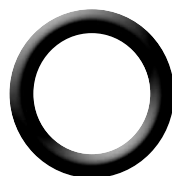

CA - 087404



8940162206



8940158860



CA - 149747

CA - 145228





Retread/Section Equipment And Supplies



**CHEMICAL RUBBER COMPOUNDS**

A And B Compound 2Lb. Set. CFC Free Version. Used For Cosmetic Repair Of Tire And Conveyor Belt Surfaces. Use In Conjunction With Rema BL - 8 Special Blue Cement Under Cold Vulcanizing Process.

Code	Description
PAB - F	A And B Compound 2Lb Set
51F	A And B Compound 2Lb Set
50F	A And B Compound 4Lb Set



PAB - F

CUSHION AND EXTRUDED RUBBER COMPOUNDS

Cushion Gum Used To Fill Buzz - Outs, Exposed Cords, Spot Repairs And Sections. Cure Rate 20 Minutes. At 280 Degrees F. Shelf Life 1 Year. Use With Black Vulcanizing Cement. 18" Width x 1/16" Gauge (Thick).

Code	Description
CU914 - 18X060	Cushion Gum - 18" X 1/16" 12 Lbs



PAB - F

EM Thermo Rubber Bars

Code	Description
5161190	EM Thermo Rubber Bars

Tread Gum - 18" x 1/16" 12Lb.

Code	Description
TG914 - 18X060	Tread Gum - 18" X 1/16" 12Lb



RR914 - 38

3/8" Rope Rubber Used To Fill Buzz - Outs

Code	Description
RR914 - 38	3/8" Rope Rubber Fast Cure (Per Lb)
RR549 - 38	3/8" Rope Rubber Fast Cure (Per Lb)



5177378

Code	Description
5177300	T2 Comp. A Ext Rope - 6 kg Box
5177310	T2 Comp. B Ext Rope - 6 kg Box
5177361	T2 Solution A 1kg
5177378	T2 Solution B 1kg
5561	Multi Temperature Cushion Gum
5563	Multi Temperature Cusion Gum - 8 X 2Lbs
5567 - 26.5	Multi Temperature Rope Rubber 26.5 Lb
5161180	Multi Temperature CR Rope Rubber
5570	Blue Floater Gum 1/32" X 20"
5571	Blue Floater Gum 1/32" X 7"



5177361

SILICONE LUBRICANT

Silicone Mold Lubricant For Use In Retread Applications

Code	Description	Size
1 - 210	Silicone Mold Lubricant - Concentrated	1G
5 - 210	Silicone Mold Lubricant - Concentrated	5G



1 - 210

**CURING ENVELOPES - INSIDE AND OUTSIDE***Robbins Outside Envelope With Valve Bead To Bead. Two Envelopes Per Box.*

Code	Description	Size	Qty
4214 - 32	Robbins Outside Envelope With Valve	42" X 14" - 32" Bead To Bead	Two Envelopes Per Box.
4215 - 35	Robbins Outside Envelope With Valve	42" X 15" - 35" Bead To Bead	Two Envelopes Per Box.
3213 - 25	Robbins Outside Envelope With Valve	32" X 13" - 24" Bead To Bead	Two Envelopes Per Box.
2910 - 25	Robbins Outside Envelope With Valve	29" X 10" - 25" Bead To Bead	Two Envelopes Per Box.
3511 - 30	Robbins Outside Envelope With Valve	35" X 11" - 30" Bead To Bead	Two Envelopes Per Box.
4219 - 30	Robbins Outside Envelope With Valve	42" X 19" - 30" Bead To Bead	Two Envelopes Per Box.
4213 - 37	Robbins Outside Envelope With Valve	42" X 13" - 37" Bead To Bead	Two Envelopes Per Box.
4416 - 36	Robbins Outside Envelope With Valve	44" X 16" - 36" Bead To Bead	Two Envelopes Per Box.
3513 - 28	Robbins Outside Envelope With Valve	35" X 13" - 28" Bead To Bead	Two Envelopes Per Box.
4221 - 29	Robbins Outside Envelope With Valve	42" X 21" - 29" Bead To Bead	Two Envelopes Per Box.
3816 - 28	Robbins Outside Envelope With Valve	38" X 16" - 28" Bead To Bead	Two Envelopes Per Box.
3218 - 19	Robbins Outside Envelope With Valve	32" X 18" - 19" Bead To Bead	Two Envelopes Per Box.
3814 - 29	Robbins Outside Envelope With Valve	38" X 14" - 29" Bead To Bead	Two Envelopes Per Box.
4217 - 34	Robbins Outside Envelope With Valve	42" X 17" - 34" Bead To Bead	Two Envelopes Per Box.
4814 - 44	Robbins Outside Envelope With Valve	48" X 14" - 44" Bead To Bead	Two Envelopes Per Box.
4419 - 33	Robbins Outside Envelope With Valve	44" X 19" - 33" Bead To Bead	Two Envelopes Per Box.
4224 - 24	Robbins Outside Envelope With Valve	42" X 24" - 24" Bead To Bead	Two Envelopes Per Box.
3812 - 31	Robbins Outside Envelope With Valve	38" X 12" - 31" Bead To Bead	Two Envelopes Per Box.
4417 - 36	Robbins Outside Envelope With Valve	44" X 17" - 36" Bead To Bead	Two Envelopes Per Box.
3822 - 25	Robbins Outside Envelope With Valve	38" X 22" - 25" Bead To Bead	Two Envelopes Per Box.
3820 - 24	Robbins Outside Envelope With Valve	38" X 20" - 24" Bead To Bead	Two Envelopes Per Box.
4023 - 23	Robbins Outside Envelope With Valve	40" X 23" - 23" Bead To Bead	Two Envelopes Per Box.
3515 - 25	Robbins Outside Envelope With Valve	35" X 15" - 25" Bead To Bead	Two Envelopes Per Box.
55 - 5X17 - OTR	Robbins OTR Envelope With 2 Valves This Is An Outside Envelope For OTR Tires		
4223 - 27	Robbins Outside Envelope With Valve	42" X 23" - 27" Bead To Bead	Two Envelopes Per Box.
4422 - 29	Robbins Outside Envelope With Valve	44" X 22" - 29" Bead To Bead	Two Envelopes Per Box.
4415 - 38	Robbins Outside Envelope With Valve		
3818 - 22 - 5	Robbins Inside Envelope	38" X 18" - 22.5 Bead To Bead	Two Envelopes Per Box.
2957 - 19 - 5	Robbins Inside Envelope	29" X 57" - 19.5 Bead To Bead	Two Envelopes Per Box.
3218 - 19 - 5	Robbins Inside Envelope	32" X 18" - 19.5 Bead To Bead	Two Envelopes Per Box.
2957 - 17 - 5	Robbins Inside Envelope	29" X 57" - 17.5 Bead To Bead	Two Envelopes Per Box.
4028 - 22 - 5	Robbins Inside Envelope	40" X 28" - 22.5 Bead To Bead	Two Envelopes Per Box.
4028 - 24 - 5	Robbins Inside Envelope	40" X 28" - 24.5 Bead To Bead	Two Envelopes Per Box.
4008 - 22 - 5	Robbins Inside Envelope	40" X 8" - 22.5" Bead To Bead	Two Envelopes Per Box.
3508 - 22 - 5	Robbins Inside Envelope	35" X 8" - 22.5 Bead To Bead	Two Envelopes Per Box.



4214 - 32

ENVELOPE CHECK STATION

833400 B&J Envelope Check Centre

MOUNTING LUBRICANT*Robbins Envelope Lubricant. Spray To Start And Then Every 30 Cures. Ready To Use, No Dilution Required.*

Code	Description	Size
5612	Robbins Envelope Lubricant	1G
5613	Robbins Envelope Lubricant	5G



5613

**TIRE PAINT***Concentrated Water - Based Black Tire Paint. Covers Crayon Marks, Scuffs And Dirt To Give The Tire A New Fresh Look.*

Code	Description
5656 - 5	Premier Performance Concentrated Black Tire Paint 5G
5659 - 5	Ready To Use No Voc Black Tire Paint 5G
5656 - 55	Premier Performance Concentrated Black Tire Paint 55G
5659 - 55	Ready To Use No Voc Black Tire Paint 55G
BTP - E844 - 5G	Stoner Concentrated Black Tire Paint 55G
162 - 233 - 55G	Solvent - Based Black Tire Paint 55G



5656 - 5



5659 - 55



1201B - 1QT

RETREADING - VULCANIZING CHEMICALS

Code	Description
1201B - 1QT	Poly Bond - Brush Type 1QT
1201B - 1G	Poly Bond - Brush Type 1G
1201B - 5G	Poly Bond - Brush Type 5G
1201S - 5G	Poly Bond - Spray Type 5G

CEMENT CANS, BRUSHES AND ACCESSORIES

Code	Description
968	Aluminum Cement Dispenser Lid / Brush Assembly For 968
968B	Lid/Brush Assembly For 968
84 - 029	Stipple Brush - 1.5"
12SB	Quart Plastic Can With Brush
K - 533	Replacement Brush For K - 534
K - 534	Aluminum Cement Can With Brush - 8 oz
K - 535	Aluminum Cement Can With Brush - 32 oz
K - 632	SS MDL B - Plastic - Aluminum Atomizer - 16 oz
8100PL	SS MDL B - Chrome - Aluminum Atomizer - 16 oz
8100CB	Sure Shot Model A Sprayer 1 quart
2000	Pump And Spray Bottle With Viton Seal
FBS - 50100	Viton Repair Kit For FBS - 50100
FBS - 50170	Sure Shot Model A Repair Kit
2000 - RK10	Sure Shot Model A Repair Kit



968B



K - 533

CARBIDE CUTTING BURRS

Code	Description
2 - 280	Mini Pointed Diamond Cutter
283	6455 Mini Router Burr
284	6454 Rema Router Burr
286	6453 Ball Shaped Burr
EA - 10467	Carbide Burr - D/C 1/4" Shank - 5/8"



2 - 280



286

**ROTARY GOUGERS AND SHARPENERS**

Code	Description
11 - 603	Rotary Gouge - 1 - 1/4" X 3/8" Thread Arbor Hole No Notch
11 - 604	Rotary Gouge - 1 - 1/4" X 3/8" No Notch
11 - 605	Rotary Gouge - 2" X 1/2" Arbor Hole - No Notch
11 - 606	Rotary Gouge - 2" X 1/2" Arbor Hole - Notch
11 - 607	Micro Gouge - 3/4" X 3/8" No Notch
11 - 610	Thin Wall Rotary Gouge - 2" X 3/8" Arbor Hole No Notch
11 - 612	Thin Wall Rotary Gouge - 2" X 3/8" Arbor Hole Notch
11 - 626	3/4" And 1 - 1/4" Gouge Sharpener Set
11 - 635	Small Replacement Stone - 1 - 1/4" And 2"
11 - 636	Large Replacement Stone - 3/4" And 1 - 1/4"



11 - 603



11 - 635



17 - 200



S871



S871



2 - S879

ALUMINUM OXIDE GRINDING STONES

Code	Description
S870	B - 97 Mini Point White Stone
S871	A - 1 Large Conical White Stone
2 - S871	A - 1 Large Conical White Stone
S872	A - 15 Standard Point White Stone
2 - S872	A - 15 Standard Point White Stone
2 - S872B	A - 15 Standard Point Brown Stone
2 - S872S	A - 15 Small Point White Stone
S873	A - 36 Standard Mushroom White Stone
2 - S873	A - 36 Standard Mushroom White Stone
2 - S873B	A - 36 Standard Mushroom Brown Stone
AG1220	A36 Mounted Point Black Stone
S874	B - 72 Mini Mushroom White Stone
S875	A - 5 Standard Conical White Stone
2 - S875	A - 5 Standard Conical White Stone
S879	A - 37 Small Mushroom White Stone
2 - S879	A - 37 Small Mushroom White Stone
2 - S879B	A - 37 Small Mushroom Brown Stone

TEXTURIZING BRUSHES

Code	Description
S890	Encapsulated Brush 2"
S891	Encapsulated Brush 3"
EA - 09493	2" Encapsulated Brush
EA - 08903	2 - 1/2" Crimped Wire Wheel .014 Gallon
S892	Texture Brush 3"
S892W	S892 Washer Only 2 Diameter 1/2" Arbor Hole
S896	1/2" Pen Skive Brush 1/4" Soft
S897	Grumac Encapsulated Brush 2"
21134	Nylox 3/4" Power Tube Brush
6055	2" Encapsulated Wire Wheel
6056	3" Encapsulated Wire Wheel



S890



S891



S896

KNIVES AND SCISSORS

Code	Description
940	Taper Point Skive Knife
941	Extra Curve Skiver
942	Flexible Round Point Knife
RUSX10X1 - 1/4S	10 X 1 - 1/4" Skiver
MH26470	Electric Knife Heater 115V
MH26000	Electric Knife Heater (UI)
RUSK - 8S	Insulated 8" Hot Knife
MK42810	4" Square Point Heater Knife
MK42820	8" Square Point Heater Knife
VV - 1004502	Vulcanizing Bail 105 - 13 X 2 - 1/2" Knife
DEX - 60310	Straight Blade Knife
14 - 291	Knife Sharpener
DEX - 60040	Rubber Knife - Blade 4 X 1
DEX - 60110	Rubber Knife - Blade 6 X 1
531 - 75330	Square Point Knife - 3 - 5/8"
DEX - 60300	Curved End Knife - 1 - 1/8" Notch
6017	Skive Knife - Narrow 5" Blade
6018	Skive Knife - Standard 6" Blade
SS10	10" Straight Scissors
K - 24A	12" Bent Handle Industrial Shears
DEX - 71220	Mill Blade 6 X 5/8"
DEX - 71120	Mill Blade 6.5 X 3/4"
DEX - 71130	Mill Blade 6.5 X 3/4"
DEX - 71180	Mill Blade 9 X 3/4"
DH73040	Mill Blade 9 X 5/8" X .072" Thick
DH73110	Mill Blade 6 X 5/8" X .072" Thick
K - 55MB	Dexter 40933 Tri mmer Blade
MK41580	Mill/Tri mmer Blade Slot Screw
DEX - 70040	Blade Handle Holds 9/16" And 1/2"
DEX - 70100	Blade Handle Holds 5/8" Blades
DEX - 70060	Blade Handle Holds 3/4" Blades

MH26470

S897

RUSK - 8S

940

K - 24A

DEX - 60300

SS10

S871
K - 55MB
RUBBERHOG FLARED CONTOUR CUPS

Code	Description	Size	Grit
RH100	Flared Contour Wheel	1 3/4"	SSG 170
RH102	Flared Contour Wheel	1 3/4"	SSG 230
RH107	Flared Contour Wheel	2 1/2"	SSG 170
RH107 - 60	Flared Contour Wheel	2 1/2"	SSG 60
RH109	Flared Contour Wheel	2 1/2"	SSG 230
RH111	Flared Contour Wheel	2 1/2"	SSG 390
RH112	Contour Wheel	3"	SSG 170
RH114	Contour Wheel	3"	SSG 230
RH116	Flared Contour Wheel	3" X 1 - 1/4"	SSG 390
RH118	Flared Contour Wheel	3" 1/2"	SSG 170
RH120	Flared Contour Wheel	3" 1/2"	SSG 230
RH122	Flared Contour Wheel	3" 1/2"	SSG 390
RH126	Flared Contour Wheel	4" X 1/2"	SSG 230
RH129P	Flared Contour Wheel	4" X 3/4"	SSG 390

RH129P

**RUBBERHOG ROUND FACED BUZZ - OUT WHEELS***Rubberhog Round Faced Buzz - Out Wheels. For Skiving And Texturing Section Repairs.*

Code	Description
RH300	2" X 1/4" Buzz-Out Wheels SSG 230
RH302	2" X 1/4" Buzz-Out Wheels SSG 390
RH304	2" X 3/8" Buzz-Out Wheels SSG 230
RH306	2" X 3/8" Buzz-Out Wheels SSG 390
RH308	2" X 1/2" Buzz-Out Wheels SSG 230



RH300



RH308

RUBBERHOG CONES, BALLS, RODS AND SPECIALTY TOOLS*Rubberhog Cones, Balls And Rods For Skiving And Texturing Section Repairs*

Code	Description
RH505	7/8" X 2" Cone SSG 230
RH507	7/8" X 2" Cone SSG 390
RH511	7/8" X 4" Cone SSG 390
RH551	1 - 1/8" Ball SSG 230
RH553	1 - 1/8" Ball SSG 390
RH601	5/8" Ball SSG 330
RH603	7/8" Ball SSG 330
RH611	5/8" Taper SSG 330
RH613	7/8" Taper SSG 330
RH619	1 - 3/8" Rotor Saw SSG 330
RH626	1/4" X 3" NHR SSG 330
RH635	1/8" Shank Tool Kit SSG 170
RH1150	4 X 5/8" Bore Sand Disc SSG 390
RH1160	7 X 7/8" Bore Sand Disc SSG 390
RH713	8 X 1 - 1/2" Large Unit Wheel 1 - 1/2" Arbor Hole



RH507



RH619



RH1160

SIMULATED RH FLARED CONTOUR CUPS

Code	Description
RH100 - S	Steel Shot Rubberhog 100 Simulation
RH106 - S	Steel Shot Rubberhog 106 Simulation
RH108 - S	Steel Shot Rubberhog 108 Simulation
RH110 - S	Steel Shot Rubberhog 110 Simulation
RH114 - S	Steel Shot Rubberhog 114 Simulation
RH116 - S	Steel Shot Rubberhog 116 Simulation
RH118 - S	Steel Shot Rubberhog 118 Simulation
RH120 - S	Steel Shot Rubberhog 120 Simulation
RH122 - S	Steel Shot Rubberhog 122 Simulation



RH116 - S



RH100 - S



RH106 - S

TAPER CONE

Code	Description	Size
WB2251 - 40	Taper Cone 1.69" - 2.23"	40 mm
WB2252 - 40	Taper Cone 2.15" - 2.58"	40 mm
WB2253 - 40	Taper Cone 2.50" - 2.94"	40 mm
WB2255 - 40	Taper Cone 3.20" - 3.63"	40 mm
WB725 - 40	Taper Cone 3.375" - 5.25"	40 mm



TUNGSTEN CARBIDE ROUND FACED BUZZ - OUT WHEELS

Tungsten Carbide Buzz-out Wheel. Air - Cooled Design Permits Faster, Cooler And Cleaner Buffing And Helps Eliminate Burning And Glazing Of Rubber. May Be Regritted. 5000 RPM Maximum.

Code	Description	Size	Grit
TA - 2204M - 16	Mini Wheel Rasp	1 - 1/2" X 1/8"	16
TA - 2205M - 36	Mini Wheel Rasp	1 - 1/2" X 3/16"	36
TA - 2208M - 16	Mini Wheel Rasp	1 - 1/2" X 1/2"	16
TA - 2207M - 36	Mini Wheel Rasp	1 - 1/2" X 1/2"	36
TA - 2203 - 36	Wheel Rasp	2" X 3/16"	36
TA - 2204 - 16	Wheel Rasp	2" X 3/16"	16
TA - 2205 - 36	Wheel Rasp	2" X 1/4"	36
TA - 2206 - 16	Wheel Rasp	2" X 1/4"	16
TA - 2207 - 36	Wheel Rasp	2" X 1/2"	36
TA - 2208 - 16	Wheel Rasp	2" X 1/2"	16
TA - P208 - 16	Piranha Rasp	2" X 1/2"	16
TA - 2209 - 36	Wheel Rasp	2" X 3/4"	36
TA - 2210 - 16	Wheel Rasp	2" X 3/4"	16
TA - T350 - 16	Wheel Rasp	3" X 1/2"	16
TA - T418 - 16	Wheel Rasp	4" X 1/8"	16
TA - T418 - 36	Wheel Rasp	4" X 1/8"	36
TA - T438 - 16	Wheel Rasp	4" X 3/8"	16
TA - T450 - 16	Wheel Rasp	4" X 1/2"	16
TA - T650 - 16	Wheel Rasp	6" X 1/2"	16
332056 - 36	Wheel Rasp	2" X 3/16"	36
332058 - 16	Wheel Rasp	2" X 1/4"	16
332064 - 16	Wheel Rasp	2" X 1/2"	16



DISPOSABLE TUNGSTEN CARBIDE ROUND FACED BUZZ - OUT WHEELS

Economy Tungsten Carbide Buzz-Out Wheel. Air - Cooled Design Permits Faster, Cooler And Cleaner Buffing And Helps Eliminate Burning And Glazing Of Rubber. Disposable 5000 RPM Maximum.

Code	Description	Size	Grit
21 - 101 - 36	Disposable Wheel Rasp	2" X 1/4"	36
21 - 100 - 16	Disposable Wheel Rasp	2" X 1/4"	16
21 - 105 - 36	Disposable Wheel Rasp	2" X 1/2"	36
21 - 104 - 16	Disposable Wheel Rasp	2" X 1/2"	16
21 - 107 - 36	Disposable Wheel Rasp	2" X 3/4"	36
21 - 106 - 16	Disposable Wheel Rasp	2" X 3/4"	16

TUNGSTEN CARBIDE CONES, BALLS, RODS AND SPECIALTY TOOLS

Tungsten Carbide Pencil And Cone Rasps Are Regrittable. Maximum 5000 RPM.

Code	Description	Size	Grit
DSK - 458 - 24	Ang. Disc Wheel Vent	4 X 3/4"	24
DSK - 458 - 24R	Ang. Disc Wheel Vent	4 X 3/4"	24
DSK - 738 - 16	Disc Wheel	6 - 3/4"	16
DSK - 738 - 24	Disc Wheel	6 - 3/4"	24
TA - 2505 - 36	Straight Pencil Rasp	2 - 1/2" X 1/4"	38
TA - 2507 - 36	Taper Pencil Rasp	2 - 1/2" X 1/4"	30
TA - 2508 - 16	Taper Pencil Rasp	2 - 1/2" X 1/4"	16
TA - 2506 - 16	Straight Pencil Rasp	2 - 1/2" X 1/4"	16
TA - 2612 - 16	Cone Rasp	2" X 1"	16
TA - 2613 - 36	Cone Rasp	4" X 3/4"	36
TA - 2614 - 16	Cone Rasp	4" X 3/4"	16
TA - 2200 - 16	Ball Rasp With 1/4" Shaft	7/8"	16
TA - 2200 - 36	Ball Rasp	7/8"	36
932005 - 330	Ball Rasp	5/8"	330 SSG
932004 - 330	Ball Rasp	7/8"	330 SSG
932088 - 390	NHR	1/4" X 3"	330 SSG



**TUNGSTEN CARBIDE CONTOUR CUPS**

Tungsten Carbide Contour Cup. Air - Cooled Design Permits Faster, Cooler And Cleaner Buffing. Helps Eliminate Burning And Glazing Of Rubber. 5000 RPM Maximum.

Code	Description	Size	Grit
TCW - 210 - 16	Cup Rasp	2" X 1"	16
TCW - 210 - 36	Cup Rasp	2" X 1"	36
TCW - 210 - 40	Cup Rasp	2" X 1"	40
TCW - 210 - 60	Cup Rasp	2" X 1"	60
TCW - 310 - 16	Cup Rasp	3" X 1"	16
TCW - 310 - 36	Cup Rasp	3" X 1"	36
TCW - 315 - 16	Cup Rasp	3" X 1 - 1/2"	16
TCW - 315 - 36	Cup Rasp	3" X 1 - 1/2"	36
TCW - 315 - 60	Cup Rasp	3" X 1 - 1/2"	60
TCW - 415 - 16	Cup Rasp	4" X 1 - 1/2"	16
TCW - 415 - 36	Cup Rasp	4" X 1 - 1/2"	36
TCW - 415 - 60	Cup Rasp	4" X 1 - 1/2"	60
TCW - 615 - 16	Cup Rasp	6" X 1 - 1/2"	16
TCW - 615 - 36	Cup Rasp	6" X 1 - 1/2"	36
TDW - 310 - 16	Donut Wheel Rasp	3" X 1"	16
TDW - 410 - 16	Donut Wheel Rasp	4" X 1"	16
TDW - 410 - 36	Donut Wheel Rasp	4" X 1"	36
TDW - 510 - 16	Donut Wheel Rasp	5" X 1"	16
TDW - 510 - 36	Donut Wheel Rasp	5" X 1"	36
TDW - 610 - 16	Donut Wheel Rasp	6" X 1"	16
TDW - 610 - 36	Donut Wheel Rasp	6" X 1"	36
TCW - 515 - 16	Cup Rasp	5" X 1 - 1/2"	16
TCW - 515 - 36	Cup Rasp	5" X 1 - 1/2"	36
TFW - 415 - 16	Flat Wheel	4" X 1 - 1/2"	16
TFW - 615 - 16	Flat Wheel	6" X 1 - 1/2"	16
TFW - 610 - 36	Flat Wheel	6" X 1"	36
TCW - 815 - 16	Cup Wheel	8 X 1 - 1/2"	16



TCW - 210 - 16



TCW - 210 - 60



TCW - 310 - 16



TCW - 415 - 60

TACKS, BANDS AND DISCS

Tungsten Carbide Contour Cup. Air - Cooled Design Permits Faster, Cooler And Cleaner Buffing. Helps Eliminate Burning And Glazing Of Rubber. Disposable 5000 RPM Maximum

Code	Description	Size
TBYH12	OX2 - Hub With Insert	2-1/2"
TBYH1	OX3 - Hub With Insert	1-1/2"
TBYD03	Tac-A-Disc Convex	7"
TBYOX2R	OX2R- Tack Finish Rasp	2-1/2"
TBYOX3R	OX3R - Tack Finish Rasp	1-1/2"



TBYOX2R



TBYH12



TBYD03

**POLY PLUGS FOR FLARED CONTOUR WHEELS**

Code	Description
RH122 - S - 460	Contour Wheel 3 - 1/2" S 460 3/8" Arbor Hole
RH150	1 - 3/4" Polyplug
RH151	2" Polyplug
RH152	2" 1/2" Polyplug
RH154	3" Polyplug
RH156	3 1/2" Polyplug



RH150



RH156

POLY AND ANTI-STICK FOIL

Code	Description		
IP - POLY - 12	Poly - Film 12" 250°	26Lb	Roll
IP - POLY - 15	Poly - Film 15" 250°	32Lb	Roll
IP - HTPOLY - 12	Poly - Film 12" 330°	21Lb	Roll
IP - HTPOLY - 15	Poly - Film 15" 330°	21Lb	Roll
5550	Anti - Stick Foil - 3" X 6"	1000/Box	



IP - POLY - 12

WICKING PADS AND VENT CORD

Code	Description
RWICK - 8X12	8" X 12" Retread Wick Pad With Straps
WICK - 8X15	8" X 15" Retread Wick Pad - Stretch
6 - IN	Poly Vent Cord 6" X 100 Yd



RWICK - 8X12

STAPLERS AND ACCESSORIES

Code	Description
R - 98MR1B50 - 16	Rainco Air Stapler - 50 Series
TU216 - 84B	Stanley/Bostitch Air Stapler
DWS5020	Duo Fasco Air Stapler
R - 84S5010G	Rainco 5/16" Staples 5000/Box
RP692071	OTR Delugger Blade - Carbide Tip



R - 84S5010G

RUBBER DUROMETERS

Durometer - Rubber - A - Type. Pocket Size With Large, Easy-To-Read Dial. Measures The Hardness Of Rubber By The Deflection Of A Steel Probe In The Material.

Code	Description
46 - 728	Durometer - Rubber - A - Type



R - 98MR1B50 - 16

**BUFFING BLADES AND ACCESSORIES**

Code	Description
RP692071	OTR Delugger Blade - Carbide Tip
APOLLO - II	Apollo II Buffing Refills
PC - ULTRA - I	Ultra I Buffing Blades - Pincott
PC - ULTRA - II	Ultra II Buffing Blades - Pincott
PC - ULTRA - III	Ultra III Buffing Blades - Pincott
APOLLO - II DET	Apollo II DET Buffing Refills
APOLLO - III	Apollo III Buffing Refills
R4 - 20	R - 4 - 20 Buffing Refills
R4 - 25	R - 4 - 25 Buffing Refills
PC - R4 - 25	Pincott R4 - 25 Rasp Blade 28ST
PC - P3 - 20	Pincott P3 - 20 Rasp Blade
R105 - 22	R105 - 22 Buffing Refills
R115 - 20	R115 - 20 Buffing Refills
PC - R115 - 20	Pincott R115 - 20 Rasp Blade 25ST
R115 - 25	R115 - 25 Buffing Refills
R115SB - 25	R115 - 25 Switch Blade Buffing Refill
S - 115 - 20	S - 115 - 20 Buffing Refills
S - 115 - 25	S - 115 - 25 Buffing Refills
PATRIOT - MI	Patriot MI Mulcher Blades
EAGLE - II	Eagle II Buffing Refills
19 - 200	Rasp Sharpener - Replacement Cartridge 12 Pack
57 - S	Rasp Sharpener With Handle
S2S16	Saturn 2 Spacer 3/16"
16 - 630	Saturn 2 Outer Support Spacer 8/Pack
S2S8	Saturn 2 Spacer 3/8"
S3S16	Saturn 3 Spacer 3/16"
S3S8	Saturn 3 Spacer 3/8"
S2P3	Saturn 2 Pins 3 - 3/4"
16 - 438	Saturn 3 Buff - 5/16" X 8" Pin
16 - 512	R - 115 Hub - Spacer 3/8"
16 - 511	R - 115 Hub - Spacer 1/4"
16 - 510 - 1	R - 115 Hub - Spacer 3/16"
16 - 436	SIO Buffer - 5/16" X 4" Pin
111205	Saturn 3 - Pin 5/16" Dia X 3 - 3/4"
111463	Saturn 3 - 1/4" Air Spacer Aluminum Beam
12 - 957	Saturn 2 AP Hub Complete
12 - 921	Saturn 2 AP Hub Complete
TI95	TSI Tire Inspector - Expandable Hub
729617	Plain Stem - Expandable Hub
729618	Locking Stem - Expandable Hub
900512	Garter Spring - Expandable Hub
600846	Expandable Rim Assembly 22 - 24.5 X 9"
R600846M	Mich. Expandable Hub Assembly 22 - 24.5 X 9"
733093	Expandable Rim Assembly 22 - 24.5 X 8 - 1/4"
R733001	Expandable Hub Spray - 10 oz Can
EHL - 32	RTU Expandable Hub Spray - 32oz
R732774	National 17 - 20 X 8 1/2" Expandable Hub Assembly
42 - 703	Tread cut Blade 6" X 1/8" 1 - 3/4" Arbor Hole



R115 - 20



APOLLO - II



R4 - 20

R115 - 25



S - 115 - 20



16 - 630



R4 - 25



S2P3



S - 115 - 25



R733001



900512



57 - S

**GRINDING ADAPTERS, COUPLERS AND NIPPLES**

Code	Description
S1040	#270 Quick Change Adapter
SLP - 9214	3/16" Adapter With Set Screw
S1041	#271 Quick Change Adapter
SLP - 9216	5/16" Adapter With Set Screw
S1041/38	#271/38 And #272 Adapter
S1043	1/8" Quick Change Adapter
SLP - 9213	1/8" Adapter With Set Screw
S1044	1/4" Quick Change Adapter
SLP - 9215	1/4" Adapter With Set Screw
S1046	Short Arbor
SLP - 9211	3/8" - 24 Quick Change Adapter 1 - 7/8"
S1046D	Dual Flip Adapter
S1047	Long Arbor
SLP - 9212	3/8" - 24 Quick Change Adapter 2 - 1/4"
S1047XL	Quick Change Extra Long Adapter
S1048	Short Arbor 1 - 3/4"
SLP - 9201	3/8" - 24 Jacobs Chuck Adapter 1 - 11/16"
S1049	Long Arbor 2 - 7/8"
SLP - 9202	3/8" - 24 Jacobs Chuck Adapter 2 - 3/4"
PJN	Nut For S1049 Series Adapter
SLP - 5005	Adapters - Allen Screw



S1040



S1041



S1046D



SLP - 9202



PJN



54 - 510



SLP - 9201



3500



C - 2



K - 2

RETREADING COUPLERS AND ADAPTERS

54 - 512	Band AG Type Coupler St2 - Bd
54 - 510	Band AG Envelope Plug With Gasket
874 - 6	Baird Straight Through 90D Coupler
TW - 12	Teflon Gasket - Band . Envelope Plug
2013/PRESTI	Envelope Adapter Sureseal .482
2010	Envelope Valve

WYCO FLEX - SHAFT SYSTEM TOOLS AND ACCESSORIES

Code	Description
49 - 2	Wyco Flex Shaft 1/3 HP 1725 RPM
49 - 3	Wyco Flex Shaft 1/2 HP 3450 RPM
49 - 5	Wyco Flex Shaft 3/4 HP 3450 RPM
C - 2	C - 2 Core
C - 10	C - 10 Core
C - 30	C - 30 Core
K - 2	K - 2 Casing
K - 10	K - 10 Casing
K - 30	K - 30 Casing
551	551 Handpiece
3500	3500 Handpiece
3400 - 1/2	3400 - 1/2" Motor Coupling
3400 - 5/8"	3400 - 5/8" Motor Coupling
550MP - 5/8"	550MP - 5/8" Motor Coupling
550MP - 3/4"	550MP - 3/4" Motor Coupling
305	305 Adapter
305 - R	305 - R Adapter
655 - 143	Wyco Flex Shaft Grease - 14oz
405	405 Adapter



305 - R



3400 - 5/8"



K - 10



405



K - 2

**REMA TIP TOP OTR VULCANIZING SYSTEMS AND ACCESSORIES**

Code	Description
6580	EMTP - I Thermopress Machine
6700	EMTP - II Thermopress Machine With Stand
6595	EMTP - III Thermopress Machine
6585	EM Tire Lifter



6580

MONARCH VULCANIZING SYSTEMS PARTS AND ACCESSORIES*Monarch OTR Control Panel, Heat Pads and Accessories*

Code	Description	Size
M100	Monarch OTR Control Panel	
MVN100	Monarch Control Panel With O Timer	
TROC5XL	Monarch OTR Comp.Harness - 5 Strap	
TROC4	Monarch OTR Comp.Harness - 4 Strap	
MVS9001 - 100	Monarch Cyl. Air Bag Gauge 0 - 60	
M45/6	Monarch Standard OTR Harness Straps	
M45/6/7	Monarch Ext.OTR Harness Straps	
M2519H	Monarch OTR Heat Pad	25" X 19"
M3015H	Monarch OTR Heat Pad	30" X 15"
M2621H	Monarch OTR Heat Pad	26" X 21"
M2626H	Monarch OTR Heat Pad	26" X 26"
TR2213H	Monarch OTR Heat Pad	22" X 13"
TR2210H	Monarch OTR Heat Pad	22" X 10"
M4220H	Monarch OTR Heat Pad	42" X 20"
M4824H	Monarch OTR Heat Pad	48" X 24"
M3132H	Monarch OTR Heat Pad	31" X 32"
TR2621H	Monarch TR Heat Pad	26" X 21"
TR2621 - OC	TR2621 Outer Cover Only	
TR1315 - 20W	Monarch TR Cyl. Air Bag	13" X 15" X 20"
M1518 - 24W	Monarch TR Cyl. Air Bag	15" X 18" X 24"
M1721 - 24W	Monarch TR Cyl. Air Bag	17" X 21" X 24"
TR911 - 13W	Monarch TR Cyl. Air Bag	9" X 11" X 13"
TR2213E	Monarch Ext.Curing Pack	22" X 13"
TR2621E	Monarch Ext Cure Pack	26" X 21"
M2732/32W	Monarch TR Cyl Air Bag	27" X 32"
M3336/32W	Monarch TR Cyl Air Bag	33" X 36"
M3842/32W	Monarch TR Cyl Air Bag	38" X 42"
M4824	Monarch Flat Air Bag	48" X 24"
M4447/32W	Monarch TR Cyl Air Bag	44" X 47"
M4824W	Monarch Flat Window Air Bag	48" X 24"
M3638	Monarch Flat Air Bag	36" X 38"
M1820	Monarch Flat Air Bag	18" X 20"
M2424	Monarch Flat Air Bag	24" X 24"
M3536	Monarch Flat Air Bag	35" X 36"
M3624	Monarch Flat Air Bag	36" X 24"
M3541	Monarch Flat Air Bag	35" X 41"
M2828	Monarch Flat Air Bag	28" X 28"
M5432W	Monarch Flat Air Bag	54" X 32"
M6032	Monarch Flat Air Bag	60" X 32"
M6732W	Monarch Flat Air Bag	67" X 32"
M7532W	Monarch Flat Air Bag	75" X 32"
M4832E	Monarch Ext.Curing Pack	48" X 32"
M7232	Monarch Flat Air Bag	72" X 32"
M9032W	Monarch Flat Air Bag	90" X 32"



MVN100



VULCAN - VULCAP REPLACEMENT HEAT PADS, CYLINDERS AND AIRBAGS

Monarch Heat Pads, Cylinders and Air Bags

Code	Description	Size	Volts
VV - 2815H	Monarch Inside Heat Pad	28" X 15"	
VV - 2215H	Monarch Outside Heat Pad	22" X 15"	
VV - 2621H	Monarch OTR Heat Pad	26" X 21"	220V
VV - 1721/24CAB	Monarch TR Cyl Air Bag	17" X 21"	

VULCAN - VULCAP REPLACEMENT HEAT PADS, CYLINDERS AND AIRBAGS

Monarch Heat Pads, Cylinders and Air Bags

Code	Description	Size
VV - 2621HGB	Mono Flat Air Bag	26" X 21"
VV - 4824FAB	Mono Flat Air Bag	48" X 24"

SMR REPLACEMENT HEAT PADS, CYLINDERS AND AIRBAGS

External Thermocouple Heat Pad 15"X 24" 220 Volt Sand M

Code	Description	Size
SMR - 1524H	Mon OTR Heat Pad	15" X 24"
SMR - 1818H	Mon OTR Heat Pad	18" X 18"
SMR - M2519H	Mon OTR Heat Pad	25" X 19"
SMR - 2828H	Mon OTR Heat Pad	28" X 28"
SMR - TR2213H	Mon OTR Heat Pad	22" X 13"
M2836H	Mon OTR Heat Pad	28" X 36"
SMR - M3015H	Mon OTR Heat Pad	30" X 15"
SMR - M4215H	Mon OTR Heat Pad	42" X 15"
SMR - M4220H	Mon OTR Heat Pad	42" X 20"
SMR - M4824H	Mon OTR Heat Pad	48" X 24"
SMR - M3132H	Mon OTR Heat Pad	31" X 32"
SMR - TR2621H	Mon TR Heat Pad	26" X 21"
SMR - M1721 - 24W	Mon TR Cyl Air Bag	17" X 21" X 24"
SMR - TR2621AB	Mon TR Air Bag	26" X 21"
SMR - M2732/32W	Mon TR Cyl Air Bag	27" X 32" X 32"
SMR - M4447/32W	Mon TR Cyl Air Bag	44" X 47" X 32"
SMR - M4824W	Mon Flat Air Bag	48" X 24"
SMR - M4824W	Mon Flat Air Bag	54" X 32"
SMR - M5432W	Mon Flat Air Bag	67" X 32"
SMR - M6732W	Mon Extension Curing Pack	48" X 32"
SMR - M4832E	Mon Flat Air Bag	90" X 32"
SMR - M9032W		



V - 1002809

GVS EQUIPMENT PARTS AND ACCESSORIES

Code	Description	Size
V - 1002819	GVS Heat Pad	12" X 12"
V - 1002809	GVS Heat Pad	8" X 8"
V - 1002829	GVS Heat Pad	14" X 14"
V - 1002789	GVS Heat Pad	6" X 7"
V - 1002869	GVS Air Bag	12" X 12"
V - 1002889	GVS Air Bag	14" X 14"
V - 1002929	GVS Air Bag	6" X 7"
V - 1002859	GVS Air Bag	8" X 8"
V - 1002919	GVS Air Bag - Round	20" X 20"
V - 1002849	GVS Heat Pad - Round	20" X 20"



V - 1002919



VULCANIZERS PASSENGER, TRUCK AND AGRICULTURAL

Code	Description
S1015	300 Tubeless Plate - Passenger
S1016	400 Truck Tire Vulcanizer
S1017	500 Large Tire Spotter
S1018	1000 Tractor Tire Spotter
S1022A	Model Light Passenger/Light Truck Spotter
S1021	1400 Tractor Small Air Vulcanizer
S1019	GT2B Giant Tire Vulcanizer
S1025	Truck Tire Bead Spotter
S1028	Model 2000TS Truck Spotter
S1028 - STD	Stand For Model 2000TS Spotter
S1030	2500 Multi Use Tire Vulcanizer
S1023A	Model MT Medium Truck Spotter
T035	Heat Unit For Model 150 T002
T036	Heat Unit For Model 200 T003
P45	4" Outside Shoulder Curing
P48	4" Inside Contour Adapter
P49	4" Outside Contour Adapt
P58	5" Inside Contour Adapter
P58A	5" Contour Adapter - Flat
P59	5" Outside Shoulder Curing
PL1	L1 Outside Tractor Plate 4" X 5"
PR1	R1 Inside Tractor Plate 4" X 5"
PP1	P1 Flat Plate - Use With T095 Bag
T095	Pliable Contour Bag T095
T096	Pliable Contour Bag T096
P43	Upper Heat Unit T039
P44	Lower Heat Unit T038
P1004	Lower Fixed Heat Unit T044
PG103	Upper Swivel Heat Unit T045
PG104	Lower Heat Unit T046
PAS - 3 - 120	Upper Swivel Heat Unit
PAS - 4 - 120	Silicone Rubber Heat Pad 120V T051
T023	Model LT - Upper Heat Unit
PAS - 3 - 16 - 12	Inside Heat Unit With Shaft T056
PAS - 4 - 16 - 12	Silicone Rubber Heat Pad T057
PAS - 5 - 16	Silicone Rubber Air Seal T063
T047	Linc 3100 - Outer Heat Unit Swivel
T048	Linc 3100 - Inside Heat Unit - Fixed
5175260	Heat Mat #5
5176276	#4 Pocket For Heat Mat
5175246	#4 Heat Mat



S1017



S1015



PAS - 3 - 16 - 12



PAS - 4 - 16 - 12



PG104



T047



T048



S - 180

AIR POWERED EXTRUDER GUNS

Code	Description
S - 180	6792 Bench Top Nail Hole Extruder 110V
S - 182	6790 Mini Extruder - 110V



Wheel Service Tools And Accessories



Magnum

PLUS

The better tire balancing compound

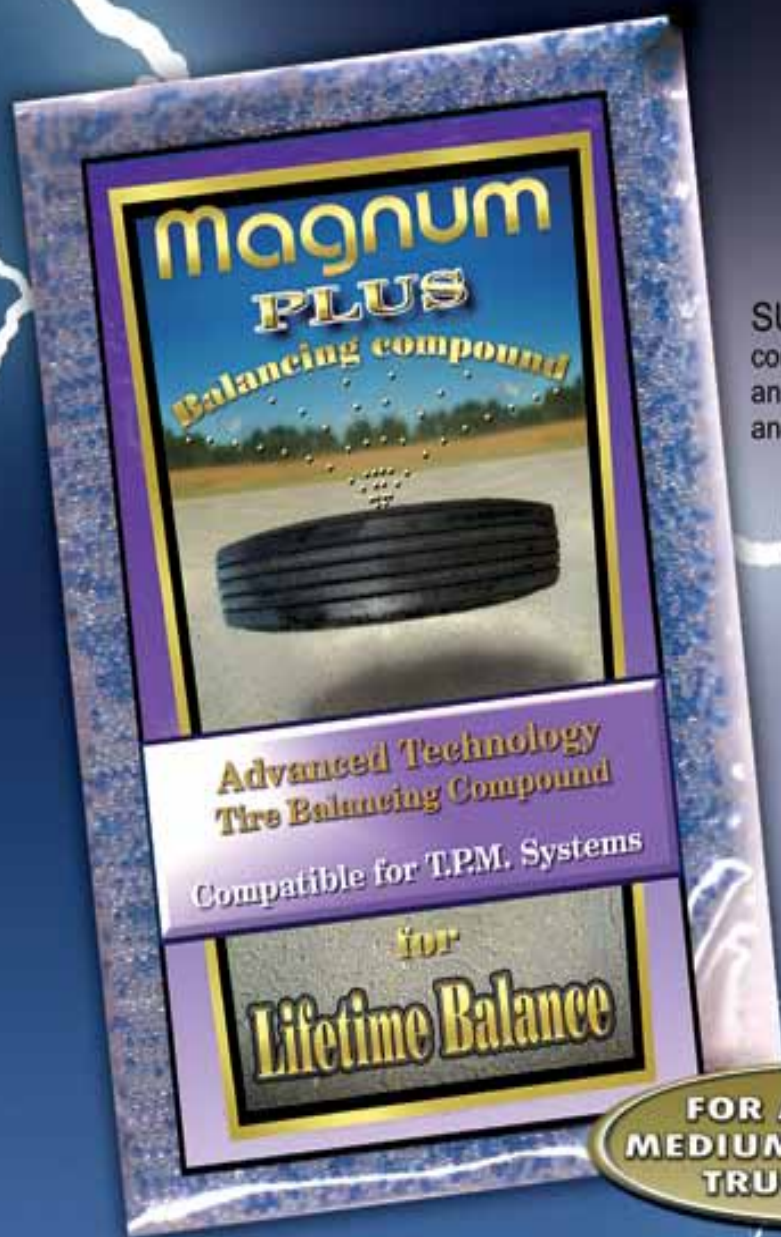

SUPER-FLOWABILITY - Magnum Plus consists of specially-coated superbeads that give an optimum balance to light and medium truck tires and is TPMS compatible.

NO STATIC - No static build-up ensures maximum flowability.

LONG-LASTING - Magnum Plus is durable and can be re-used in trailer tires.

ECONOMICAL - Magnum Plus saves you money by eliminating the need to re-balance your tires at regular intervals.

**FOR ALL YOUR
MEDIUM AND LIGHT
TRUCK TIRES**

www.magnumbalance.com 1-800-569-0337 mail@magnumbalance.com



RIM PROTECTION AND WHEEL GUARDS

Lok - Air, Air Guard Is A Specially Formulated Light Viscosity Fluid. Stops Rust Build - Up And Provides A Protective Coating On Rims And Inner Liners. Assists In Cooling Tire Heat Build - Up.

Code	Description
2020 - 1	Lok - Air Guard Rim Protection 1L
2020 - 5	Lok - Air Guard Rim Protection 5G



2020 - 1

Tire Life 20 Oz. Bag. Reduces Bead Brittleness, Liner Oxidation And Controls Belt And Rim Rust. Greatly Improves Long Term Air Retention. Helps Tire To Run Cooler Which Increases Tread Life.

Code	Description
TL20 - 40	Tire Life 20 oz. Bag



TL20 - 40

WHEEL GUARDS

Code	Description	Stud Hole	Bolt Diameter
60100 - 5901	Wheel Guard 10 Hole	1 - 1/8" And 7/8"	11 - 1/4"
60101 - 5902	Wheel Guard 10 Hole	3/4"	11 - 1/4"
60102 - 5903	Wheel Guard 10 Hole	22 mm	285 mm
60104 - 7381	Wheel Guard 10 Hole	22 mm	335 mm
60105 - 7902	Wheel Guard 8 Hole	20 mm	275 mm
60108	Wheel Guard 8 Hole Ford	5/8"	225 mm
60106	Wheel Guard GM And Dodge	5/8"	170 mm
60107	Wheel Guard 8 Hole Ford	5/8"	170 mm



60100 - 5901



60104 - 7381

Disc Wheel Measuring Tool Kit That Shows You When Wheel Inner And Outer Cap Nuts Are Worn. Designed For Use With Stud Piloted Steel Wheels Which Have .875R Spherical Bolt Holes 3/8" To 1/2" Disc Thickness.

Code	Description
AME - 69290	CGH - 10 Wheel Nut Chamfer Gauge



AME - 69290

PORTABLE WORK LIGHT

Designed For Hands - Free Lighting During Tire Service And Other Work Applications. 12" Adjustable Spring - Tube For Optimum Light Positioning Within Tight Places Compact High - Power Led Provides Up To 300 Lux For Intense Focus And Optimum Visibility. Clamp - On Handle Quickly And Easily "Grips" Over The Bead Of A Tire For Complete Hands - Free Light Assistance. Compatible With All Passenger, Light Truck, And Co Mmercial Truck Tires Compatible With All Tire Spreaders Multiple High - Power Magnets On The Handle And Light Head Attach Easily To Most Metal Surfaces. Unique Design Provides Unlimited Vehicle Service And Work Applications. Lithium - Ion Rechargeable Batteries.

Code	Description
AME - 73210	Portable Automotive Light - Pal



AME - 73210



RIM PROTECTION AND WHEEL GUARDS

Deluxe Chrome Wheel Rim Guard. Protects Aluminum, Chrome And Painted Truck Rims Or Wheels During Stud And Nut Removal.

Code	Description
50303	Heavy Duty Chrome Wheel Rim Guard



50303

Chrome Wheel Rim Guard. Protects Aluminum, Chrome And Painted Truck Rims Or Wheels During Stud And Nut Removal.

Code	Description
50301	Standard Chrome Wheel Rim Guard

Chrome Wheel Shield. Protects Aluminum, Chrome And Painted Truck Rims Or Wheels During Manual Mounting/Demounting. Protects Wheel From Floor.

Code	Description
AME - 52000	Chrome Wheel Shield Snap - In



AME - 52000

TRUCK WHEEL NUTS

Code	Description
891AR	Outer Cap Nut - Steel And Aluminum Right Thread
892AL	Outer Cap Nut - Steel And Aluminum Left Thread
896R	Standard Inner Cap Nut - Steel Wheels Right Thread
896L	Standard Inner Cap Nut - Steel Wheels Left Thread
988R	Standard Inner Cap Nut - Steel Wheels Right Thread
988L 708AR	Standard Inner Cap Nut - Steel Wheels Left Thread
897R	Inner Cap Nut Thread - 1 - 7/8" - 16 R
897L	Inner Cap Nut Thread - 1 - 7/8" - 16 L
306R	Metric Inner Cap Nut - R Zinc
306L	Metric Inner Cap Nut - L Zinc
304R	Metric Outer Cap Nut - R Zinc
304L	Metric Outer Cap Nut - R Zinc
709AL	M 22" X 1.5" Flange Cap Nut Hex
333B	M 22" X 1.5" Flange Cap Nut Hex
333B - BULK	M 22" X 1.5" Flange Cap Nut Hex
881M	M 20" X 1.5" Flange Cap Nut Hex
919SI	M 22" X 1.5" Flange Cap Nut Hex
920SI	M 22" X 1.5" Flange Cap Nut Hex
716SI	Flat Face Lug Nut - 3/4" - 10 Thread
716SI - BULK	Flat Face Lug Nut - 3/4" - 10 Thread



708AR



920SI



896R



881M



988R



716SI



333B



SN - M22



891AR

Skirt Nut M22" x 1.5 - HEX Cap. This Replaces Standard M22 Flange Nuts On 11.25" Hub Piloted Wheels. The Skirt Nut Partially Penetrates The Stud Hole And Prevents The Clocking Action That Contributes To Elongated Bolt Holes And Wheel - Offs

Code	Description
SN - M22	Skirt Nut - M 22" x 1.5 - HEX 33 mm

Used During The Installation Of Aluminum Rim And Tire Assembly. Use Of Guides Will Ensure Rim Is Centred. Improves Runout, Balance And Vibration Problems.

Code	Description
RCG - AL	Aluminum - Rim Centre Guides



RCG - AL



TRUCK WHEEL STUDS

Code	Description	Size
715SI	Lug Stud 3/4" - 10 T Heavy Duty. X 2	15/16"
715SI - BULK	Lug Stud 3/4" - 10 T Heavy Duty. X 2	15/16"
436SI	Wheel Stud - M22" X1.5 T Heavy Duty - 4	15/32"
439SI	Wheel Stud 3/4" - 16 T Heavy Duty 2"	23/32"
654	5/8" - 11 T Heavy Duty X 2 - 3/4" Dayton Stud	
160SI	M22" X1.5 T Heavy Duty 4 - Wheel Stud	25/32"
162S	M22" X1.5 T Heavy Duty 3 - Wheel Stud	15/16"
164SI	M22" X1.5 T Heavy Duty Wheel Stud 3 - 1/2"	
437SI	Wheel Stud - M22" X1.5 Theavy Duty - 5	11/32"
418	3/4" - 16 Thread Wheel Stud	3 - 3/16"
419	3/4" - 16 Thread Wheel Stud	3 - 3/16"



TRUCK WHEEL CLAMPS

Code	Description
722SI	3/4" - 1/2" Gunite Rim Clamp
993SI	3/4" - 1 - 1/2" Dayton Rim Clamp
123	3/4" - 1 - 1/8" Dayton Rim Clamp
235	3/4" - 1 - 3/4" Dayton Rim Clamp
149	5/8" - 11 - 1 - 1/16" Dayton Wheel Nut



Uni - Mount Thread Gauge. Designed For M22" x 1.5 Uni - Mount Studs. If Thread Teeth Do Not Fully Engage The Stud, The Stud Should Be Removed From Service.

Code	Description
AME - 69260	Uni - Mount Thread Gauge

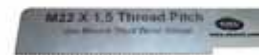

AME - 69260

DECORATIVE WHEEL COVERS

22.5" / 24.5" 10 - Hole Front Wheel Covers. This Complete Kit Is Set Up For 33 mm Lug Nuts, Hub Piloted Wheel With A .285 Bolt Pattern.

Code	Description
H - 076188B	22.5" / 24.5" 10 - Hole Front Wheel Covers



H - 076188B

22.5" / 24.5" 10 - Hole Back Wheel Covers. This Complete Kit Is Set Up For 33 mm Lug Nuts, Hub Piloted Wheel With A .285 Bolt Pattern.

Code	Description
H - 077188B	22.5" / 24.5" 10 - Hole Back Wheel Covers



H - 077188B



TRUCK WHEEL ALIGNMENT

Kenworth Shim

Code	Description	Pack
35001	Kenworth Shim 1/32	6
35002	Kenworth Shim 1/16"	6
35003	Kenworth Shim 1/8"	6
35004	Kenworth Shim 1/4"	6
35005	Kenworth Shim 1/2"	6
35006	Kenworth Shim 3/4"	6
35007	Kenworth Shim 1"	6

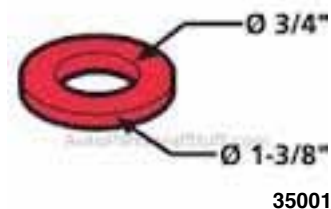

Peterbilt Shim

Code	Description	Pack
35010	Peterbilt Shim 1/32"	6
35011	Peterbilt Shim 1/16"	6
35012	Peterbilt Shim 1/8"	6

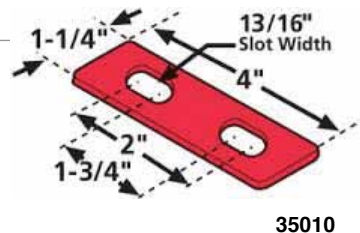

Freightliner Shim

Code	Description	Pack
35020	Freightliner Shim 1/32"	6
35021	Freightliner Shim 1/16"	6
35022	Freightliner Shim 1/8"	6

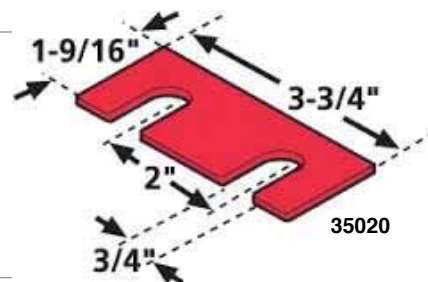

Volvo Shim

Code	Description	Pack
35030	Volvo/Weight Shim 1/32"	6
35031	Volvo/Weight Shim 1/16"	6
35032	Volvo/Weight Shim 1/8"	6

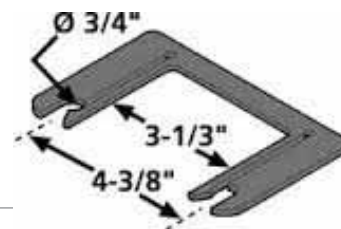

Tandem Shim

Code	Description	Pack
35040	Tandem Shim - IHC 1/32"	6
35041	Tandem Shim - IHC 1/16"	6
35042	Tandem Shim - IHC 1/8"	6
35060	Tandem Shim Freightliner SS 1/32"	6
35061	Tand Shim - Freightliner SS 1/16"	6
35062	Tand Shim - Freightliner SS 1/8"	6

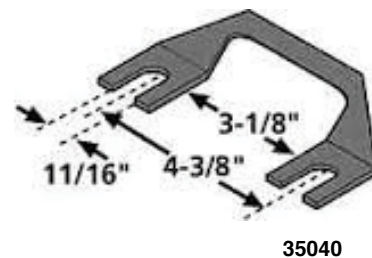

P/K Shim

Code	Description	Pack
36001	P/K Thrust Shim 1/32"	6
36002	P/KThrust Shim 1/16"	6
36003	P/K Thrust Shim 1/8"	6

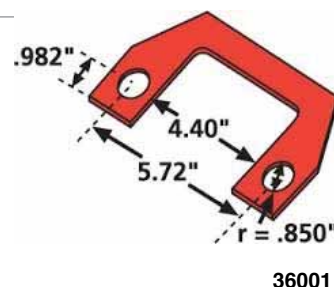



TRUCK WHEEL ALIGNMENT

Flex - Air Shim

Code	Description	Pack
36010	Flex - Air Heavy Duty Shim 1/32"	6
36011	Flex - Air Heavy Duty Shim 1/16"	6
36012	Flex - Air Heavy Duty Shim 1/8"	6

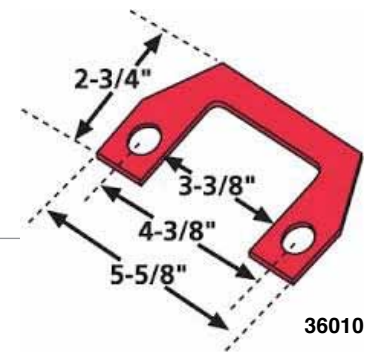

Navistar Shim

Code	Description	Pack
36020	Navistar Heavy Duty Shim 1/32"	6
36021	Navistar Heavy Duty Shim 1/16"	6
36022	Navistar Heavy Duty Shim 1/8"	6

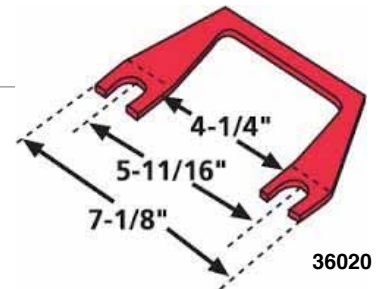

Hendrickson Shim

Code	Description	Pack
36080	Hendrickson Heavy Duty Shim	2
36085	Hendrickson Heavy Duty Shim	2



Aluminum Shim

Code	Description	Pack
10612	Aluminum Ax Shim 3.5" X 1D X 6.25"	6
10705	Aluminum Ax Shim 4" X 0.5D X 6.5"	6
10712	Aluminum Ax Shim 4" X 1.0D X 6.5"	6
10722	Aluminum Ax Shim 4" X 1.5D X 6.5"	6
10732	Aluminum Ax Shim 4" X 2.0D X 6.5"	6
10742	Aluminum Ax Shim 4" X 2.5D X 6.5"	6
10752	Aluminum Ax Shim 4" X 3.0D X 6.5"	6





TRUCK WHEEL ALIGNMENT

Bronze Shim

Code	Description	Pack
10704	Bronze Ax Shim 4" X 0.5" D X 6.5" 6	6
10714	Bronze Ax Shim 4" X 1.0" D X 6.5" 6	6
10724	Bronze Ax Shim 4" X 1.5" D X 6.5 6	6
10734	Bronze Ax Shim 4" X 2.0" D X 6.5 6	6
10744	Bronze Ax Shim 4" X 2.5" D X 6.5 6	6
10754	Bronze Ax Shim 4" X 3.0" D X 6.5 6	6
10614	Bronze Ax Shim 3.5" X 1" D X 6.25 6	6



10704

Zinc Shim

Code	Description	Pack
10703	Zinc Shim 4" X 0.5" D X 6.5"	6
10713	Zinc Shim 4" X 1.0" D X 6.5"	6
10723	Zinc Shim 4" X 1.5" D X 6.5"	6
10733	Zinc Shim 4" X 2.0" D X 6.5"	6
10743	Zinc Shim 4" X 2.5" D X 6.5"	6
10753	Zinc Shim 4" X 3.0" D X 6.5"	6
10613	Zinc Ax Shim 3.5" X 1" D X 6.25" 6	6



10703

Heavy Duty Zinc Alloy Uni - Wedge Shim - 3" Or 3 - 1/2" Or 4" Width. Twice The Coverage - Half The Inventory. Changes Caster Positive Or Negative. Applications Are For Any Solid Axle 2WD Or 4WD Vehicle.

Code	Description
89199	Heavy Duty Zinc Uni - Wedge Shim - 1/2" Degree
89299	Heavy Duty Zinc Uni - Wedge Shim - 1" Degree
89399	Heavy Duty Zinc Uni - Wedge Shim - 1 - 1/2" Degree
89499	Heavy Duty Zinc Uni - Wedge Shim - 2" Degree
89599	Heavy Duty Zinc Uni - Wedge Shim - 2 - 1/2" Degree
89699	Heavy Duty Zinc Uni - Wedge Shim - 3" Degree
89799	Heavy Duty Zinc Uni - Wedge Shim - 3 - 1/2" Degree
89899	Heavy Duty Zinc Uni - Wedge Shim - 4" Degree



89199

Mercedes Wheel Spreader. Takes The Play Out Of Front Wheels During Alignment. Place Spring - Loaded Pressure Bar Between The Tires To Assure A More Accurate Alignment.

Code	Description
99918	Mercedes Wheel Spreader



99918

PASSENGER WHEEL ALIGNMENT

For Replacement Of Various Bolts. Will Allow Both Positive And Negative Camber Changes Up To Approximately 1.75 Degrees By Replacing The Upper OE Strut/Spindle Bolt

Code	Description
81240	EZ Cam ER - 10 mm Bolt - Pair
81250	EZ Cam ER - 12 mm Bolt - Pair
81260	EZ Cam ER - 14 mm Bolt - Pair
81270	EZ Cam ER - 15 mm Bolt - Pair
81280	EZ Cam ER - 16 mm Bolt - Pair
81290	EZ Cam ER - 17 mm Bolt - Pair



81250

PASSENGER WHEEL ALIGNMENT

Focus, Mazda 3 Rear Camber Arm. Adjusts From - 1.5 Deg To +5.0 Deg. Applications Include 2000 And Up Ford Focus, 2004 And Up Mazda 3, 2006 And Up Mazda 5 And 2004 And Up Volvo S40 Or V50.

Code	Description
67420	Focus, Mazda 3 Rear Camber Arm



67420

Honda Civic Camber Arm For 2006 And Up Civic, Civic Si And Hybrid. Offers Plus/Minus 3 Deg. Camber Change.

Code	Description
67470	Honda Civic Camber Arm - 2006 And Up



67470

Universal Spring Compressor. Great Option For Macpherson Strut, Coilover And Other Accessible Springs. Use Of Both Hooks Per Spring Is Required.

Code	Description
40260	Universal Spring Compressor



40260

Ford Adjustable Cam / Nut Bracket. These Are Sold As A Single Set So You Would Need One 86250 Set Per Tire.

Code	Description
86250	Ford Adjustable Cam / Nut Bracket



86250

WHEEL INDICATORS

Safety Lug Lock.

Code	Description
AME - 62600	Zafety Lock
AME - 62610	Zafety Lock With 3 - 1/2" Spacer White
AME - 62955	Zafety Lock Install / Removal Tool



Checklink Yellow Wheel Nut Retainer Link.

Code	Description	Size
CLFY19	Checklink	19 mm
CLFY24	Checklink	24 mm
CLFY27	Checklink	27 mm
CLFY30	Checklink	30 mm
CLFY32	Checklink	32 mm
CLFY33	Checklink	33 mm



CLFY19

Checklock Wheel Nut Retainer Link.

Code	Description	Size
CLS27	Checklock - S	27 mm
CLS30	Checklock - S	30 mm
CLS32	Checklock - S	32 mm
CLS33	Checklock - S	33 mm



CLS27



CHECKPOINT

Checkpoint® Yellow Loose Wheel Nut Indicators. Used Primarily To Give Users Improved Visibility Of Nut Loosening Or Prevention Of Safety Critical Issues Such As Loose Vehicle Wheels Or Structural Weaknesses Where Nuts Have Been Used As Core To The Design.

Code	Description	Size
CPY17	Checkpoint	17 mm
CPY18	Checkpoint	18 mm
CPY19	Checkpoint	19 mm
CPY20	Checkpoint	20 mm
CPY21	Checkpoint	21 mm
CPY22	Checkpoint	22 mm
CPY23	Checkpoint	23 mm
CPY24	Checkpoint	24 mm
CPY25	Checkpoint	25 mm
CPY26	Checkpoint	26 mm
CPY27	Checkpoint	27 mm
CPY28	Checkpoint	28 mm
CPY29	Checkpoint	29 mm
CPY30	Checkpoint	30 mm
CPY31	Checkpoint	31 mm
CPY32	Checkpoint	32 mm
CPY33	Checkpoint	33 mm
CPY34	Checkpoint	34 mm
CPY35	Checkpoint	35 mm
CPY36	Checkpoint	36 mm
CPY38	Checkpoint	38 mm
CPY40	Checkpoint	40 mm
CPY41	Checkpoint	41 mm
CPY46	Checkpoint	46 mm



CPY17



CPY46



CPY32

Checktorque Red Wheel Nut Retorque Indicators

Code	Description	Size
CTR17	Checktorque	17 mm
CTR18	Checktorque	18 mm
CTR19	Checktorque	19 mm
CTR20	Checktorque	20 mm
CTR21	Checktorque	21 mm
CTR22	Checktorque	22 mm
CTR23	Checktorque	23 mm
CTR24	Checktorque	24 mm
CTR26	Checktorque	26 mm
CTR27	Checktorque	27 mm
CTR28	Checktorque	28 mm
CTR29	Checktorque	29 mm
CTR30	Checktorque	30 mm
CTR31	Checktorque	31 mm
CTR32	Checktorque	32 mm
CTR33	Checktorque	33 mm
CTR34	Checktorque	34 mm
CTR36	Checktorque	36 mm
CTR38	Checktorque	38 mm
CTR40	Checktorque	40 mm
CTR41	Checktorque	41 mm



CTR17



CTR33



CTR31



DUSTITE

Dustite Commerical Vehicle Wheel Nut Dust Cap Indicators. Primarily For Use On Steering Axles Where Wheel Trims Have Been Fitted.

Code	Description
DTLRR19	Dustite 19 mm Long Reach Red
DTLRR32	Dustite 32 mm Long Reach Red
DTLRR33	Dustite 33 mm Long Reach Red
DTLRSG32	Dustite 32 mm Long Reach Silver Grey
DTLRSG33	Dustite 33 mm Long Reach Silver Grey
DTLRY19	Dustite 19 mm Long Reach Yellow
DTLRY32	Dustite 32 mm Long Reach Yellow
DTLRY33	Dustite 33 mm Long Reach Yellow



DTLRY19



DTLRR32

Checkpoint Hi - Heat Solid Orange. The Meltpoint Is An Extemely High 160 Centigrade.

Code	Description
CPSO31	CP31 mm Hi - Heat 160 C Meltpoint
CPSO33	CP33 mm Hi - Heat 160 C Meltpoint
CPSO38	CP38 mm Hi - Heat 160 C Meltpoint



CPSO33

Dustite Combined Loose Wheel Nut Indicator And Dust Cap.

Code	Description
DTR27	Dustite 27 mm Red
DTR28	Dustite 28 mm Red
DTR30	Dustite 30 mm Red
DTR32	Dustite 32 mm Red
DTR33	Dustite 33 mm Red
DTR38	Dustite 38 mm Red
DTSG27	Dustite 27 mm Silver Grey
DTSG28	Dustite 28 mm Silver Grey
DTSG30	Dustite 30 mm Silver Grey
DTSG32	Dustite 32 mm Silver Grey
DTSG33	Dustite 33 mm Silver Grey
DTSG38	Dustite 38 mm Silver Grey
DTY27	Dustite 27 mm Yellow
DTY28	Dustite 28 mm Yellow
DTY30	Dustite 30 mm Yellow
DTY32	Dustite 32 mm Yellow
DTY33	Dustite 33 mm Yellow
DTY38	Dustite 38 mm Yellow



DTR33



DTR32



DTY32

ROLLOCK

Rollock Wheel Nut Lock. Requires The 62550 Rollock Installation Tool To Apply.

Code	Description
AME - 62500	Rollock 3 - 1/2" Spacing 30 - 33 mm
AME - 62000	Rollock 4 - 1/8" Spacing 30 - 33 mm
AME - 62550	3 - 1/2" Rollock Install Tool
AME - 62050	4 - 1/8" Rollock Install Tool



AME - 62550



WHEEL WEIGHT TOOLS

Wheel Weight Tools

Code	Description
50K	Wheel Weight Tool
AME - 51480	Wheel Weight Tool
KD - 33580	KD Wheel Weight Tool
KD - 33584	KD Weight Tool - Replacement Cover
AME - 51290	AME Premium Wheel Weight Tool
TI33	Premium Wheel Weight Tool Replacement Nylon Cap
TI31	TI33 - 4pk
75K	Wheel Weight Tool
50KE	Wheel Weight Tool
75P	Replacement Head for 75k (5/pk)
75H	Replacement Hook for 75k (5/pk)
95K	Wheel Weight Tool
TI38	Nylon Double Head Wheel Weight Tool
25K	Wheel Weight Tool
TI36	Premium Wheel Weight Tool
PT7	Truck Weight Tool
TI34	Heavy Duty Truck Wheel Weight Tool
TR10	Wheel Weight Tool
71K	Wheel Weight Tool
71P	Replacement Head for 71k (5/pk)
85K	Wheel Weight Tool
900008006	Wheel Weight Plier
2 - RPT	Alloy Rim Protection Tool
6410500	Clip Tool for Two - Piece Weights
2 - RCT	Adhesive Wheel Weight Remover
AME - 51460	Heavy Duty Adhesive Wheel Weight Remover
486 - 71511	Heavy Duty Adhesive Wheel Weight Remover
31810	Leather Wheel Protector
UWT1200HP	Wheel Hammer With Remover And Heel
TI156	Large Bulge Acorn Lug Nut
TI956	Wheel Weight Hammer With Heel Plate
TI952	TI956 Replacement #5 Hook
TI973	TI956 Replacement #7 Hook
TI950	TI956 Replacement Cap
TI951	TI956 Replacement Heel Plate
TI963	TI956 Replacement #6 Hook



25K



TI952



50K



TI133

HAWEKA DUOMATIC

Today's Passenger Vehicles Require Precision Mounting Through The Centre Bore Of The Wheel. Even Small Amounts Of Static And Dynamic Unbalance Can Be Felt Due To Sophisticated Suspension Systems On Modern Vehicles.

Code	Description		
105818000	Duomatic System Complete		
164280500	Duo Expert System	Range 54 - 75	Shaft 28
164360500	Duo Expert System	Range 54 - 75	Shaft 36
164380500	Duo Expert System	Range 54 - 75	Shaft 38
165400001	Duo Series 3	Range 54 - 62 mm	Shaft 40
165400002	Duo Series 3	Range 62 - 70 mm	Shaft 40
165400003	Duo Series 3	Range 70 - 78 mm	Shaft 40
164280507	Duo Large	Range 74 - 85 mm	Shaft 28
165400006	Duo Series 3	Range 78 - 86 mm	Shaft 40
165400007	Duoexpert Series 3	54 - 86 mm 4 - Piece	



164280500



HAWEKA CONES

Wheel Balancer Accessories Are Critical To Accurate Balancing. Cones Get Worn Down By Friction Over Time. They Must Be Replaced Regularly. Wear And Tear On Cones Could Be The Problem For Not Getting Repeatability On Your Balancer. Haweka Accessories Can Make An Older Balancer Work Better Than It Did When It Was New.

Code	Description	Range	Size
150280008	Cone	42 - 64.5	Shaft 28
150360008	Cone	42 - 64.5	Shaft 36
150380008	Cone	42 - 64.5	Shaft 38
150400008	Cone	42 - 64.5	Shaft 40
150280009	Cone	54 - 79.5	Shaft 28
150360009	Cone	54 - 79.5	Shaft 36
150380009	Cone	54 - 79.5	Shaft 38
150400009	Cone	54 - 79.5	Shaft 40
150280010	Cone	75 - 100	Shaft 28
150360010	Cone	75 - 100	Shaft 36
150380010	Cone	75 - 100	Shaft 38
150400010	Cone	75 - 100	Shaft 40
150400011	Cone	44 - 80	Shaft 40
150280012	Cone	75 - 111.5	Shaft 28
150360012	Cone	75 - 111.5	Shaft 36
150380012	Cone	75 - 111.5	Shaft 38
150400012	Cone	75 - 111.5	Shaft 40
150280049	Cone	89 - 132	Shaft 28
150360049	Cone	89 - 132	Shaft 36
150380049	Cone	89 - 132	Shaft 38
150400049	Cone	89 - 132	Shaft 40
150360085	3 Cone Set	34 - 111.5	Shaft 36
150380085	3 Cone Set	34 - 111.5	Shaft 38
150400085	3 Cone Set	34 - 111.5	Shaft 40
150280085	3 Cone Set	34 - 111.5	Shaft 28
150360021	3 Cone Set	42 - 100	Shaft 36
150380021	3 Cone Set	42 - 100	Shaft 38
150400021	3 Cone Set	42 - 100	Shaft 40
150280043	Cone	122 - 174	Shaft 28
150280091	Cone/Spacer	122 - 174	Shaft 28
150360091	Cone/Spacer	122 - 174	Shaft 36
150380091	Cone/Spacer	122 - 174	Shaft 38
150400043	Cone	122 - 174	Shaft 40
150400091	Cone/Spacer	122 - 174	Shaft 40
150280025	Truck Center Cone	277.4 - 283	Shaft 28
150360025	Truck Center Cone	277.4 - 283	Shaft 36
150380025	Truck Centering Cone	277.4 - 283	Shaft 38
150400024	Cone - Truck Type	198 - 225	Shaft 40
190400042	Poly Spacer Disc For 150400024		
150400025	Cone - Truck Type	277.4 - 283	Shaft 40
150508025	Cone - Bus Type For Shaft		Shaft 50



150280008



150400008



190280018



190400010



190400018

HAWEKA COLLETS

160280063	Clad Wheel Precision Collet - Jeep
160400063	Clad Wheel Precision Collet - Jeep
150280094	Dual Fit Collet - Ford 87 mm Hub



HAWEKA COLLETS

Code	Description
160400064	Clad Wheel Precision Collet - Dg/Chr
160280060	Cladwheel Precision Collet - F150/KIA
160400060	Cladwheel Precision Collet - F150/KIA
160280062	Clad Wheel Precision Collet - Toyota/Lexus
160400062	Clad Wheel Precision Collet - Toyota/Lexus
150400110	Clad Wheel Low Taper Collets 9 - Piece
150360043	Cone 4.80 - 6.85 Shaft 36



700008004

HAWEKA TRUCK ADPATERS

Code	Description
702280172	Truck Adaptor Kit Shaft 28
702360172	Truck Adaptor Kit Shaft 36
702380172	Truck Adaptor Kit Shaft 38
702400172	Truck Adaptor Kit Shaft 40
702400188	Truck Adaptor Kit - BEIS/SIC/FAC
702460508	Truck Adaptor Kit - Corghi
702508188	Truck Adaptor Kit - Coats/Ammco
725400001	Trilex/Dayton Adaptor 20/22.5
725400002	Trilex/Dayton Adaptor 20/24
00400007	Truck 3 - Arm Clamping Star
700400005	Truck 4 - Arm Clamping Star
700400004	Truck 5 - Arm Clamping Star
700E905012	Basic Truck Adaptor II C/F/S
700E958012	Basic Truck Adaptor II B/H
700E818012	Basic Truck Adaptor II B/S/F
150280024	Centering Cone Truck Shaft 28
150360024	Centering Cone Truck Shaft 36
150380024	Centering Cone Truck Shaft 38
70BE958007	40 mm Truck Centre Cone Disc 220.8 mm
70BE958008	40 mm Truck Centre Cone Disc 219.9 mm



700008004

HAWEKA QUICK NUTS

Available For Any Balancer Shaft/Thread Combination!

Code	Description	Shaft	Pitch
143283003	Progrip Quick Nut Shaft	28	3
143303003	Progrip Quick Nut Shaft	30	3
143363003	Progrip Quick Nut Shaft	36	3
143383003	Progrip Quick Nut Shaft	38	3
143403003	Progrip Quick Nut Shaft	40	3
143285003	Progrip Quick Nut Shaft	28	3.5
143404003	Progrip Quick Nut Shaft	40	4
124288000	Progrip Nut With Clamp Hood	28	8
143283006	Progrip Quick Nut With Handle Shaft	28	3
143363006	Progrip Quick Nut With Handle Shaft	36	3
143383006	Progrip Quick Nut With Handle Shaft	38	3



143283003



HAWEKA QUICK NUTS

Available For Any Balancer Shaft/Thread Combination!

Code	Description	Shaft	Pitch
143285006	Progrip Quick Nut With Handle Shaft	28	3.5
143404006	Progrip Quick Nut With Handle Shaft	40	4
143405006	Progrip Quick Nut With Handle Shaft	40	3.5
143408003	Progrip Quick Nut With Handle Shaft	40	8.46
140285003	Progrip Metal Version	28.5	3.5
124408006	Progrip Nut - Metal With Hood	40	8
124408005	Progrip Metal With C Heavy Duty	40	8.46
140403033	Progrip Nut Metal Version	40	3
140404033	Progrip Nut Metal Version	40	4
140408033	Progrip Nut Metal Version	40	8.46



143285006

HAWEKA ACCESSORIES

Code	Description	Code	Description
190E008049	Distance Ring With Pins And Spacer	190280001	Steel Spacer 28 mm
190E400045	Distance Sleeve	190360001	Steel Spacer 36 mm
190E008047	Distance Ring	190380001	Steel Spacer 38 mm
190008002	Clamping Hood All Handle Wing Nuts	190400001	Steel Spacer 40 mm
190008027	Pressure Ring All Handle Wing Nuts	700008003	Centering Bolt And Nut - Truck
190008005	Clamping Hood - Rubber Pad	700008004	Centering Bolt / Nut - Truck - Dyna
190008021	Large Clamp Hood All Handle Wing Nuts	700008005	Centering Bolt / Nut - Truck - LFA
271804003	Plug-In Stud Short Taper	700008006	Centering Bolt / Nut - Truck - Alloy
271804014	Plug-In Stud 80 Long Taper	700E008009	Knurled Nut For Truck Adaptor
271994208	Plug-In Stud Spring 100 mm	700E008013	Centre Bolight - Truck - 3 - Arm Star
271994008	Plug-In Stud Spring 100 mm		
271992008	Plug-In Stud Spring 100 mm		



271804014



271994208

HAWEKA SHAFTS

Haweke Uses A Coded System Making It Easy To Locate Each Bolt Pattern On The Flange Plate. Four Different Flange Plates Available In Order To Meet All Your Needs.

Code	Description
170589001	Cemb 40 X 4 mm Shaft
170937002	Enlarge Shaft Threaded 40 X 3 mm
170958001	Enlarge Shaft Threaded 40 X 3 mm
170958002	Enlarge Shaft Threaded 40 X 4 mm
170958006	Enlarge Shaft Threaded 40 X 3 mm
170958014	Shaft 40 X 4 mm - Accuturn Balancer
170988001	Threaded Shaft 40 X 3 X 220 mm
170617002	Hunter Threaded Shaft
100E999070	Hunter Mid Centre Device 40 X 8 mm
100E818047	BE/SI/F Mid Centre Device 40 X 4 mm
104988038	Mid Centering Device Threaded 40 X 3 mm
280400077	Centre Kit Dodge/Charger With Clad Wheels
251613409	Centre Kit Dodge/Charger - Flange Plate



170589001



HAWEKA FLANGE PLATE WORLDKITS

Code	Description
200219285	Worldkit US 4 Flange Plates Shaft 28 mm No Wall Board
200209405	Worldkit US 4 Flange Plates Shaft 40 mm With Wall Board
200009285	Worldkit 4 Flange Plates Shaft 28 mm Worldkit
200009405	Worldkit 4 Flange Plates Shaft 40 mm Worldkit
205009405	5 Flange Plates Cemb Pneum 40 mm



HAWEKA USA WORLDKITS

Haweke's Quickplate System Replaces Traditional "Finger Or Flange Plates" With Planetary Gears Which Rotate The Built - In Studs To Centre On The Wheel Perfectly. No More Searching Out - Of - Date Charts For Correct Stud Spacing. The Quickplate Is Made For All 4, 5 And 6 Lug Wheels. With A Simple Twist, The Quickplate System Matches The Wheel Lug - Hole Pattern Of Any Passenger Car, SUV Or Light Truck. With The Haweka Pro - Loc System™, You Can Be Sure That The Bolt Pattern Will Be Locked * This Makes Set Up Fast, Easy And Accurate.

Code	Description	Size
200456285	Quick Plate Set 4/5/6 Hole Shaft	28 mm
200456365	Quick Plate Set 4/5/6 Hole Shaft	36 mm
200456385	Quick Plate Set 4/5/6 Hole Shaft	38 mm
200456405	Quick Plate Set 4/5/6 Hole Shaft	40 mm
205456365	Quick Plate Set 4/5/6 Cemb Shaft	36 mm
205456405	Quick Plate Set 4/5/6 Cemb Shaft	40 mm
203456405	Quick Plate Set 4/5/6 Hofmann Shaft	40 mm



200456285

HAWEKA HEAVY DUTY CENTERING KITS

Heavy Duty Centering Kits

Code	Description	Size
280280044	Ford/GM Multi Kit 16 Shaft	28 mm
280400036	Ford/GM Adapter Kit 19.5 Shaft	40 mm
280400048	Ford Adapter Kit 19/16 Shaft	40 mm
280400049	GM Truck Adapter Kit 19.5/16" Shaft	40 mm
280400059	Special Heavy Duty Centre Kit Ford	40 mm
700E400011	4 - Arm Clamping Adaptor	40 mm
280400060	Special Heavy Duty Centre Kit Chev	40 mm
280400061	Special Heavy Duty Centre Kit Sprinter	40 mm
280400064PN	Flange Plate For Sprinter	40 mm
280400501	Ford F - 450/550 Adapter Kit	40 mm
160400039	Special Dodge Hub Pilot	40 mm
260E111400	Flange Plate Adapter	40 mm
250E131400	Flange Plate Adapter	40 mm
190400061	H. Pilot Sleeve 5.25"	40 mm



280400061



MAGNUM BALANCING COMPOUNDS

Magnum Tire Balancing Compound For Use In Light And Medium Truck Tires. It Features Multiple Density And Moisture Resistance. Dry Material. Put Directly Inside Tire. Ensures Smooth Balance. Self - Adjusts To Any Balancing Changes. Helps Balance Complete Wheel, Assembly As Well As Wheel Bearings And Brake Drums

Code	Description	Size
LTP - 60	Magnum Light Balance Compound	2 oz
LTP - 100	Magnum Light Balance Compound	3 oz
LTP - 150	Magnum Light Balance Compound	4.5 oz
LTP - 200	Magnum Light Balance Compound	6.5 oz
MTP - 250	Magnum Medium Truck Balance Compound	8.5 oz
MTP - 300	Magnum Medium Truck Balance Compound	10.5 oz
MTP - 400	Magnum Medium Truck Balance Compound	13 oz
MTP - 500	Magnum Medium Truck Balance Compound	16 oz
DPP - 600	Magnum Duplex Truck Balance Compound	21 oz
DPP - 700	Magnum Duplex Truck Balance Compound	23.5 oz
DPP - 900	Magnum Duplex Truck Balance Compound	29 oz



LTP - 60

COUNTERACT BALANCING COMPOUNDS

Counteract Balance Beads

Code	Description	Size
CAB01	Counteract Balance Beads	1 oz Bag
CAB02	Counteract Balance Beads	2 oz Bag
CAB03	Counteract Balance Beads	3 oz Bag
CAB04	Counteract Balance Beads	4 oz Bag
CAB05	Counteract Balance Beads	5 oz Bag
CAB06	Counteract Balance Beads	6 oz Bag
CAB08	Counteract Balance Beads	8 oz Bag
CAB10	Counteract Balance Beads	10 oz Bag
CAB12	Counteract Balance Beads	12 oz Bag
CAB14	Counteract Balance Beads	14 oz Bag
CAB16	Counteract Balance Beads	16 oz Bag
CAB - AIB	Counteract Airless Injection Bottle	
CAB - MK1/2	Counteract Motorcycle Kit With 1	1 oz - 2 oz Bags
CAB - MK2/2	Counteract Motorcycle Kit With 2	2 oz Bags



CAB - AIB



CAB03



Tire Changing Tools and Accessories





BEAD BREAKER HAMMERS AND HANDLES

Wood-Handled Bead Breaking Wedge. Used On Passenger, Truck, Bus, Farm, Tractor And Aircraft Tires. Breaking Bead Quickly And Easily. Handle Serves As Lever To Push Bead Away From Rim. Handle Length 17" (43.2Cm). Head Weight 4 - 3/4" Lbs. (2.2 kg)

Code Description

T11D Bead Breaking Hammer Wood 17"



T11D

Wood-Handled Bead Breaking Wedge. Used On Passenger, Truck, Bus, Farm, Tractor And Aircraft Tires. Breaking Bead Quickly And Easily. Handle Serves As Lever To Push Bead Away From Rim. Handle Length 30" (76.2Cm). Head Weight 8 - 1/2" Lbs. (3.9 kg)

Code Description

T11E Bead Breaking Hammer Wood 30"



T11E

Wood-Handled Heavy Duty Tire Hammer. For Mounting And Demounting Tires. Non - Marring Rubber End Can Be Used For Driving On Both Tires And Rims. Handle Length 16 - 1/2" (41.9Cm). Head Weight 5 - 1/2" Lbs. (2.5 kg)

Code Description

T35 Heavy Duty Tire Hammer



T35

Fiberglass-Handled Bead Breaking Wedge. Used On Passenger, Truck, Bus, Farm, Tractor And Aircraft Tires. Breaking Bead Quickly And Easily. Handle Serves As Lever To Push Bead Away From Rim.

Code Description

TG11D Bead Breaking Hammer Bag 18" 4 - 3/4" Lbs

TG11E Bead Breaking Hammer Bag 32" 8 - 1/2" Lbs



TG11D

Polymer-Handled Bead Breaking Hammer With New Design Hump On Breaking Hammer Head To Avoid Denting The Rims.

Code Description

T11K Bead Breaking Hammer Polymer 32"



T11K

Fiberglass-Handled Heavy Duty Tire Hammer. For Mounting And Demounting Tires. Non - Marring Rubber End Can Be Used For Driving On Both Tires And Rims.

Code Description

TG35 Heavy Duty Tire Hammer Fiberglass 18" 4 - 3/4" Lbs

TG36 Heavy Duty Tire Hammer Fiberglass 18" 5 - 3/4" Lbs



TG35

Professional Dead Blow Hammer.

Code Description

TG337 Professional Dead Blow Hammer (Steel Rubber Heads)



TG337

Replacement Wooden Hickory Handle For T11B - 15"

Code Description

T11BH Handle Hickory 15" Length



T11BH



BEAD BREAKER HAMMERS AND HANDLES

Replacement Wooden Hickory Handle For T35 - 17"

Code	Description
T11CH	Hickory Handle 17" Length



T11CH

Wood-Handled Bead Breaking Wedge. Used On Passenger, Truck, Bus, Farm, Tractor And Aircraft Tires. Breaking Bead Quickly And Easily. Handle Serves As Lever To Push Bead Away From Rim. Handle Length 30". Head Weight 8 - 1/2" Lbs.

Code	Description
T11DH	Replacement Wooden Hickory Handle For T11D - 17" (43.2 Cm.)



T11DH

Replacement Wooden Hickory Handle For B3033001GRIP - 30"

Code	Description
B3033001GRIP	Hickory Handle 30"

Replacement Wooden Hickory Handle For T11E - 30"

Code	Description
T11EH	Hickory Handle 30" Length



T11EH - GRIP

T11E Grip Replacement Handle 30" This Is The Ken - Tool Made In The USA . It's Their Version Of The B3033001GRIP Style Replacement Hickory Handle For The Ken - Tool T11E Tire Hammer.

Code	Description
T11EH - GRIP	T11EH Replacement Handle 30"



TG11CH

Replacement Fiberglass Handle For TG35. 18"

Code	Description
TG11CH	18" Fiberglass Handle



TG11DH

Replacement Fiberglass Handle For Tg11d - 18" (45.7 Cm.)

Code	Description
TG11DH	18" Fiberglass Handle With Nu - Lok Adapter



TG11EH

Replacement Fiberglass Handle For Ken - Tool Tg11e Bead Breaking Hammer. This Unit Is 32" Long And Has The Rubber Nu - Lok End That Will Fit Tightly Into The Duck Bill Head.

Code	Description
TG11EH	32" Fiberglass Handle With Nu - Lok Adapter

Replacement Polymer Handle For The Ken - Tool T11K Bead Breaking Hammer. This Unit Is 32" Long And Will Not Fit With The Old Style T11E Head.

Code	Description
T11KH	Polymer Handle 32" Length



T11KH



BEAD BREAKER HAMMERS AND HANDLES

Replacement Rubber Head For T11R, TG11R, T31, TG31, T33R, TG33R

Code	Description
T11RH	Replacement Rubber Head



T11RH

Replacement Rubber Head For T34, TG34, T35, TG35, T36, TG36.

Code	Description
T34RH	Replacement Rubber Head



T34RH

TIRE BARS, IRONS AND SPOONS

Truck Lock Ring Tool To Remove Or Replace Lock Rings. Specially Designed For Firestone RH And TI Rims. Stock 11/16"

Code	Description
T23	Truck Lock Ring Remover 24"
T23A	Truck Lock Ring Remover 30"



T23

Combination Rim/Lock Ring Tool To Remove Or Replace Lock Rings. Flat Tapered End Ideal For All Round Ring And Rim Work. Length 23 - 1/2" Stock 11/16"

Code	Description
T23B	5 Degree Lock Ring Removal Tool 23 1/2"



T23B

5 Degree Rim Lock Tool To Remove Or Replace Lock Rings. For Servicing 5° Wide Base Rims. Length 18". Stock 5/8"

Code	Description
T25	5 Degree Lock Ring Removal Tool 18"



T25

Special Lock Ring Tool To Remove Or Replace Lock Rings. Long Tapered Curved End For R - 1 Continuous Side Rings; Short Curved End For Goodyear Rims. Length 18" Stock 5/8"

Code	Description
T27	Special Lock Ring Tool 18"



T27

Lock Ring Tool To Remove Or Replace Lock Rings. Removes Continuous Side Rings On Two - Piece Truck Rims. Length 18". Stock 5/8"

Code	Description
T27A	Lock Ring Tool 18"



T27A

Heavy Duty Lock Ring Tool To Remove Or Replace Lock Rings. Use For Multi - Piece Wheels, Especially Hub Type. Length 37" Stock 3/4"

Code	Description
T48A	Lock Ring Tool 37" Length



T48A

Mount/Demount Tire Tool. Tools Are Used In Pairs To Mount Or Demount Small Passenger, Industrial, ATV And Motorcycle Tires. Length 16 - 1/2". Stock 5/8"

Code	Description
T6A	Tire Iron Tubeless 16 1/2"



T6A



TIRE BARS, IRONS AND SPOONS

This Short Ken - Tool Bar 9" Is Great For Use When Mounting And Dismounting Small Wheels. (Ie: Golf Carts, Etc.)

Code Description

T9A Short Ken - Tool Bar - 9"



T9A

This Short Ken - Tool Bar 16" Is Great For Use When Mounting And Dismounting Small Wheels. (Ie: Golf Carts, Etc.)

Code Description

T16A Short Ken - Tool Bar - 16"



T16A

Motorcycle Tire Demount Bar. 15"

Code Description

T43A Motorcycle Tire Demount Bar. 15"



T43A

Ken - Tool Align And Pry Bar - 24"

Code Description

7027 Ken - Tool Align And Pry Bar - 24"



7027

2 - Piece Small Ken - Tool Tire Iron Set. Includes 32115 (T5) And 32118 (T8)

Code Description

32114 2 - Piece Small Kentool Tire Iron Set



32114

Ken - tool T5 - 16" Small Tire Iron. Rounded Ends Will Not Pinch Tube. Ideal For Motorcycle, ATV, Lawn Tractor, Golf Cart And Other Small Tires.

Code Description

32115 Ken - Tool T5 - 16" Small Tire Iron



32115

Ken - Tool T8 - 16" Small Tire Iron. Rounded Ends Will Not Pinch Tube. Ideal For Motorcycle, ATV, Lawn Tractor, Golf Cart And Other Small Tires.

Code Description

32118 Ken - Tool T8 - 16" Small Tire Iron



32118

Wood-Handled Rubber Mallet. Rubber Head Prevents Marring Surfaces. Length 17" (43.2Cm)

Code Description

T32 Tire Hammer Wood 17" Length



T32

Straight Tire Spoon For Fast And Efficient Tire Changing For Passenger Car, Motorcycle, ATV And Light Truck Tires. Length 18". Stock 11/16"

Code Description

T1X Tire Iron Straight Spoon 18"



T1X



TIRE BARS, IRONS AND SPOONS

Curved Tire Spoon For Fast And Efficient Tire Changing For Passenger Car, Motorcycle, ATV And Light Truck Tires. Stock 11/16"

Code	Description
T2X	Tire Iron Curved 18"
T21R	Tire Iron Drop Centre 18"
T21F	Drop Centre Spoon - 24"



T2X

Drop Centre Tire Spoon

Code	Description
T21HD	Drop Centre Tire Spoon 30"



T21HD

Straight Tire Spoon For Fast And Efficient Tire Changing For Passenger Car, Motorcycle, ATV And Light Truck Tires. Length 24". Stock 11/16"

Code	Description
T19	Tire Iron Straight Spoon 24"



T19

Straight Tire Spoon For Fast And Efficient Tire Changing. Provides Enough Strength And Leverage To Work On Large Truck, Bus, OTR, Tractor And Aircraft Tires. Length 30". Stock 11/16"

Code	Description
T19A	Tire Iron Straight Spoon 30"



T19A

Curved Tire Spoon For Fast And Efficient Tire Changing For Passenger Car, Motorcycle, ATV And Light Truck Tires. Length 24". Stock 11/16"

Code	Description
T20	Tire Iron Curved 24"



T20A

Curved Tire Spoon For Fast And Efficient Tire Changing. Provides Enough Strength And Leverage To Work On Large Truck, Bus, OTR, Tractor And Aircraft Tires. Length 30". Stock 11/16"

Code	Description
T20A	Tire Iron Curved Spoon 30"



T20A

Straight Tire Spoon For Fast And Efficient Tire Changing. Provides Enough Strength And Leverage To Work On Large Truck, Bus, OTR, Tractor And Aircraft Tires. Length 30". Stock 7/8"

Code	Description
T38	Tire Iron Straight Spoon 30"



T38

Curved Tire Spoon For Fast And Efficient Tire Changing. Provides Enough Strength And Leverage To Work On Large Truck, Bus, OTR, Tractor And Aircraft Tires. Length 30" (76.2Cm). Stock 7/8" (22.0 mm)

Code	Description
T39	Tire Iron Curved Spoon 30"



T39

Truck Wrench Handle. Extra Long For Increased Leverage. Heat Treated For Extra Strength. Length 22". Stock 3/4" Hex.

Code	Description
TR5	Truck Wrench Handle 22"



TR5



TIRE BARS, MOUNT/DEMOUNT

Standard Tubeless Tire Mount/ Demount Iron. For Truck, Agricultural And Industrial Tires. Long Life And Superior Performance. Heat Treated For Strength. Length 37". Stock 3/4"

Code	Description
T45A	Tire Iron Tubeless Truck 37"



T45A

Classic Tubeless Tire Mount/ Demount Iron. For Truck, Agricultural And Industrial Tires. Long Life And Superior Performance. Heat Treated For Strength. Length 37". Stock 3/4"

Code	Description
T45AC	Classic Tubeless Tire Iron - 37"



T45AC

New Tubeless Tire Mount/ Demount Iron. For Truck, Agricultural And Industrial Tires. Long Life And Superior Performance. Improved Blade And Knob Design. Length 38". Stock 3/4" New Style.

Code	Description
T45A - 2000K	2000K Tubeless Tire Iron 38"



T45A - 2000K

Heavy Duty Tubeless Tire Mount/ Demount Iron. For Truck, Agricultural And Industrial Tires. Long Life And Superior Performance. Heat Treated For Strength. Length 41". Stock 7/8"

Code	Description
T45HD	Tire Iron HD Truck Tubeless 41"



T45HD

Straight Tubeless Mount/ Demount Iron. Use On Standard And Large Truck Tires, Including Industrial, Farm, Buses And Tractors. Length 36" (91.4Cm). Stock - 3/4" (19 mm)

Code	Description
T46A	Tire Iron Tubeless 36"



T46A

Straight Mount/ Demount Tool. Use "C" Offset Bar With "B" Straight Extension For Easier Use On Large Wide - Base Truck Tires. Length 36". Stock 3/4"

Code	Description
T46B	Tire Iron Tubeless 36"



T46B

Offset Mount/ Demount Tool. Use "C" Offset Bar With "B" Straight Extension For Easier Use On Large Wide - Base Truck Tires. Length 22". Stock 3/4"

Code	Description
T46C	Tire Iron Tubeless 22"



T46C

Heavy Duty Straight Tubeless Mount/ Demount Iron. Use On Standard And Large Truck Tires, Including Industrial, Farm, Buses And Tractors. Length 52" Stock 1"

Code	Description
T47A	Tire Iron Tubeless 52"



T47A

Ironman Tire Lifter Bar - 58" Has Specially Designed Knob End For Hub Side Up And Spoon End For Hub Side Down. Reduces Back Strain And Injury.

Code	Description
T950	Ironman Tire Lifter Bar 58"



T950



TIRE BARS, MOUNT/DEMOUNT

19.5 Mount/Demount Truck Tire Iron 38" Specially Designed To Clear The Hub And Tackle Those Stiff, High Ply, Thick Beads. To Work On Hub Side Of Wheel.

Code	Description
33199	19.5 Mount/Demount Truck Tire Iron 38"

Bead Holder For 19.5 Aluminum Wheels. 7 - 1/2" Long. Can Also Be Found In The 33195 Tire Mounting And Demounting Set.

Code	Description
33196	Bead Holder For 19.5 Aluminum Wheels

Heavy Duty Straight Mount/Demount Tool. Use "C" Offset Bar With "B" Straight Extension For Easier Use On Large Wide - Base Truck Tires. Length 49 - 1/2" Stock 1"

Code	Description
T47B	Tire Iron Tubeless 49 1/2"

Heavy Duty Offset Mount/Demount Tool. Use "C" Offset Bar With "B" Straight Extension For Easier Use On Large Wide - Base Truck Tires. Length 27" Stock 1"

Code	Description
T47C	Tire Iron Tubeless 27"

Forklift Lock Ring Tire Iron Set. Includes The 32130 And 32131

Code	Description
32129	Forklift Lock Ring Tire Iron Set

Forklift Lock Ring Mount/Demount Iron - 15 - 3/4"

Code	Description
32130	Forklift Lock Ring Mount/Demount Iron 15 3/4"

Forklift Lock Ring Demount Prep Tool - 15 - 1/2" Has Separator End And Pry - Out End.

Code	Description
32131	Forklift Lock Ring Demount Prep Tool

Ken - Tool Serpent Demount Tool. Demounts Both Beads Of Most Truck Tires Without The Need For Lifting The Tire/Wheel Assembly Off The Ground. Heat - Treated Alloy Steel That Is Both Durable And Strong. Length 39". 3/4" Thick Steel.

Code	Description
T2001	Ken - Tool Serpent Demount Tool

Ken - Tool Serpent Mount Tool. Wing Shape Is Designed To Stop Against The Rim And Then Remove Itself Effortlessly From Between The Rim And Bead. Heat - Treated Alloy Steel That Is Both Durable And Strong. Length 38". 11/16" Thick Steel.

Code	Description
T2002	Ken - Tool Serpent Mount Tool

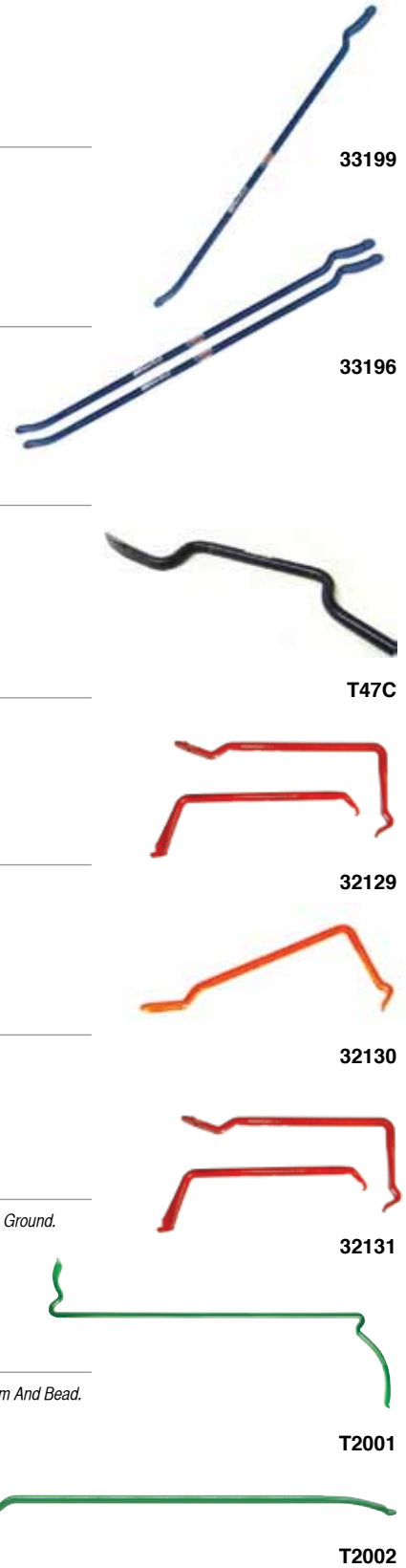



TIRE BARS, MOUNT/DEMOUNT

T2005 Super Serpent Mount Tool. Delivers Twice The Leverage Of Any Straight - Type Tire Mounting Tool. Length - 37". Stock - 3/4"

Code	Description
35447	T2005 Super Serpent Mount Tool 37" - Length

T2006 Super Serpent Demount Tool. Delivers Twice The Leverage Of Any Straight - Type Tire Mounting Tool. Length - 37". Stock - 3/4"

Code	Description
35448	T2006 Super Serpent Demount Tool 37" - Length

Ken - Tool Super Serpent 5 - Piece Tire Changing Set. This Set Includes 1 - T2005 Mount Tool, 1 - T2006 Demount Tool, 2 - 31710 Bead Holders And 1 - 31810 Wheel Protector.

Code	Description
35446	Ken - Tool Super Serpent 5 - Piece Set

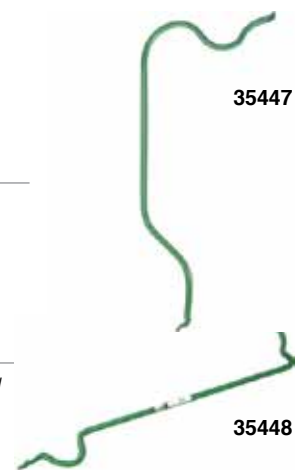

BEAD SEATERS

One Piece Rubber Tube For Mounting Tubeless Tires. As Tire Is Inflated, Forms A Seal Between Rim And Tire Bead.

Code	Description
BS - 1314	13" And 14" Bead Seater
BS - 1415	14" And 15" Bead Seater
BS - 16	16" Bead Seater - Donut
BS - 17	17" Bead Seater - Donut
BS - 18	18" Bead Seater - Donut
BS - 20	20" Bead Seater - Donut
BS - 22	22" Bead Seater - Donut
1994	16.5" - 17.5" Bead Seater - Donut
1996	19.5" Radial Truck Tire Bead Seater
1997	22.5" And 24.5" Radial Truck Tire Bead Str



2 Gallon Bead Seater With ASME Certified Tank For Commerical Use On Smaller Tire/Wheel Combinations - ATV'S, Golf Carts, Wheelbarrow, Cement Mixers, Etc.

Code	Description
CH2	2 Gallon Cheetah Bead Blaster



6 Gallon Bead Seater With ASME Certified Tank For Commerical Use On Large Truck Tires, Passenger And ATV Tires.

Code	Description
CH5	5 Gallon Cheetah Bead Blaster

5 Gallon Bead Seater With ASME Certified Tank For Commerical Use On Large Truck Tires, Passenger And ATV Tires. Aluminum Version

Code	Description
CH5AL	5 Gallon Aluminum Tank For Passenger Truck





BEAD SEATERS

Gaither Standard Bead Booster 5 Gallon. This Completely Portable Unit Features A Safety Relief Valve To Prevent Overfilling, Earplugs And Eye Protection. ASME And CE Certified. Will Seat Beads On Light Truck, RV, Large Truck And Small Agricultural Tires.

Code	Description
GT - GB5Z	Gaither Standard Bead Booster 5 Gallon



GT - GB5Z

Gaither Automatic Bead Booster 5 Gallon. This Completely Portable Unit Features A Press Trigger, Safety Relief Valve, Earplugs And Eye Protection. ASME And CE Certified. Will Seat Beads On light Truck, RV, Large Truck And Small Agricultural Tires.

Code	Description
GT - GB5ZA	Gaither Auto Bead Booster 5 Gallon



GT - GB5ZA

Gaither Bead Bazooka Bead Seating System. This Unit Only Weighs 14 Lbs. Powerful Air Release. Double Barrel Fire From 6 Litre And 9 Litre Tank. For Use On Passenger, Motorcycle, ATV, Truck And Small Agricultural Tires. Very Light To Work With.

Code	Description
GT - BB06L	Gaither Bead Bazooka - 6L Tank
GT - BB09L	Gaither Bead Bazooka - 9L Tank



GT - BB06L

6 Gallon Bead Seater With ASME Certified Tank For Commerical Use On Large Truck Tires, Passenger And ATV Tires. This Unit Features A Wide Air Nozzle.

Code	Description
BS07	5 Gallon Wide Nozzle Bead Seater



BS07

10 Gallon Bead Seater With ASME Certified Tank For Commerical Use On Large Truck Tires, Passenger And ATV Tires.

Code	Description
CH10	10 Gallon Tank For Passenger/Truck



CH10

10 Gallon Bead Seater With ASME Certified Tank For Commerical Use On Large Truck Tires, Passenger And ATV Tires. Aluminum Version

Code	Description
CH10AL	10 Gallon Aluminum Tank For Passenger/Truck



CH10AL

13 Gallon Bead Seater With ASME Certified Tank For Commerical Use On Large Truck Tires, Passenger And ATV Tires. This Unit Includes A Mag - I Barrel, Goggles And Is Made Of Lightweight Aluminum.

Code	Description
CH13AL - MTO	13 Gallon Cheetah Aluminum With M - I



CH13AL - MTO

OTR Cheetah Bead Seater System Complete With The 60 Gallon Tank, 1 - 20' Whip Hose, 2 - 8' Sections Of 2 - 1/2" Air Hose, Tractor Wheel Stand And The Adjustable 24" To 54" Air Blast Seating Apparatus.

Code	Description
CH60	OTR Cheetah Bead Seater System Complete
CH60 - LT	OTR Cheetah Bead Seater System Without Tank



CH60 - LT

Gaither

PROFESSIONAL EQUIPMENT



GT3531
SERVICE JACK



Patents Pending

THE ALL NEW
BEAD BAZOOKA

BEAD BAZOOKA® BB6L
BEAD BAZOOKA® XL BB9L



FLOOR JACKS
BOTTLE JACKS
JACK STANDS



SMART
CART



Patents Pending





BEAD SEATERS

Rema Pump Ring Bead Seater

Code	Description
1375	Rema 16.5" Pump Ring Bead Seater
1376	Rema 19.5" Pump Ring Bead Seater
1377	Rema 22.5" Pump Ring Bead Seater
1378	Rema 24.5" Pump Ring Bead Seater
1377 - RI	22.5" Pump Ring Rubber Insert
1378 - RI	24.5" Pump Ring Rubber Insert



1377



BS07 - 3 - 102

BEAD SEATERS, PARTS AND ACCESSORIES

Code	Description
BS07 - 3 - 102	BS07 - Discharge Valve 2" Also Fits The CH10 And CH13. Also Called A Butterfly Valve.
BS07 - 01 - 230BT	BS07 - Handle Only For The BS07 Discharge Valve
BS07 - 01 - 106BS	BS07 - 200 Psi Gauge
MAG - I	Magnum - I Barrel CH5
MAG - II	Magnum - II Barrel CH10 / CH13
BS07 - 6813	BS07 - Flared Barrel
BS07 - 05 - 102	BS07 - Safety Release Valve
CH5 - 02 - 102	CH5 - Discharge Valve With Handle
CH5 - 02 - 103	CH5 - Threaded Barrel
CH5 - 01 - 106	CH5 - 200 Psi Gauge
CH5 - 01 - 107	CH5 - 3/4" - 1/4" Bushing
CH5 - 03 - 104	CH5 - 90 Degree N.P.T.
CH5 - 04 - 103	CH5 - Ball Valve



CH5 - 01 - 106



BS07 - 01 - 230BT



CH5 - 01 - 107



BS07 - 01 - 106BS



CH5 - 04 - 103



CH5 - 02 - 102



CH5 - 03 - 104



CH5 - 02 - 103

BEAD BAZOOKA PARTS AND ACCESSORIES

All Parts Are Interchangeable Between 6L And 9L Bazookas

Code	Description
GT - 12913B	Bead Bazooka - Slotted Barrel
GT - 12914B	Bead Bazooka - Pressure Gauge
GT - 12916B	BB06I Bead Bazooka - Intake Valve
GT - 12917B	BB06I Bead Bazooka - 115 Psi Safety Valve
GT - 12919B	Bead Bazooka - Switch Valve
GT - GB51	Bead Bazooka Stand
GT - GBBH - 01	Bazooka Inflation And Storage Stand



GT - 12913B



GT - GBBH - 01



GT - 12914B



GT - 12917B



GT - 12919B



GT - 12916B



BEAD BREAKERS

Economy Impact Bead Breaker. Loosens Beads With Bead - Breaking Foot And Ram Bar. Never Cuts Bead. Wedge Foot Is Forced Between Bead And Rim Flange. No Other Bead Breaking Tools Needed. Length 46" - . Extended - Length 72". Weight 13 - 1/2" Lbs

Code **Description**
T24B Slide Bar Bead Breaker With O - Spring

Heavy Duty Impact Bead Breaker. Loosens Beads With Bead - Breaking Foot And Ram Bar. Never Cuts Bead. Wedge Foot Is Forced Between Bead And Rim Flange. No Other Bead Breaking Tools Needed. Length 50" - Length Extended 80". Weight 24 Lbs

Code **Description**
T26B Slide Bar Bead Breaker With Spring

Slide Bar Bead Breaker With Spring. Easily Breaking Most Stubborn Beads. Spring Action Reduces Kick - Back. A Wedge Tip Is Forced Between The Tire Bead And Wheel Rim Delivering The Blow Directly To The Hammer Tip.

Code **Description**
AME - 71500 Slide Bar Bead Breaker With Spring

Bead Breaking Tool For Truck, Farm And OTR. One End Is Used To Remove Frozen Or Rusted Beads. The Other End Can Be Used For Mounting.

Code **Description**
T52 Bead Breaker - Lever Bar - 33" - Length

Swan Neck Bead Tool - 30"

Code **Description**
T41 Swan Neck Bead Tool - 30" - Length

Forcing Tool For 5° Rims. One End Is Used To Remove Frozen Or Rusted Beads.

Code **Description**
T42 Bead Breaker Tool - 30" - Length

Gaither Boa Constrictor System. This Unique Product Attaches To Standard Air Lines And Literally Squeezes The Bead Away From The Wheel By Creating A Vacuum Inside Of The Tire. Eliminates The Possibility Of Both Bead & Wheel Damage When Breaking A Tire Down.

Code **Description**
BC - 04 Gaither Boa Constrictor System



T26B



T24B

AME - 71500



T52



T41



T42



BC - 04



BEAD BREAKERS

Combi Tire Bead Breaker. Great For Breaking Beads On All Agricultural And Construction Wheels Up To 25". Tool Clamps Hydraulically To Wheel And Then Breaking Bead With 11 Tons Force. 3 - 3/4" Ram Stroke. Requires 10,000 Psi Air/Hydraulic Pump.

Code	Description
AME - 11010	Combi Tire Bead Breaker



AME - 11010

Titan Farm Tire Bead Breaker. Compact Design Makes Unit An Affordable Option. 4" Stroke Length.

Code	Description
AME - 11015	Titan Farm Tire Bead Breaker

Modified OTR Combi Bead Breaker. Works On All 3 - Piece Wheels That Replace Older 5 - Piece Wheels. Designed To Work On Front Or Back Of Wheel With No Attachments. Clamps On Easily. Operates At 10,000 Psi.

Code	Description
AME - 11020	Modified Combi Bead Breaker



AME - 11015

DiamondBack Aluminum Tire Bead Breaker with Carrying Case

Code	Description
AME - 11076	Maxi Lite Bead Breaker With Carry Case



AME - 11020

OTR 5 - Piece Rim Bead Breaker. Use On 5 - Piece Rims 25" - 51" Without Pry Bar/Bead Loosening Pockets. Replaces Goodyear To 0100 - HA.

Code	Description
AME - 11040	OTR 5 - Piece Rim Bead Breaker

OTR Bead Seat Band Installer. Use Hydraulic Force To Install Bead Bands On Earthmover Tires. 25 Tons Of Force.

Code	Description
AME - 11900	OTR Bead Seat Band Installer



AME - 11076

Dual Agricultural Tractor Tire Bead Breaker. 10 Tons Of Force Breaking The Toughest Beads. Breaking Inside Bead On Outside Dual Farm Tractor Tires. Requires 3" Of Operating Space Between Tires. Closed Distance Is 3".

Code	Description
AME - 11060	Dual Agricultural Tractor Tire



AME - 11060





BEAD BREAKERS

OTR Giant Tire Bead Breaker. Great Tool For Beaking Beads On OTR Tires 25" - 51". Works On 5 - Piece Wheels. 4 - 1/4" Ram Stroke. 13.8 Tons Hydraulic Force. Must Be Used In Conjunction With A 10,000 Psi Air/Hydraulic Pump.

Code	Description
AME - 11000	OTR Giant Tire Bead Breaker



AME - 11000

Titan Earthmover Tire Bead Breaker. Compact Design Makes Unit An Affordable Option. 4" Stroke. Unit Will Work On 5 - Piece Rims With Bead Loosening Pockets. 10 Ton Cylinder.

Code	Description
AME - 11005	Titan Earth Mover Tire Bead Breaker

OTR Giant Tire Bead Breaker. Use On 5-Piece Rims 25" - 29". Has Pry Bar Bead Loosening Pockets. 2 - 1/8" Stroke, 10 Ton Ram Will Break The Toughest Beads. Compact Design.

Code	Description
AME - 11050	OTR Giant Tire Bead Breaker



AME - 11050

OTR Extra Giant Tire Bead Breaker. For Use On 39" - 63" Wheels. Originally Marked As To - 2000 - HA. Large 25 Ton Cylinder. Incredible Force. 6" Stroke. Use With 10,000 Psi Air/Hydraulic Pump 5 Quarts or More. Use With AME - 16270 Kit For 63" Wheels.

Code	Description
AME - 11030	OTR X - Giant Tire Bead Breaker



AME - 11030

OTR 3000 X - Giant Bead Breaker With Universal Jaw Kit. Designed Specifically To Work On Topy And Rimex OE Wheels Found On Terex, Komatsu, Liebherr And Le Tourneau. Unique Jaws To Ensure Perfect Clamp Connection On Particular Rims.

Code	Description
AME - 11044	OTR 3000 X - Giant Bead Breaker With Jaw Kit



AME - 11044

OTR Stinger Bead Breaker 3-Piece

Code	Description
AME - 11090	OTR Stinger Bead Breaker 3-Piece



AME - 11090





BEAD BREAKERS

5 Tons Of Force Breaking Toughest Beads. Breaking Inside Bead On Outside Dual Tractor Tires. Requires 4" - 12" Operating Space Between Tires.

Code	Description
AME - 11065	AME Dual Agricultural 300 Bead Breaker



AME - 11065

Manual Tire Bead Breaker That Is Fast, Easy To Use And Saves You Time. Designed For Use With 1/2" Drive Ratchet Or Impact Wrench.

Code	Description
TC - 610	Manual Tire Bead Breaker



TC - 610

AME Manual Bead Breaker - Little Buddy. For Working On A Tire Without Removing The Wheel. Handles 38" And 42" 14 - Ply Farm Tractor And Backhoe Tires With Drop Centre Rims. Also Great For ATV / Lawn Mower Tires. Use With Air Ratchet Or Manual Wrench.

Code	Description
AME - 71600	AME Manual Bead Breaker



AME - 71600

Lightweight Bead Push Off Tool. Great For Use On Combine, Forestry And Tractor Tires After Breaking The Bead. Pushing Force Of 8000 Large Bores. Features A 5.5" Stroke. The Push - Off Tool Hooks Between The Rim And The Tire Bead. Same As IMT - 150

Code	Description
AME - 11080	AME Bead Push Off Tool



AME - 11080

Pneumatic Bead Breaker. This USA Made Unit From Gaither Can Be Used On Truck, Agricultural And OTR Tires. Works In Conjunction With An Air Regulator. Extremely Fast And Easy To Use Without Risking Bead Damage.

Code	Description
GT - ABB01	Pneumatic Bead Breaker

HYDRAULIC RAMS

Code	Description	Stroke
AME - 13010	Hydraulic Ram - 10 Ton	2 - 1/8" - Stroke
AME - 13020	Hydraulic Ram - 10 Ton	4" Stroke
AME - 13030	Hydraulic Ram - 10 Ton	6 - 1/8" Stroke
AME - 13040	Hydraulic Ram - 10 Ton	8" - Stroke
AME - 13050	Hydraulic Ram - 10 Ton	10 - 1/8" Stroke
AME - 13060	Hydraulic Ram - 30 Ton	2 - 7/16" Stroke
AME - 13090	Hydraulic Ram - 25 Ton	8 - 1/4" Stroke
AME - 13100	Hydraulic Ram - 25 Ton	6 - 1/4" Stroke
AME - 13070	Aluminum - A - Stack Hydraulic Ram Kit	
AME - 13210	Low Height 20 Ton 4"	7.6" - Stroke
AME - 13220	Low Height	9.6" - Stroke



AME - 13070



HYDRAULIC PUMPS AND ACCESSORIES

Code	Description
AME - 15905	2.5 Quart Titan Air Hydraulic Pump With Polyethylen Reservoir, 10,000 PSI
AME - 15000	3.5 Quart AME Air Hydraulic Pump With Polyglass Reservoir, 10,000 PSI
AME - 15920	5 Quart AME Air Hydraulic Pump With Steel Reservoir, 10,000 PSI
AME - 15940	8 Quart Air Hydraulic Pump With Metal Reservoir, 10,000 PSI
AME - 16030	8 Foot Hydraulic Hose With Coupler and Adaptor, 10,000 PSI
AME - 16050	3/8" Male Hose Adaptor, 10,000 PSI
AME - 16060	3/8" Female Hose Coupler, 10,000 PSI



AME - 15905



AME - 15000



AME - 15920



AME - 16030



AME - 16060



AME - 16050



AME - 15940

BEAD BREAKERS PARTS AND ACCESSORIES

AME Bead Breaker Upgrade Kit. Converts Combi Bead Breaker To Work On New 3-Piece Wheels.

Code	Description
AME - 16200	AME Bead Breaker Upgrade Kit



AME - 16200

AME Bead Breaker Upgrade Kit. This Kit Is Meant For Older Style Bead Breakers From IMT, FEC Or Stellar.

Code	Description
AME - 16150	AME Bead Breaker Upgrade Kit



AME - 16150

AME Bead Breaker Upgrade Kit. Converts Original Aluminum Bead Breakers (AME - 11070 Or IMT) To AME - 11075 With Longer Clamping Teeth And Centre Foot.

Code	Description
AME - 17200	AME Bead Breaker Upgrade Kit



AME - 17200



BEAD BREAKERS PARTS AND ACCESSORIES

Bead Breaker Part - Hex Head Screw. Works On The AME - 11000 And AME - 11050

Code	Description
AME - 11000 - 005	Bead Breaker Part - HEX HD Screw



AME - 11000 - 005

Bead Breaker Part - Swivel Foot. Works On AME - 11000 And AME - 11050. This Part Does Not Come With The Retaining Ring And Should Be Purchased Separately.

Code	Description
AME - 11000 - 006	Bead Breaker Part - Swivel Foot



AME - 11000 - 006

OTR Hook Kit For 63" Wheels. This Kit Is Used On Large 63" OTR Wheels With Large Rim Flange. Use With AME - 11030 X - Giant Bead Breaker.

Code	Description
AME - 16270	OTR Hook Ex. Kit For 63" Wheel

BEAD BREAKERS, MISCELLANEOUS PARTS

Bead Breaker Parts, Center Hook For Giant OTR Bead Breaker, Caterpillar Shur - Lok Rim Adapter Kit, For Caterpillar OTR Rims With Modified Shur - Lok System. Allows Bead Breaker To Be Tightened Against A Flat Surface.

Code	Description
AME - 16070	Caterpillar Shur - Lok Rim Adapter Kit
AME - 11000 - 007	Bead Breaker Part - Hook
AME - 11010 - 050	AME - 11010 Part - Replacement Tooth
AME - 11010 - 051	AME - 11010 Part - Clamping Bolt
AME - 11010 - 017	AME - 11010 Part - Spring
AME - 11010 - 052	AME - 11010 Part - Clamping Spacer
AME - 11010 - RK	AME - 11010 Part - Repair Kit
AME - 11010 - 045	AME - 11010 Part - Retainer Ring
AME - 11010 - 022	AME - 11010 Part - Centre Claw
AME - 11010 - 048	AME - 11010 Part - T Handle
AME - 11043	Shur - Lok Bead Band Jaw - 51 - 57"
AME - 11075 - 022	AME - 11075 - Centre Tongue
AME - 11075 - 021	AME - 11075 - Clamping Teeth
AME - 11075 - RK	AME - 11075 - Repair Kit With Seals
AME - 11010 - 045	AME - 11010 Part - Retainer Ring
AME - 11010 - 022	AME - 11010 Part - Centre Claw
AME - 11010 - 048	AME - 11010 Part - T Handle



AME - 11010 - RK



AME - 11000 - 007



AME - 11010 - 052



AME - 11010 - 022

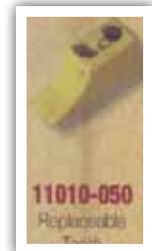

AME - 11010 - 050



AME - 11010 - 051



MOUNT/DEMOUNT TOOLS

Ken - Tool Blue Cobra Truck Tire Demounting Tool. Durable Steel Tool. Approximately. 54" Long. Great For 22.5" And 24.5" Truck Tires. Fast And Easy To Use.

Code **Description**

35440 Blue Cobra Truck Demount Tool



35440

Ken - Tool 35440 Blue Cobra - Wheel Replacement Kit. This Kit Includes 2 Heavy Duty Replacement Wheels And 2 Replacement Wheel Pins.

Code **Description**

35441 35440 Blue Cobra - Wheel Replacement Kit



35441

Nineteen - Five™ Mounting/Demounting 5 - Piece Set

Code **Description**

33195 Mounting/Demounting 5 - Piece Set

Gaither Truck Tire Tool Mount/Demount Changeover System. This Is The Entire Package Including Bar And Accessories.

Code **Description**

GT - 12880 Gaither Mount/Demount Truck Tire Change Tool



GT - 12880

2 - Piece Mount/Demount Tool. Handles All Standard 19.5", 22.5" And 24.5" Tubeless Tires Up To 315/8"0R22.5 Including Those Mounted On Aluminum Wheels.

Code **Description**

TC600 2 - Piece Mount/Demount Tool



TC600

AME Mount/Demount Truck Tire Removal System. This Tool Set Includes The AME - 71051 Demount Tool Plus The AME - 71052 Mount Tool And The AME - 71053 Metal Bead Holder.

Code **Description**

AME - 71050 AME Mount/Demount Truck Tire Removal System



AME - 71050

AME Truck Tire Demount Tool. This Is The Demount Tool Portion Of The AME - 71050 Truck Tire Mount/Demount System.

Code **Description**

AME - 71051 AME Truck Tire Demount Tool



GT - 12100

AME Truck Tire Mount Tool. This Is The Mount Tool Portion Of The AME - 71050 Truck Tire Mount/Demount System.

Code **Description**

AME - 71052 AME Truck Tire Mount Tool

Gaither Demounting Tool

Code **Description**

GT - 12100 Gaither Demounting Tool



GT - J1

Gaither 2 - Piece Mount/Demount Tool System For All 19.5", 22.5" And 24.5" Tubeless Tires Up To A 315/8" 0R22.5. Done Completely On The Ground, No Longer Necessary To Stand The Tire Up. Consists Of 1 - Gt - J1B Bar And 1 - GT - 12902 Clevis.

Code **Description**

GT - J1 Gaither 2 - Piece Mount/Demount Tool

When Using The TNT - 200 System For Super Single Truck Tires, You Will Need The Bead Catch Adapter For Super Single Sizes 315 Through 445.

Code **Description**

TNT - 200 - BCA TNT - 200 System - Bead Catch Adpt



TNT - 200 - BCA



MOUNT/DEMOUNT TOOLS

TNT - 100 Tool Mounts And Demounts Truck Tires With Ease. Two Simple Tools Do All The Work And Do Not Damage The Beads. This Includes Both The TNR - 100 - 1 Demount Tool And The TNR - 200 - M Mount Tool.

Code	Description
TNT - 100	Tire Changing Tool



TNT - 100

TNT - 100 Tool Mounts And Demounts Truck Tires With Ease. Two Simple Tools Do All The Work And Do Not Damage The Beads. This Is The Demounting Tool Only.

Code	Description
TNT - 100 - 1	TNT - 100 - Demounting Tool Only



TNT - 100 - 1

TNT - 100 Tool Mounts And Demounts Truck Tires With Ease. Two Simple Tools Do All The Work And Do Not Damage The Beads. This Is The Mounting Tool Only For Both The TNT - 100 And TNT - 200 Systems.

Code	Description
TNT - 200 - M	TNT System - Mount Tool Only
TNT - 200	Tire Changer Tool - Super Single
TNT - 200 - 1	TNT - 200 - Demounting Tool Only



TNT - 200 - M

CALCIUM PUMPS

Code	Description
AME - 15090	1" Graco Calcium Pump Kit
AME - 15100	1" Yamada Calcium Pump Kit



AME - 15090



AME - 15100

TOOLS DESIGNED BY TIRE PROFESSIONALS FOR TIRE PROFESSIONALS

15920



11076



13154



13010-13050

11000



11010



11044





Air Line Fittings And Accessories





AIR HOSE

Rubber Air Hose. Made Of Heavy Duty 2 - Ply Hose. Resists Most Common Oils And Dirt In Shops. Rated For 300 Lbs. Working Pressure.

Code	Description
2 - 322 - 10	5/16" ID X 10' Rubber Hose 1/4" Male Ends
2 - 322	5/16" ID X 25' Rubber Hose 1/4" Male Ends
2 - 322 - 30	5/16" ID X 30' Rubber Hose 1/4" Male Ends
2 - 322 - 50	5/16" ID X 50' Rubber Hose 3/8" Male Ends
2 - 322 - 35	5/16" ID X 35' Rubber Hose 1/4" Male Ends
2 - 322 - 40	5/16" ID X 40' Rubber Hose 1/4" Male Ends
2 - 323	5/16" ID X 50' Rubber Hose 1/4" Male Ends
2 - 322 - 100	5/16" ID X 100' Rubber Hose 1/4" Male Ends
2 - 324	1/2" ID X 25' Rubber Hose 1/2" Male Ends
2 - 325	1/2" ID X 50' Rubber Hose 1/2" Male Ends
2 - 324 - 75	1/2" ID X 75' Rubber Hose 1/2" Male Ends
2 - 325 - 100	1/2" ID X 100' Rubber Hose 1/2" Male Ends
2 - 325 - 150	1/2" ID X 150' Rubber Hose 1/2" Male Ends
7092 - 38250	3/8" ID X 700' Parker Air Hose



2 - 322 - 10



2 - 324



HR - 38RONLY



HR - 12STOP

AIR HOSE REELS

Hosetract Air Hose Reels Are Ideally Suited For Automotive And Industrial Situations. Each Unit Is Durable And Finished In A Powder Coating For Long - Term Wear. This Unit Includes A 3/8" X 50' Hose.

Code	Description
HR - 3850	Air Hose Reel With 3/8" X 50' Hose
HR - 38RONLY	3/8" Air Hose Reel Only
HR - 1250	Air Hose Reel With 1/2" X 50' Hose
HR - 12RONLY	1/2" Air Hose Reel Only
HR - 38STOP	3/8" Hose Reel Rubber Stopper
HR - 12STOP	1/2" Hose Reel Rubber Stopper

COILED POLY AIR HOSE 1/4"

Poly Coil Hose 1/4"

Code	Description
A770 - 10	Poly Coil Hose 1/4" - 10'
A770 - 25	Poly Coil Hose 1/4" - 25'
A770 - 50	Poly Coil Hose 1/4" - 50'



A770 - 25

COILED POLY AIR HOSE - 3/8"

Poly Coil Hose 3/8" - This Unit Comes Standard With 1/4" Male N.P.T. Ends.

Code	Description
A772 - 15	Poly Coil Hose 3/8" - 15'
A772 - 25	Poly Coil Hose 3/8" - 25'
A772 - 50	Poly Coil Hose 3/8" - 50'



A772 - 25

REMA AIR HOSE

Reinforced Air Hose

Code	Description
891 - THR	50 Ft Reinforced Air Hose - 3/8"
890	25 Ft Reinforced Air Hose - 3/8"
892	500 Ft Reinforced Air Hose - 3/8"
895	50 Ft Reinforced Air Hose - 3/8"
897	80 Ft Air Hose 1/2" Diameter X 1"
896	500 Ft Reinforced Air Hose - 1/2"



891 - THR

**WHIP HOSES**

Whip Hoses Are Designed To Withstand Harsh Job Conditions. Paired With Any Percussive Air Tool, It Prevents Undesirable Straightness From Being Placed On The Air Line Connector And/Or Plug. Also Prevents The Air Line From Flailing Around If Accidentally Cut, Meaning Greater Safety On Job Site.

Code	Description
EX - 922H - 1	1/4" Whip Hose With 1/4" Male Ends length 1'
EX - 922H - 3	1/4" Whip Hose With 1/4" Male Ends length 3'
EX - 922H - 6	1/4" Whip Hose With 1/4" Male Ends length 6'
EX - 922H - 9	1/4" Whip Hose With 1/4" Male Ends length 9'
EX - 922H - 10	1/4" Whip Hose With 1/4" Male Ends length 10'
EX - 922H - 15	1/4" Whip Hose With 1/4" Male Ends length 15'
EX - 922H - 20	1/4" Whip Hose With 1/4" Male Ends length 20'



EX - 922H - 1

HOSE CLAMPS

Reusable Air Hose Repair Coupling. Quickly And Easily Joins Together Two Good Lengths Of Air Hose After Damaged Section Removed.

Code	Description
22 - 433	Reuse Hose Splicer 1/4" ID 5/8" OD
22 - 123	Reuse Hose Fit 1/4" Male N.P.T. x 19/32" OD
22 - 133	Reuse Hose Fit 1/4" Male N.P.T. x 5/8" OD
22 - 163	Reuse Hose Fit 3/8" Male N.P.T. x 11/16" OD
22 - 172	Reuse Hose Fit 3/8" Male N.P.T. x 3/4" OD



22 - 433



22 - 123

NITROGEN INFLATION

Code	Description
110	Branick Nitro Tire Inflator
350	Branick Nitro Wallmount Unit
P60	Branick N2 Hold Tank 60 Gallon
465	Branick Nitro Multi Inflator System
1000	Branick Nitro Truck Generator Standard
89TRL	Haltec Nitro Single Inflator System
89TRL - 4	Haltec Nitro Multi Inflator System
55 - 0069	Branick Nitrogen Analyzer
40 - 0065	Nitro Analyzer - N2 Sensor Replacement
N2 - HKC - 24	24' Green Nitro Air Hose With Chuck
N2 - HKC - 50	50' Green Nitro Air Hose With Chuck
N238 - 10	10' 3/8" Green Nitro Recoil Hose
N238 - 30	30' 3/8" Green Nitro Recoil Hose



89TRL - 4 1000



VHC75



3526



VHC78

ARO STYLE AIR LINE FITTINGS

Aro Type 1/4" Air Coupler With 1/4" N.P.T.

Code	Description
VHC75	Aro 1/4" Coupler - 1/4" Female N.P.T.
8888	Aro 1/4" Coupler - 1/4" Female N.P.T.
MIL - 775	Aro 1/4" Coupler - 1/4" Female N.P.T.
3526	Aro 1/4" Coupler - 1/4" Female N.P.T.
VHC77	Aro 1/4" Nipple - 1/4" Male N.P.T.
VHC78	Aro 1/4" Nipple - 1/4" Female N.P.T.

**FLEXZILLA HOSE***Rubber Air Hose. Made Of Heavy Duty 2 - Ply Hose. Resists Most Common Oils And Dirt In Shops. Rated For 300 Lbs. Working Pressure.*

Code	Description
HFZP1450YW2	Flexzilla 1/4" X 50ft Hose 1/4" N.P.T
HFZP1425YW2	Flexzilla 1/4" X 25ft Hose 1/4" N.P.T
HFZ14250YW	Flexzilla 1/4" X 250ft Hose - Bulk
HFZ38250YW	Flexzilla 3/8" X 250ft Hose - Bulk
HFZP3825YW2	Flexzilla 3/8" X 25ft Hose 1/4" N.P.T
HFZP3850YW2	Flexzilla 3/8" X 50ft Hose 1/4" N.P.T
HFZ12100YW3	Flexzilla 1/2" X 100ft With 3/8" N.P.T
HFZ12250YW	Flexzilla 1/2" X 250ft Hose - Bulk
HFZ1225YW3	Flexzilla 1/2" X 25ft With 3/8" N.P.T
HFZ1250YW3	Flexzilla 1/2" X 50ft With 3/8" N.P.T
RP900250	Flexzilla - 1/4" Reusable End
RP900250BS	Flexzilla - 1/4" Reusable End Ball SW

**HFZP1450YW2****LINCOLN STYLE AIR LINE FITTINGS***Lincoln Type 1/4" Air Coupler With 1/4" N.P.T.*

Code	Description
VHC90	Lincoln 1/4" Coupler - 1/4" Female N.P.T.
D123	Lincoln Style 1/4" Coupler 1/4" Female N.P.T.
13 - 434	Lincoln 1/4" Coupler - 1/4" Female N.P.T.
VHC91	Lincoln 1/4" Nipple - 1/4" Male
VHC92	Lincoln 1/4" Nipple - 1/4" Female

**VHC90****VHC91****HOSE FITTINGS AND ADAPTERS***Solid Brass Air Hose Barb Fittings.*

Code	Description
AH420	3/8" I.D. Hose Splice
AH430	Splicer Fitting 1/2"
AH130	Male Fitting 1/2"
AH132	Male Fitting 1/2"
AH232	Female Fitting 1/2" Swivel
AH450	Adapter 1/4" Male 3/8" Female
653 - 4	Adapter 3/8" Male 1/2" Female
AH451	Adapter 3/8" Male 1/4" Female
AH453	Adapter 1/2" Male 3/8" Female
AH462	Bushing 1/4" Male 1/4" Male
21 - 515	Reusable Hose Coupler 1/4" Female N.P.T. X 1/4" Female N.P.T.
122 - DB	Reducer Bushing 1/2" Male To 1/4" Male
647 - 2	Bushing 1/2" Male To 1/2" Male

**AH420****AH430****AH130**



INDUSTRIAL STYLE AIR LINE FITTINGS

Industrial Interchange Sleeve - Type

Code	Description		Size	Male or Female
VHC15	Industrial 1/4"	Coupler	1/4"	Female N.P.T.
MIL - 715	Industrial Milton	M - Style	1/4" Coupler - 1/4"	Female N.P.T.
MIL - 718	Milton M - Style 1/4"	Coupler	3/8" N.P.T.	Female
MIL - 755	Industrial Milton	M - Style	1/4" Push Coupler - 1/4"	Female
VHC27	Industrial 1/4"	Nipple	1/4"	Male
VHC28	Industrial 1/4"	Nipple	1/4"	Female
GP - 1760	Industrial 1/4"	Nipple	.305" - 3/2"	Female
MIL - 1833	Industrial	Coupler	3/8" - 1/4"	Female
C26 - 22	Industrial	Coupler	3/8" - 1/4"	Female
MIL - 1835	Industrial	Coupler	3/8" - 3/8"	Female
117	Industrial	Coupler	3/8" - 3/8"	Female
MIL - 1813	Industrial	Coupler	1/2 - 3/8"	Female
MIL - 1815	Industrial And Tru - Flate	Coupler	1/2" - 1/2"	Female
MIL - 1839	Industrial	Nipple	3/8" - 1/4"	Male
MIL - 1840	Industrial	Nipple	3/8" - 1/4"	Female
MIL - 1837	Industrial	Nipple	3/8" - 3/8"	Male
122	Industrial	Nipple	3/8" - 3/8"	Male
MIL - 1838	Industrial	Nipple	3/8" - 3/8"	Female
CP26 - 24	Industrial	Nipple	3/8" - 1/2"	Female
MIL - 1855	Industrial	Nipple	1/2" - 1/4"	Male
MIL - 1859	Industrial	Nipple	1/2" - 3/8"	Male
MIL - 1860	Industrial	Nipple	1/2" - 3/8"	Female
MIL - 1857	Industrial	Nipple	1/2" - 1/2"	Male
MIL - 1858	Industrial	Nipple	1/2" - 1/2"	Female
MIL - 731	Industrial	Nipple	1/4" - .035"	Female
MIL - 1805	Industrial	Nipple	3/8" - 3/8"	Female
MIL - 1809	Industrial	Nipple	3/8" - 1/4"	Male
MIL - 1807	Industrial	Nipple	3/8" - 3/8"	Male



VHC15



MIL - 755



VHC27



VHC28



117



122



MIL - 1858

BLOW GUNS

Combination Grip Blo - Gun

Code	Description
S - 166	Combination Grip Blo - Gun With 4" Extension
S - 167	Combination Grip Blo - Gun With 10" Extension



S - 166



208

Safety Blow Gun Hi - Volume. This Unit Features A Venturi Valve And Delivers Up To 16 CFM.

Code	Description
208	Safety Blow Gun Hi - Volume

**TRU - FLATE STYLE AIR LINE FITTINGS**

Code	Description	Size	Male or Female
VHC85	Tru - Flate 1/4" Coupler	1/4"	Female
D - 13R	Tru - Flate 1/4" Coupler	1/4"	Female
MIL - 787	Tru - Flate 1/4" Coupler	1/4"	Female
D - 15R	Tru - Flate 3/8" Coupler	1/4"	Female
D - 15R - 38	Tru - Flate 3/8" Coupler	3/8"	Female
VHC83	Tru - Flate 1/4" Nipple	1/4"	Male
VHC83B	Tru - Flate 1/4" Nipple	1/4"	Male
3506	Tru - Flate 1/4" Nipple	1/4"	Male
VHC84	Tru - Flate 1/4" Nipple	1/4"	Female
VHC84B	Tru - Flate 1/4" Nipple	1/4"	Female
D - 6C	Tru - Flate Connector	.305 - 32 Passenger Valve	
MIL - 779	Tru - Flate Connector	.305 - 32 Passenger Valve	
D - 7C	Tru - Flate Connector	.485 - 26 Short	
D - 7CR	Tru - Flate Connector	.485 - 26 2 - 1/4" L	
D - 7CRL	Tru - Flate Connector	.485 - 26 3 - 3/4" L	
VHC803	Tru - Flate 3/8" Heavy Duty Coupler	1/4"	Female
VHC805	Tru - Flate 3/8" Heavy Duty Coupler	3/8"	Female
VHC809	Tru - Flate 3/8" Nipple	1/4"	Male
VHC810	Tru - Flate 3/8" Nipple	1/4"	Female
VHC807	Tru - Flate 3/8" Nipple	3/8"	Male
VHC808	Tru - Flate 3/8" Nipple	3/8"	Female
VHC815	Tru - Flate 1/2" Heavy Duty Coupler	1/2"	Female
D - 17R	Tru - Flate 1/2" Heavy Duty Coupler	1/2"	Female
CO - 111R	Tru - Flate 1/2" Heavy Duty Coupler	1/2"	Female
VHC817	Tru - Flate 1/2" Nipple	1/2"	Male
MIL - 1817	Tru - Flate 1/2" Nipple	1/2"	Male
VHC818	Tru - Flate 1/2" Nipple	1/2"	Female
MIL - 1818	Tru - Flate 1/2" Nipple	1/2"	Female
3537	Tru - Flate 1/2" Nipple	3/8"	Male
MIL - 1819	Tru - Flate 1/2" Nipple	3/8"	Male
MIL - 1820	Tru - Flate 1/2" Nipple	3/8"	Female



VHC85



D - 13R



D - 15R - 38



3506



VHC808



VHC815



Jacks And Accessories



FLOOR JACKS

Code	Description
GT - G422500	2.5 Ton Gaither Low Profile Floor Jack
GT - G420300	3 Ton Gaither Double Pump Floor Jack
AME - 14350	4 Ton Lightweight Forklift Jack
AME - 14370	AME 7.5T Forklift Jack
GT - G420302	3 Ton Gaither Economy Floor Jack
10869	10 Ton A/H Floor Service Jack - Large Chassis



GT - G420300

AIR HYDRAULIC BOTTLE JACKS

Gaither Bottle Jacks

Code	Description
GT - G412000	20 Ton Bottle Jack
GT - G412001	20 Ton Bottle Jack Short
GT - G413000	30 Ton Bottle Jack



GT - G412000

Titan - 20 Ton Air Hydraulic Bottle Jack - Weld Base, Min 9.65" Max 18 - 1/2" Factory Tested At 150% Overload.

Code	Description
AME - 14460	20 Ton AME Air/Hydraulic Bottle Jack

20 Ton Gaither Air Hydraulic Bottle Jack - Welded Base. Features Chrome Main Ram And Aluminum Air Motor For Long Life. Air Filters Connected To Hose. Min Height 9.65 "(245 mm) Max Height 18.50 "(470 mm)

Code	Description
GT - G432020	20 Ton Gaither Air/Hydraulic Bottle Jack



www.ameintl.net
www.ameintl.net

AME - 14460

Titan - 20 Ton Air Hydraulic Cart Bottle Jack - Weld Base, Min 10 " Max 19" Factory Tested At 150% Overload. Includes A 36" Handle For Ease In Rolling Under Trucks And Buses. Chrome Ram And Aluminum Air Motor For Longer Life. Heavy Duty Return Springs.

Code	Description
AME - 14470	20 Ton AME Air Hydraulic Cart Bottle Jack



www.ameintl.net
www.ameintl.net

AME - 14470

Titan - 30 Ton Air Hydraulic Bottle Jack - Weld Base. Min 11" Max 18" Factory Tested At 150% Overload.

Code	Description
AME - 14475	30 Ton AME Air/Hydraulic Bottle Jack

OTR HEAVY DUTY SERVICE JACKS

55 Ton Aluminum Jack That Is Perfect For Off Highway Tire Work. The Unit Is Lightweight And Easy To Handle. Aluminum Base Plate. Can Be Used With Any 10,000 Psi Pump. Min Height 12 - 1/4" Max Height 18 - 1/4"

Code	Description
AME - 13120	55 Ton AME Low Aluminum Jack



- Made in Denmark for Over 55 Years
- High Tech Quality Production
- All Equipment is Factory Tested
- Worldwide Distribution to Over 50 Countries



**AC-DK20
AC-DK20Q**

2 1/4 T Floor Service Jack for Passenger Cars and Vans

Very low minimum height of only 80 mm. Rugged Steel Frame Construction. Precise and safe control while lowering. Built-in safety valve. Noiseless wheels incorporating a polyurethane central O ring offers maximum surface protection. Ergonomically designed handle ensuring positive and safe operation. AC-DK20Q fitted with quick-lift pedal for easy reach of lifting point (Option).



AC-B25-2

Portable Air Hydraulic 27.5T/11T Floor Jack – Ideal for Service Vans etc.

Low minimum height of only 160 mm and low weight of only 28 kg. Handy design - no loose tubes, handles or valves. Easy to operate – handle can be used for carrying, lifting, lowering and manoeuvring. Hard chromium plated piston rod for long life. Built-in safety overload valve. Transport locking device / wall bracket for both van and workshop (Option). 2 extensions (50/100 mm) available.



**AC-25-2
AC-25-2TH**

Versatile 25T/10T 2-Stage Air Hydraulic Jack for Buses and Trucks

Minimum height of 180 mm. Designed for heavy-duty, intensive commercial use. Hard chromium plated piston rod for long life. Built-in safety overload valve. Also available in AC-25-2TH model with telescopic handle increasing the reach under the vehicle to 2125 mm ensuring safe and easy operation. 2 extensions (50/100 mm) available.



AC-WT1500

1.5T Mechanical Wheel Trolley for Tractors, Agricultural and Contractors' Machinery

Ergonomically designed for the easy and efficient removal of large wheels - also deep-treaded tractor tires. Side-adjustable lifting arms for wheel diameters ranging 920-2300 mm. Robust safety wheel retaining bracket for the safe manoeuvring of the trolley. Precise and easy lifting and lowering by means of mechanical operation. Lifting arms fitted with 3 roller bearings for ensuring the easy location of wheels.



**AC-50-2
AC-50-2TH**

50T/25T 2-Stage Air Hydraulic Jack for Heavy Buses and Trucks

Minimum height of 220 mm. Designed for heavy-duty, intensive commercial use. Hard chromium plated piston rod for long life. Built-in safety overload valve. Also available in AC-50-2TH model with telescopic handle increasing the reach under the vehicle to 2170 mm ensuring safe and easy operation. 2 extensions (50/100 mm) available.

PRODUCT LINE

- Hydraulic Jacks • Air Hydraulic Jacks • Pit Jacks
 Jacking Beams • Heavy Duty Jacking Beams for Lifts
 Fold-Away Cranes • Heavy Duty Commercial Cranes
 Transmission Jacks • Wheel Trolleys • Axle Stands
 Presses • Bottle Jacks • Lifting Equipment for Aircraft

Contact your Prema Distributor For More Information





OTR HEAVY DUTY SERVICE JACKS

55 Ton Aluminum Jack That Is Perfect For Off Highway Tire Work. The Unit Is Lightweight And Easy To Handle. Aluminum Base Plate. Can Be Used With Any 10,000 Psi Pump. Min Height 16 - 1/4" Max Height 26 - 1/4"

Code **Description**
AME - 13140 55 Ton AME Aluminum Jack



AME - 13140

100 Ton Aluminum Jack That Is Perfect For Off Highway Tire Work. The Unit Is Lightweight And Easy To Handle. Aluminum Base Plate. Can Be Used With Any 10,000 Psi Pump. Min Height 11 - 3/4" Max Height 17 - 3/4"

Code **Description**
AME - 13000 100 Ton AME Aluminum Jack



AME - 13000

100 Ton Aluminum Cylinder With Locking Collar. 6" Stroke 15.5 Low Height. Aluminum Lock Nut Provides Mechanical Load Holding For Extended Periods.

Code **Description**
AME - 13155 100 Ton AME Low Aluminum Jack



AME - 13155

150 Ton Double Acting Steel Jack. 8" Stroke And 13.60 " Low Height. Must Be Used With Double Acting Pump - AME - 15085 And 2 Hydraulic Hoses. Max Height 21.60 "

Code **Description**
AME - 13150 150 Ton AME Low Aluminum Jack

55 Ton Maxi - Lite Aluminum Jack. 6" Stroke With 10.75" Low Height. Lightweight And Durable. This Is More Like A Ram As There Is No Base.

Code **Description**
AME - 13520 50 Ton AME Low Aluminum Jack



100 Ton Hydraulic Bottle Jack - Enerpac. Unit Features A Safety Relief Valve To Prevent Overloading, Wiper Seals For Extended Life, Chrome Plating On Both Plungers. No Extension Screw. Min Height 12.20" Max Height 18.11" Stroke 5.91"

Code **Description**
EBJ100GC 100 Ton Enerpac Hydraulic Bottle Jack

100 Ton Hydraulic Bottle Jack - Enerpac. Unit Features A Safety Relief Valve To Prevent Overloading, Wiper Seals For Extended Life, Chrome Plating On Both Plungers. No Extension Screw. Min Height 12.20" (310 mm) Max Height 18.11" (460 mm) Stroke 5.91"

Code **Description**
SLJ10027 100 Ton Hydraulic Super Lift Mining Jack



SLJ10027



OTR HEAVY DUTY SERVICE JACKS

100 Ton Air Hydraulic Super Lift Jack - Mining. Power Drive System. Min Height 38" Max Height 65" Total Width 29" Frame Length 96" Handle Height 40" Cylinder Base 13" 851 Large Bores.

Code	Description
SLJ10038	100 Ton AME Super Lift Jack



150 Ton Air Hydraulic Super Lift Jack - Mining. Power Drive System. Min Height 27" Max Height 43" Total Width 29" Frame Length 96" Handle Height 40" Cylinder Base 15" 794 Large Bores.

Code	Description
SLJ15027	150 Ton AME Super Lift Jack



100 Ton Superlift Jack Stand. Heavy Duty Steel Plate To Ensure Longevity. 2 Extensions Supplied With Each Stand.

Code	Description
SLJS100	100 Ton Superlift Jack Stand
SLJST - 100	100 Ton Superlift Transporter
SLJS200	200 Ton Superlift Jack Stand
SLJST - 200	200 Ton Superlift Transporter



AIR HYDRAULIC SERVICE JACKS

22 Ton Floor Service Jack. Ideal For Low Profile, Heavy Duty Lifting. Air Hydraulic Operation. Low Operating Noise And Quick Lifting. Min Height 9" Max Height 20 - 1/4" Handle Length 43" Also Includes A 2" Extension And A 4" Extension

Code	Description
AME - 14140	22 Ton Air Hydraulic Jack



Air Hydraulic Floor Service Jack. This 2 - Stage Units Lifts Up To 25 Ton At 1st Stage And 10Ton At 2 - Stage. Standard Handle. Minimum Height Of 7". Maximum Height Of 14.6"

Code	Description
AME - 14160	Air Hydraulic 30T/15 Ton 2 Stage Jack With Standard Handle

Air Hydraulic Floor Service Jack. This 2 - Stage Jack Unit Lifts Up To 25 Ton At 1st Stage And 10 Ton At 2 - Stage . Standard Handle. Minimum Height Of 7". Maximum Height Of 14.6"

Code	Description
GT - 3531	Gaither 35 Ton Floor Service Jack
GT - 432005	22 Ton Air Hydraulic Floor Service Jack
GT - 4532	Gaither 45/20 Ton 2 - Stag Floor Jack
GT - G420225	Turbo Lift 2.5 Ton Floor Service Jack Low Pro
GT - G420303	3 Ton Gaither Turbo Floor Jack
GT - Y420500	5 Ton Hydraulic Floor Service Jack
GT - 3531 - B12	GT - 3531 Floor Service Jack - 80 mm Extension
GT - 3531 - B13	GT - 3531 Floor Service Jack - 40 mm Extension
GT - 3531 - B14	GT - 3531 Floor Service Jack - 20 mm Extension
GT - 3531 - A9	GT - 3531 Floor Service Jack - Adapter





PREMA CANADA

Got a question about a product?
Looking for something?

Contact Prema at 800.268.6311 or visit
www.premacanada.ca for answers!





AIR LIFT BAGS

13 Ton Aramid Air Bag - Lifts 10 Tons 5 - 7". Max Lifting Capacity Is 13.5 Tons. Dimensions 15" X 15" X 1" Kit Includes Single Unit Deadman Control, 20' Supply Hose And A Carrying Bag.

Code	Description
AME - 25100K	13 Ton AME 7" Aramid AirBag



AME - 25100K

22 Ton Aramid Air Bag - Lifts 15 Tons 6 - 7". Max Lifting Capacity Is 22.5 Tons. Dimensions 20In X 20In X 1" Kit Includes Single Unit Deadman Control, 20' Supply Hose And A Carrying Bag.

Code	Description
AME - 25110K	22 Ton AME 9" Aramid Air Bag



AME - 25110K

32 Ton Aramid Air Bag - Lifts 20 Tons 8" Max Lifting Capacity Is 31.5 Tons. Dimensions 21" X 25" X 1" Kit Includes Single Unit Deadman Control, 20' Supply Hose And A Carrying Bag

Code	Description
AME - 25120K	32 Ton AME 11" Aramid Air Bag



AME - 25120K

37 Ton Aramid Air Bag - Lifts 20 Tons 9" Max Lifting Capacity Is 37 Tons. Dimensions 16" X 42" X 1" Kit Includes Single Unit Deadman Control, 20' Supply Hose And A Carrying Bag

Code	Description
AME - 25130K	37 Ton AME 9" Aramid Air bag



AME - 25130K

70 Ton Aramid Air Bag - Lifts 40 Tons 10 - 12" Max Lifting Capacity Is 69 Tons. Dimensions 34" X 34" X 1" Kit Includes Single Unit Deadman Control, 20' Supply Hose And A Carrying Bag.

Code	Description
AME - 25150K	70 Ton Aramid Air Bag Kit - Max 18"



AME - 25150K

JACK STANDS

AME 3 Ton Pin Flat Top Jack Stand 1Pr. 3 Ton Capacity Per Stand. Flat Rubber Pad Tops. Zinc Plated To Prevent Rust. Min Height 13". Max Height 21 - 1/2".

Code	Description
AME - 14980	AME 3 Ton Pin Flat Top Jack Stands 1Pair



AME - 14980

AME 5 Ton Pinned Jack Stands 1 Pair. European Design Accommodates Many Truck Axles. Anodized Finish. 5 Pin Placements. Capacity Is 5 Ton Per Stand. Sold In Pairs. Min Height 13" Max Height 21 - 1/2"

Code	Description
AME - 14720	AME 5 Ton Pinned Jack Stands 1 Pair



AME - 14720



JACK STANDS

AME 22 Ton Pinned Jack Stands 1 Pair. Sturdy, Welded Steel Construction For Superior Safety And Strength. Capacity Is 11 Ton Per Stand. Min Height 9.5 In. Max Height 19.9 In.

Code	Description
AME - 14360	AME 9 Ton Pinned Jack Stands - Pair



AME - 14360

AME 22 Ton Pinned Jack Stands 1 Pair. Sturdy, Welded Steel Construction For Superior Safety And Strength. Capacity Is 11 Ton Per Stand. Min Height 9.5" Max Height 19.9"

Code	Description
AME - 14400	AME 22 Ton Pinned Jack Stands - 1 Pair



AME - 14400

OTR HEAVY DUTY CRIBBING AND STANDS

Steel Crib Kit - 3Pc. Makes Lifting Easier As They Can Be Used Individually Or Stacked Together. They Will Not Slide. Made Of Heavy Duty Steel. To Be Used In Conjunction With 55 Ton Jacks. Included In Set Are 3", 6" And 9" High Stands

Code	Description
AME - 15002	Steel Crib Kit - 3-Piece Heavy Duty Steel



AME - 15002

Crib Stand - 3" . High Heavy Duty Steel. Durable And Will Not Bend Or Warp. Recessed Area On Cribbing Fits 7" Square Plate For 55 Ton Cylinders. Can Be Stacked With Other AME Steel Crib Stands.

Code	Description
AME - 15012	Crib Stand - 3" High Heavy Duty Steel



AME - 15012

Crib Stand - 6" . High Heavy Duty Steel. Durable And Will Not Bend Or Warp. Recessed Area On Cribbing Fits 7" Square Plate For 55 Ton Cylinders. Can Be Stacked With Other AME Steel Crib Stands.

Code	Description
AME - 15022	Crib Stand 6" High Heavy Duty Steel



AME - 15022

Crib Stand - 9" . High Heavy Duty Steel. Durable And Will Not Bend Or Warp. Recessed Area On Cribbing Fits 7" Square Plate For 55 Ton Cylinders. Can Be Stacked With Other AME Steel Crib Stands.

Code	Description
AME - 15032	Crib Stand 9" High Heavy Duty Steel



AME - 15032

30 Ton Non - Skid Jack Plate With Red Handle. Measures 12" X 12" X 1" Lightweight And Easy To Handle.

Code	Description
AME - 14464	30 Ton Non - Skid Jack Plate - Red



AME - 15032



OTR HEAVY DUTY CRIBBING AND STANDS

100 Ton Non - Skid Jack Plate With Yellow Handle. Measures 12" X 12" X 1.5" Lightweight And Easy To Handle.

Code	Description
AME - 14465	100 Ton Non - Skid Jack Plate - 12" x 12" x 15"



AME - 14465

100 Ton Non - Skid Jack Plate With Yellow Handle. Measures 24" X 24" X 2". Lightweight And Easy To Handle.

Code	Description
AME - 14468	100 Ton Non - Skid Jack Plate - 24" x 24" x 2"



AME - 14468

Industrial Cribbing Block - 10-Piece Set. Fr Industrial Version. Includes 6 - 15230, 3 - 15210 And 1 - 14465.

Code	Description
AME - 15255	Industrial Cribbing Block 10-Piece Set



AME - 15200

Industrial Cribbing Block - 2" X 4" X 18" And Black. Also Sold As Part Of The AME - 15250 9-Piece Set.

Code	Description
AME - 15200	Industrial Cribbing Block - Black - 2" x 4" x 18"

Industrial Cribbing Block - Black. Dimensions 4" X 4" X 18" Made Of 100% Recycled Plastic. Interlocking Or Aggressive Non - Slip Surface.

Code	Description
AME - 15210	Industrial Cribbing Block - Black - 4" x 4" x 18"



AME - 15210

Industrial Cribbing Block - Yellow. Dimensions 4" X 4" X 18" Made Of 100% Recycled Plastic. Interlocking Or Aggressive Non - Slip Surface.

Code	Description
AME - 15220	Industrial Cribbing Block - Yellow - 4" x 4" x 18"



AME - 15220

Industrial Cribbing Block - Yellow. Dimensions 6" X 7" X 24" Made Of 100% Recycled Plastic. Interlocking Or Aggressive Non - Slip Surface.

Code	Description
AME - 15230	Industrial Cribbing Block - Yellow - 6" x 7" x 24"

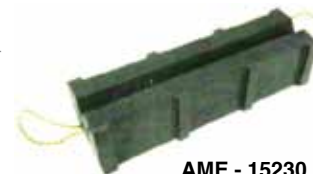

AME - 15230

Industrial Cribbing Block - Yellow. Dimensions 6" X 7" X 24" Made Of 100% Recycled Plastic. Interlocking Or Aggressive Non - Slip Surface.

Code	Description
AME - 15240	Industrial Cribbing Block - Yellow - 6" x 7" x 24"



AME - 15240

Industrial Cribbing Block - 9-Piece Set. Includes 3 - 15200, 3 - 15220 And 3 - 15230.

Code	Description
AME - 15250	Industrial Cribbing Block 9 - Piece Set

Industrial Cribbing Block - 12-Piece Set.

Code	Description
AME - 15260	Industrial Cribbing Block 12-Piece Set



Impact Sockets





1/2" SOCKETS AND SETS

1/2" Drive 13-Piece Deep Length Fractional Set.

Code **Description**

1312D 1/2" Drive 13-Piece Deep Length Fractional Set

CONTAINS 2014D - 7/16", 2016D - 1/2", 2018D - 9/16",
2020D - 5/8", 2022D - 11/16", 2024D - 3/4", 2026D -
13/16", 2028D - 7/8", 2030D - 15/16", 2032D - 1", 2034D - 1
- 1/16", 2036D - 1 - 1/8", 2040D - 1 - 1/4", 325CS - METAL
TRAY



1312D

Extra - Thin Wall Designed Deep Fractional And Metric Impact Sockets. The Extra - Thin Wall Design Allows Easy Access To Recessed Wheel Nuts Where Space Is Limited. Due To The Extra - Thin Wall Design, They Should Only Be Used On Wheel Nuts Where Limited Torque Is Applied. For Use Only With 1/2" Drive Tool. Do Not Use Reducing Adapters. Extra - Thin Wall Sockets Are Not Covered By Warranty

Code **Description**

1500DW 1/2" Drive 13-Piece Deep Length Fractional Set

CONTAINS SAE - 2024DT, 2026DT, 2028DT, 2032DT,
2034DT, 2146DT, AND METRIC 2017MDT, 2019MDT,
2021MDT, 2022MDT, 2023MDT, 2192MDT AND B1500DW
- C MOLDED CASE.



1500DW

1/2" Drive 13-Piece Standard Length Fractional Set.

Code **Description**

1312 1/2" Drive 13-Piece Standard Length Fractional Set

CONTAINS 2014R - 7/16", 2016R - 1/2", 2018R - 9/16",
2020R - 5/8", 2022R - 11/16", 2024R - 3/4", 2026R -
13/16", 2028R - 7/8", 2030R - 15/16", 2032R - 1", 2034R - 1
- 1/16", 2036R - 1 - 1/8", 2040R - 1 - 1/4", 206TR - METAL
TRAY



1319

This Set Includes Standard Length Fractional Sizes From 3/8" Through 1 - 1/2". The Set Is Packaged In A Convenient Molded Case With Handle For Easy Transportation. The Cover Of The Case May Be Removed To Allow The Bottom To Be Used As A Tool Box Organizer.

Code **Description**

1319 1/2" Drive 13-Piece Standard Length Fractional Set

19-Piece 1/2" DR SAE STANDARD SKT SET. FRAC-
TIONAL SIZES FROM 3/8IN THROUGH 1 - 1/2"

This Set Includes Standard Length Fractional Sizes From 3/8" Through 1 - 1/2". The Set Is Packaged In A Convenient Molded Case With Handle For Easy Transportation. The Cover Of The Case May Be Removed To Allow The Bottom To Be Used As A Tool Box Organizer.

Code **Description**

1412MD 1/2" Drive 14-Piece Deep Length Metric Set

CONTAINS 2010MD - 10MM, 2011MD - 11MM, 2012MD - 12MM,
2013MD - 13MM, 2014MD - 14MM, 2015MD - 15MM, 2016MD -
16MM, 2017MD - 17MM, 2018MD - 18MM, 2019MD - 19MM, 2021MD
- 21MM, 2022MD - 22MM, 2026MD - 26MM, 2027MD - 27MM,
207TR - METAL TRAY



1412MD

1/2" Drive Set Contains Deep Length Fractional And Metric Sizes, Plus 2 Flip Sockets And Extension For Wheel Service, Packaged In A Molded Case For Easy Transport And Storage.

Code **Description**

1512DM 1/2" Drive 30-Piece Deep Length Fractional And Metric Set

CONTAINS 1312D SET PLUS 1412MD SET.
ALSO CONTAINS 2146DT - 3/4IN X 13/16IN FLIP
SOCKET, 2243E - 1/2IN DRIVE X 3IN EXTENSION
W/STEEL BALL, 2192DT - 19MM X 21MM FLIP
SOCKET AND B1512DM - C - MOLDED CASE



1512DM

1/2" Drive Set Includes 3 Of The Most Popular Metric Sizes. Extra - Thin Wall Impact Sockets Are Not Covered By Warranty.

Code **Description**

1503TP 1/2" Drive 3-Piece Extra - Thin Wall Wheel/Nut Protector Set

SET CONTAINS THE 17MM, 19MM
AND 21MM SOCKETS.



1511TP

1/2" Drive 11-Piece Extra - Thin Wall Wheel/Nut Protector Set

Code **Description**

1511TP 1/2" Drive 11-Piece Extra - Thin Wall Wheel/Nut Protector Set

SET CONTAINS 11-Piece Extra
THIN WALL PROTECTOR IMPACT
SOCKETS. 3/4", 13/16", 7/8", 15/16",
1", 1 - 1/16", 17MM, 19MM, 21MM,
22MM, 23MM

**1/2" SOCKETS AND SETS**

Extra - Thin Wall Designed Deep 1/2" Impact Sockets. The Extra - Thin Wall Design Allows Easy Access To Recessed Wheel Nuts Where Space Is Limited. Due To The Extra - Thin Wall Design, They Should Only Be Used On Wheel Nuts Where Limited Torque Is Applied. For Use Only With 1/2" Drive Tool. Do Not Use Reducing Adapters. Extra - Thin Wall Sockets Are Not Covered By Warranty.

Code	Description	Size
2028D	1/2" Drive Fractional 6 Point Deep	7/8" HEX
2024D	1/2" Drive Fractional 6 Point Deep	3/4" HEX
2026D	1/2" Drive Fractional 6 Point Deep	13/16" HEX
2040D	1/2" Drive Fractional 6 Point Deep	1 - 1/4" HEX
2032D	1/2" Drive Fractional 6 Point Deep	1" HEX
2042D	1/2" Drive Fractional 6 Point Deep	1 - 5/16" HEX
2030D	1/2" Drive Fractional 6 Point Deep	1 - 5/16" HEX
2036D	1/2" Drive Fractional 6 Point Deep	1 - 1/8" HEX
2038D	1/2" Drive Fractional 6 Point Deep	1 - 3/16" HEX
2034D	1/2" Drive Fractional 6 Point Deep	1 - 1/16" HEX
2048D	1/2" Drive Fractional 6 Point Deep	1 - 1/2" HEX
2022D	1/2" Drive Fractional 6 Point Deep	11/16" HEX
2052D	1/2" Drive Fractional 6 Point Deep	1 - 5/8" HEX



2028D



2034D



2032D



2033MD



2114MD



2024DT

Extra - Thin Wall Designed Deep Fractional And Metric Impact Sockets. The Extra - Thin Wall Design Allows Easy Access To Recessed Wheel Nuts Where Space Is Limited. Due To The Extra - Thin Wall Design, They Should Only Be Used On Wheel Nuts Where Limited Torque Is Applied. For Use Only With 1/2" Drive Tool. Do Not Use Reducing Adapters. Extra - Thin Wall Sockets Are Not Covered By Warranty.

Code	Description	Size
2021MD	1/2" Drive Metric 6 Point Deep	21 mm HEX
2019MD	1/2" Drive Metric 6 Point Deep	19 mm HEX
2022MD	1/2" Drive Metric 6 Point Deep	22 mm HEX
2033MD	1/2" Drive Metric 6 Point Deep	33 mm HEX
2017MD	1/2" Drive Metric 6 Point Deep	17 mm HEX
2018MD	1/2" Drive Metric 6 Point Deep	18 mm HEX
2020MD	1/2" Drive Metric 6 Point Deep	20 mm HEX
2015MD	1/2" Drive Metric 6 Point Deep	15 mm HEX
2024MD	1/2" Drive Metric 6 Point Deep	24 mm HEX
2016MD	1/2" Drive Metric 6 Point Deep	16 mm HEX
2117MD	1/2" Drive Metric 12 Point Deep	17 mm HEX
2114MD	1/2" Drive Metric 12 Point Deep	14 mm HEX
2030MD	1/2" Drive Metric 6 Point Deep	30 mm HEX

These Extra - Thin Wall Deep Impact Sockets Are Designed To Allow Easy Access To Recessed Wheel Nuts Where Space Is Limited. Due To The Extra - Thin Wall Design, They Should Be Used Only On Passenger And Light Truck Wheel Nuts. Use Only With 1/2" Drive Tools. Do Not Use With Reducing Adapters. Extra - Thin - Wall Sockets Are Not Covered By Warranty.

Code	Description	Size
2024DT	1/2" Drive Extra - Thin Wall Deep Fractional	3/4"
2026DT	1/2" Drive Extra - Thin Wall Deep Fractional	13/16"
2028DT	1/2" Drive Extra - Thin Wall Deep Fractional	7/8"
2017MDT	1/2" Drive Extra - Thin Wall Deep Metric	17 mm
2019MDT	1/2" Drive Extra - Thin Wall Deep Metric	19 mm
2021MDT	1/2" Drive Extra - Thin Wall Deep Metric	21 mm



1/2" SOCKETS AND SETS

These Unique Extra - Thin Wall Impact Sockets Are For Use On Alloy Wheels With Decorative Lug Nuts. They Feature Protective (Color - Coded) Plastic Sleeves And Internal Plastic Inserts To Prevent Damage To Expensive Alloy Wheels And Decorative Lug Nuts. They Should Be Used Only On Passenger And Light Truck Wheel Nuts. Use Only With 1/2" Drive Air Tools. Do Not Use Reducing Adapters. Extra - Thin Wall Impact Sockets Are Not Covered By Warranty.

Code	Description	Size
2024TP	1/2" Drive Extra - Thin Wall Fractional Protector	3/4"
2026TP	1/2" Drive Extra - Thin Wall Fractional Protector	13/16"
2028TP	1/2" Drive Extra - Thin Wall Fractional Protector	7/8"
2030 TonP	1/2" Drive Exrta - Thin Wall Fractional Protector	15/16"
2021MTP	1/2" Drive Extra - Thin Wall Metric Protector	21 mm
2022MTP	1/2" Drive Extra - Thin Wall Metric Protector	22 mm
2019MTP	1/2" Drive Extra - Thin Wall Metric Protector	19 mm



2024TP

These Extra - Thin Wall Deep Impact Sockets Are Designed To Allow Easy Access To Recessed Wheel Nuts Where Space Is Limited. Due To The Extra - Thin Wall Design, They Should Be Used Only On Passenger And Light Truck Wheel Nuts. Use Only With 1/2" Drive Tools. Do Not Use With Reducing Adapters. Extra - Thin - Wall Sockets Are Not Covered by Warranty.

Code	Description	Size
2146DT	1/2" Drive Extra - Thin Wall Fractional Flip Socket	3/4"x13/16"
2192DT	1/2" Drive Extra - Thin Wall Metric Flip Socket	19 mm x 21 mm
2346D	1/2" Drive Thin Wall Fractional Flip Socket	3/4" x 13/16"
2392D	1/2" Drive Thin Wall Metric Flip Socket	19 mm x 21 mm
2349D	1/2" Drive Thin Wall Fractional Flip Socket	7/8" x 15/16"
2351D	1/2" Drive Thin Wall Fractional Flip Socket	1" x 1 - 1/16"
29106M	1/2" Drive x 10 mm	6" HEX Driver
29146M	1/2" Drive x 14 mm	6" HEX Driver
29206F	1/2" Drive x 5/8"	6" L HEX Driver
29246F	1/2" Drive X 3/4"	6" L HEX Driver
2018XD	1/2" Drive SAE 6PNT	9/16" X - Deep



2146DT



2238A

Reducing Adapters.

Code	Description	Size
2228A	1/2" Drive Fiction Ball Adapter	1/2" x 3/8"
2238A	1/2" Drive Friction Ball Adapter	1/2" x 3/4"



2243E

Reducing Adapters.

Code	Description
2243E	1/2" Drive 3" Friction Ball Extension
2245E	1/2" Drive 5" Friction Ball Extension
2247E	1/2" Drive 7" Friction Ball Extension
2210E	1/2" Drive 10" Friction Ball Extension
2269EL	1/2" Drive 24" Extra Long Extension With Locking Pin
2058D	1/2" Drive SAE 6 Point Deep 1 - 13/16"



2245E



3/4" SOCKETS AND SETS

A Complete 3/4" Drive Set Designed For Servicing Truck Wheels.

Code	Description
8032	3/4" Drive 11-Piece Drive Truck Wheel Service Set

11-Piece 3/4" DR. TRK. WHEEL SERV. IMPACT SOCKET SET - DEEP. HAS 3042D - 3/4", 3026D - 13/16", 3028D - 7/8", 3032D - 1", 3034DT - 1 - 1/16" TW, 3036DT - 1 - 1/8" TW, 3038D - 1 - 3/16", 3040DT - 1 - 1/4" TW, 3033MD - 33MM, 3048DB - 1 - 1/2" BUDD, 3313S - 13/16" SQ. STD, 899CS - METAL CASE



8032

Ten Of The Most Popular Fractional And Metric Impact Socket Sizes For Truck Wheel Fasteners.

Code	Description
8153	3/4" 10-Piece Drive Truck Socket Set

10-Piece 3/4" DR. TRK. WHEEL SERV. IMPACT SOCKET SET. HAS 3313S - 13/16" SQ., 3317S - 17MM SQ. 3321S - 21MM SQ., 3034DT - 1 - 1/16" TW, 3036DT - 1 - 1/8" TW, 3040DT - 1 - 1/4" TW, 3033MHD - 33MM DEEP HD, 3048DB - 1 - 1/2" BUDD, 3035MD - 35MM DEEP, 3041MD - 41MM DEEP, 899CS - METAL CASE



8153

Ten Of The Most Popular Fractional And Metric Impact Socket Sizes For Truck Wheel Fasteners.

Code	Description
8034D	3/4" Drive 8 Piece Fractional Deep Set

8-Piece 3/4" DRIVE DEEP IMPACT SAE SOCKET SET. CONTAINS 3032D - 1", 3034D - 1 - 1/16", 3036D - 1 - 1/8", 3040D - 1 - 1/4", 3042D - 1 - 5/16", 3044D - 1 - 3/8", 3046D - 1 - 7/16", 3048D - 1 - 1/2", 510CS - METAL CASE.



8034D

3/4" Drive Metric Deep 33 mm.

Code	Description
3033M	3/4" Drive Metric Standard Length 33 mm



3033M

3/4" Deep Sockets SAE.

Code	Description	Size
3048D	3/4" Drive Fractional Deep	1 - 1/2"
3040D	3/4" Drive Fractional Deep	1 - 1/4"
3038D	3/4" Drive Fractional Deep	1 - 3/16"
3046D	3/4" Drive Fractional Deep	1 - 7/16"
3030D	3/4" Drive Fractional Deep	15/16"
3024D	3/4" Drive Fractional Deep	3/4"
3026D	3/4" Drive Fractional Deep	13/16"
3028D	3/4" Drive Fractional Deep	7/8"
3032D	3/4" Drive Fractional Deep	7/8"
3034D	3/4" Drive Fractional Deep	1 - 1/16"
3036D	3/4" Drive Fractional Deep	1 - 1/8"
3042D	3/4" Drive Fractional Deep	1 - 5/16"
3044D	3/4" Drive Fractional Deep	1 - 3/8"



3048D

3/4" Deep Sockets Metric.

Code	Description	Size
3030MD	3/4" Drive Metric Deep	30 mm
3041MD	3/4" Drive Metric Deep	41 mm
3036MD	3/4" Drive Metric Deep	36 mm
3028MD	3/4" Drive Metric Deep	28 mm
3029MD	3/4" Drive Metric Deep	29 mm
3038MD	3/4" Drive Metric Deep	38 mm



3041MD



3/4" SOCKETS AND SETS

Designed For Truck Wheel Service When Removing Lug Nuts That Are Deeply Recessed And Where Space Is Very Limited.

Code	Description
3036DT	3/4" Drive SAE x Deep 1 - 1/8" Thin
3040DT	3/4" Drive SAE x Deep 1 - 1/4" Thin
3142D	3/4" Drive SAE x Deep 12 Pt Deep 1 - 5/16"



3036DT

Removes And Installs Budd - Type Wheel Fasteners. Sockets Have Two Openings, Eliminating The Need For Two Separate Sockets. Fractional And Metric Sizes.

Code	Description
3223C	3/4" Drive Combo Fractional Budd Wheel Socket 1 - 12" HEX X 13/16" Square
3241MC	3/4" Drive Combo Metric Budd Wheel Socket 41 mm HEX X 21 mm Square



3223C

Designed Specifically For Inner Bud - Style Square Fasteners On Truck Wheels.

Code	Description
3313S	3/4" Drive Fractional 4 Point Standard Length 13/16" Square
3313SHD	3/4" Drive Fractional 4 Point Heavy Duty Square 3/16"



3313SHD

Reducing Adapters Are Not Covered By Warranty.

Code	Description
3008A	3/4" Drive Adapter 3/4" Female X 1/2" With Friction Ball
3009A	3/4" Drive Adapter 3/4" Female X 1" With Pin Hole
3009AB	3/4" Drive Adapter 3/4" Female X 1" With Friction Ball
3009AL	3/4" Drive Adapter 3/4" Female X 1" With Locking Pin



3008A

3/4" Drive 3" Extension With Friction Ball.

Code	Description
3003EB	3/4" Drive 3" Extension With Friction Ball
3003EL	3/4" Drive 3" Extension With Locking Pin
3007E	3/4" Drive 7" Extension With Pin Hole
3010E	3/4" Drive 10" Extension With Pin Hole
3010EB	3/4" Drive 10" Extension With Friction Ball
3013EB	3/4" Drive 13" Extension With Friction Ball



3003EL

1" SOCKETS AND SETS

A Complete 1" Drive Set Designed For Servicing Truck Wheels. It Contains A 13/16" Square Size For Budd Wheel Inner Cap Nuts, 1 1 - 1/2" Outer Budd Nut Size That Has A "Controlled Depth" HEX End To Help Prevent Contact With The Wheel, A 33 mm Size For 10 Hole Hub Piloted Wheels, Three Deep Thin Wall Sizes And Other Regular Length Impact Sockets.

Code	Description
9152	1" Drive 10-Piece Drive Wheel Service Set

SET. CONTAINS 4313S - 13/16" SQ, 4028R - 7/8, 4030R - 15/16, 4032R - 1 IN., 4038R - 1 - 3/16, 4033MD - 33MM DEEP, 4034DT - 1 - 1/16 TW DEEP, 4036DT - 1 - 1/8 TW DEEP, 4040DT TW DEEP, 4048DB - 1 - 1/2 DEEP BUDD, 899CS - METAL CASE



9152



1" SOCKETS AND SETS

Ten Of The Most Popular Fractional And Metric Impact Socket Sizes For Truck Wheel Fasteners.

Code	Description
9153	1" Drive 10-Piece Drive Wheel Service Set

10-Piece E 1" DRIVE H.D. TRUCK SAE IMPACT SOCKET SET. CONTAINS 4313S - 13/16" SQ, 4315S - 15/16" SQ, 4032D - 1" DP, 4033MD - 33MM DP, 4034DT - 1 - 1/16" TW DP, 4036DT - 1 - 1/8" TW DP, 4038D - 1 - 3/16" DP, 4040DT - 1 - 1/4" TW DP, 4048D - 1 - 1/2" DP, 4056D - 1 - 3/4" DP, 899CS - METAL CASE



9153

A 1" Drive Deep Set Designed For Servicing Medium And Heavy Duty Truck Wheels.

Code	Description
9151	1" Drive 10-Piece Heavy Duty Wheel Service Set

10 PCE 1" DRIVE H.D. TRUCK SAE IMPACT SOCKET SET. CONTAINS 4313S - 13/16" SQ, 4315S - 15/16" SQ, 4032D - 1" DP, 4033MD - 33MM DP, 4034DT - 1 - 1/16" TW DP, 4036DT - 1 - 1/8" TW DP, 4038D - 1 - 3/16" DP, 4040DT - 1 - 1/4" TW DP, 4048D - 1 - 1/2" DP, 4056D - 1 - 3/4" DP, 899CS - METAL CASE



9151

This Set Contains Impact Sockets Designed To Fit Large Truck And Off - The - Road Wheel Fasteners.

Code	Description
9161D	1" Drive 9-Piece Large Truck Wheel/ OTR Wheel Service Set

9-Piece 1IN DRIVE LARGE TRUCK And OTR IMPACT SOCKET SET. CONTAINS 4313S - 13/16IN SQ, 4315S - 15/16IN SQ, 4033MD - 33MM DP, 4048D - 1 - 1/2IN DP, 4052D - 1 - 5/8IN DP, 4056D - 1 - 3/4IN DP, 4060D - 1 - 7/8IN DP, 4064D - 2IN DP, 4072D - 2 - 1/4IN DP, 707CS - METAL CASE.



This Set Contains Impact Sockets Designed To Fit Large Truck And Off - The - Road Wheel Fasteners.

Code	Description	Size
4033M	1" Drive Standard Length Metric	33 mm



4033M

1" Drive Deep SAE Impact Sockets Designed To Fit Large Truck And Off - The - Road Wheel Fasteners.

Code	Description	Size
4024D	1" Drive Fractional Deep	3/4"
4034D	1" Drive Fractional Deep	1 - 1/16"
4036D	1" Drive Fractional Deep	1 - 1/8"
4038D	1" Drive Fractional Deep	1 - 3/16"
4040D	1" Drive Fractional Deep	1 - 1/4"
4042D	1" Drive Fractional Deep	1 - 5/16"
4044D	1" Drive Fractional Deep	1 - 3/8"
4046D	1" Drive Fractional Deep	1 - 7/16"
4048D	1" Drive Fractional Deep	1 - 1/2"
4050D	1" Drive Fractional Deep	1 - 9/16"
4052D	1" Drive Fractional Deep	1 - 5/8"
4054D	1" Drive Fractional Deep	1 - 3/4"
4155MD	1" Drive Fractional Deep	1 - 13/16"
4246D	1" Drive Fractional Deep	1 - 15/16"



4024D



4040D



4030MD

1" Drive Deep Metric Impact Sockets Designed To Fit Large Truck And Off - The - Road Wheel Fasteners.

Code	Description	Size
4030MD	1" Drive Metric Deep	30 mm
4033MD	1" Drive Metric Deep	33 mm
4035MD	1" Drive Metric Deep	35 mm
4036MD	1" Drive Metric Deep	36 mm
4038MD	1" Drive Metric Deep	38 mm
4030MD	1" Drive Metric Deep	41 mm

**1" SOCKETS AND SETS**

Code	Description	Size
4036DT	1" Drive Fractional Extra - Deep Thin - Wall	1 - 1/8"
4040DT	1" Drive Fractional Extra - Deep Thin - Wall	1 - 1/4"
4042DT	1" Drive Fractional Extra - Deep Thin - Wall	1 - 5/16"
4048DT	1" Drive Fractional Extra - Deep Thin - Wall	1 - 1/2"
4054D	1" Drive SAE 6 Point DEEP	1 - 11/16"
4155MD	1" Drive X 55 mm Deep 12 Point SKT	
4246D	1" Drive X 1 - 7/16" Deep 12 Point SKT	



4036DT

Code	Description	Size
4035MDT	1" Drive Metric Extra - Deep Thin - Wall	35 mm
4041MDT	1" Drive Metric Extra - Deep Thin - Wall	41 mm



4041DT

Special 1 - 1/2" Hex Deep Heavy Duty Impact Socket Designed For Outer Cap Nuts On Budd - Style Truck Wheels. The 1 - 1/2" Hex Depth Is Limited To Help Prevent Socket Contact With The Wheel. The Socket Is Deep Style To Eliminate Contact With The Inner Cap Nut.

Code	Description	Size
4048DB	1" Drive Deep Fractional Budd Wheel Socket Limited	HEX 1 - 1/2"



4048DB

Sockets Remove And Installs Budd - Type Wheel Fasteners. Sockets Have Two Openings, Eliminating The Need For Two Separate Sockets. Fractional And Metric Sizes.

Code	Description	Size
4223C	1" Drive Fractional Combo Budd Wheel Socket	1 - 1/2" H X 13/16" Square
4241MC	1" Drive Metric Combo Budd Wheel Socket	41 mm X 21 mm



4223C

Sockets Designed Specifically For Inner Budd - Style Square Fasteners On Truck Wheels.

Code	Description	Size
4313S	1" Drive Fractional 4 Point Square Standard Length	13/16"
4315S	1" Drive Fractional 4 Point Square Standard Length	15/16"
4317S	1" Drive Metric 4 Point Square Standard Length	17 mm
4319S	1" Drive Metric 4 Point Square Standard Length	19 mm
4321S	1" Drive Metric 4 Point Square Standard Length	21 mm
4313SHD	1" Drive Fractional 4 Point Heavy Duty Square	13/16"



4313SHD

Reducing Adapters. Not Covered By Warranty.

Code	Description
4008A	1" Drive Adapter 1" Female X 3/4" Male With Pin Hole
4008AB	1" Drive Adapter 1" Female X 3/4" Male With Friction Ball



4008AB



1" SOCKETS AND SETS

1" Impact Extensions.

Code	Description
4007EL	1" Drive 7" Extension With Locking Pin
4010EL	1" Drive 10" Extension With Locking Pin
4013EL	1" Drive 13" Extension With Locking Pin



#5 SPLINE SOCKETS AND SETS

#5 Spline Drive Set Designed For Servicing Truck Wheels. It Contains A 13/16" Square Size For The Budd Wheel Inner Cap Nuts, A 1 - 1/2" Outer Budd Nut Size That Has A "Controlled Depth" Hex End To Help Prevent Contact With The Wheel, A 33 mm Size For 10 Hole Hub Piloted Wheels, Three Deep Thin - Wall Sizes And Other Regular Length Impact Sockets.

Code	Description
9263	#5 Spline 10-Piece Truck Wheel Set

Code	Description
8940166760	1/2" Drive Metric 3-Piece Deep Set



9263

Special 1 - 1/2" Hex Deep Heavy Duty Impact Socket Designed For Outer Cap Nuts On Budd - Style Truck Wheels. The 1 - 1/2" Hex Depth Is Limited To Help Prevent Socket Contact With The Wheel. The Socket Is Deep Style To Eliminate Contact With The Inner Cap Nut.

Code	Description	Size
5033M	#5 Spline Drive Metric Standard	33 mm



5033M

Special 1 - 1/2" Hex Deep Heavy Duty Impact Socket Designed For Outer Cap Nuts On Budd - Style Truck Wheels. The 1 - 1/2" Hex Depth Is Limited To Help Prevent Socket Contact With The Wheel. The Socket Is Deep Style To Eliminate Contact With The Inner Cap Nut.

Code	Description	Size
5033MD	#5 Spline Drive Metric Deep	33 mm



5033MD

Special 1 - 1/2" Hex Deep Heavy Duty Impact Socket Designed For Outer Cap Nuts On Budd - Style Truck Wheels. The 1 - 1/2" Hex Depth Is Limited To Help Prevent Socket Contact With The Wheel. The Socket Is Deep Style To Eliminate Contact With The Inner Cap Nut.

Code	Description	Size
5048DS	#5 Spline Drive Fractional Deep	1 - 1/2"
5008AB	#5 Spline Drive Adapter 3/4" Male With Friction Ball	



5048DS

Special 1 - 1/2" Hex Deep Heavy Duty Impact Socket Designed For Outer Cap Nuts On Budd - Style Truck Wheels. The 1 - 1/2" Hex Depth Is Limited To Help Prevent Socket Contact With The Wheel. The Socket Is Deep Style To Eliminate Contact With The Inner Cap Nut.

Code	Description	Size
5048DB	#5 Spline Drive Fractional Budd Wheel Limited HEX	1 - 1/2"



5048DB

#5 Spline Drive Fractional 4 Point Square 13/16".

Code	Description	Size
5313S	#5 Spline Drive Fractional 4 Point Square	13/16"



5313S



Air Inflation Tools And Accessories





DIGITAL AIR GAUGES

Standard Digital Tire Pressure Gauge. 5 - 99 Psi. Features An Easy To Read Display , Auto On Off, Easy Grip And Rugged Construction.

Code Description

40 - 710 Digital Passenger Pressure Gauge

Mechanical Digital Tire Pressure Gauge. 5 - 150 Psi Featuring An Easy To Read Display , Easy Grip And Rugged Construction. Lithium Battery Operated.

Code Description

40 - 720 Mechanical Digital Tire Pressure Gauge

Passenger Pressure Gauge. Digital Psi Setting Range 3.5 To 99.5 Psi. LCD Reading. Automatic Shut - Off. CE Approved. Improve Fuel Efficiency. Reduce Tire Wear And Extend Tire Life. Improve Vehicle Handling And Safety

Code Description

5900 Passenger Pressure Gauge - Digital

Unicheck Digital Truck Gauge. Digitally Reads Tire Pressure For Accuracy. Durable And Dependable. Reads Accurately From 0 - 180 Psi. Both Psi And Kpa Option.

Code Description

AME - 24145 Unicheck Digital Truck Gauge

Digital Universal Service Gauge. Has 4 Measurement Options - 0 - 170Psi / 0 - 12 Bar / 0 - 1200 Kpa / 0 - 12 kg/Cm

Code Description

DUSG1 Digital Universal Service Gauge

Digital Round Face Master Service Gauge That Can Be Used On Both Standard And Large Bore Valves. 0 - 200 Psi. Comes With A Plastic Carrying Case And Holds Pressure Reading.

Code Description

EX - 1235 Standard Bore/Large Bore Digital Tire Gauge

DIGITAL INFLATORS

Haltec Air Master Digital Inflator Gauge. Calibrated From 0 - 150 Psi In 0.5 Psi Increments. 6Ft Hose With Euro Style Chuck.

Code Description

I - 450 - 6 Digital Inflator Gauge - 6ft Hose

Digital Tire Inflation Gauge. Extremely Accurate 0 - 174 Psi In 0.2 Psi Increments. Lightweight And Shock Resistant. Includes A 6 Ft. Hose And Euro Chuck. 1/4" In N.P.T. Air Inlet. Widely Accepted For Checking TPMS Applications

Code Description

DAC1A08 PCL Digital Tire Inflation Gauge

Digital Inflation Gauge With 6 Ft Hose.

Code Description

H300532P PCL Digital Inflator Gauge With 6 ft Hose



40 - 710



40 - 720



5900



AME - 24145



DUSG1



I - 450 - 6



EX - 1235



H300532P



DAC1A08



STANDARD AIR GAUGES

Straight Push - On Standard Passenger Gauge. 4 - Sided Nylon Bar, 2 Sides Calibrated 5 - 50Lbs. In 1Lbs. Units. Other 2 Sides Kpa 40 - 350 In 10 Kpa Units. Manufactured In The USA .

Code Description

S - 923 Straight Push on Passenger Gauge



S - 923

Standard Passenger Gauge. 4 - Sided Nylon Bar, 2 Sides Calibrated 10 - 50Lbs. In 1Lbs. Units. Other 2 Sides Kpa 75 - 340..

Code Description

VH661 Standard Passenger Gauge



VH661

Angle Head Passenger Pocket Gauge. 4 Sided Nylon Bar With 2 Sides Calibrated 5 - 50Lbs In 2Lbs. Units. Other 2 Sides Are Calibrated 50 - 350 Kpa.

Code Description

2 - 220 Standard Passenger Gauge



2 - 220

Mid Range Pencil Gauge 10 - 75 Psi

Code Description

5600 - E Mid Range Pencil Gauge



5600 - E

Prema Mid Range Pencil Gauge 10 - 75 Psi. USA Made Product.

Code Description

5600 - Prema Pencil Gauge



5600 - Prema

Standard Passenger Gauge. 4 - Sided Nylon Bar, 2 Sides Calibrated 5 - 50Lbs In 1Lbs. Units. Other 2 Sides 40 - 350 Kpa In 10 Kpa Units.

Code Description

S - 921 Passenger Pencil Gauge



Car Tire Air Gauge Pack. Features 10 Individual Tire Gauges In An Attractive Point Of Purchase Display . A Super Counter Unit For Service Station And Tire Shop Owners. Calibrated 10 - 75 Lbs. In 1 Large Bore. Units.

Code Description

7277 Standard Bore Tire Gauge Disposable - 10pk



7277

LOW PRESSURE GAUGES

Low - Low Pressure Gauge. 4 - Sided Nylon Bar, 2 Sides Calibrated 1 - 20 Lbs. In 1/2Lbs. Units. Other 2 Sides Kpa 10 - 135.

Code Description

VH663 Low - Low Pressure Gauge



VH663

Low - Low Pressure Gauge. 4 - Sided Nylon Bar, 2 Sides Calibrated 1 - 20 Lbs. In 1 Lbs. Units. Other 2 Sides Kpa 20 - 140 In 10 Kpa Units. Manufactured In The USA .

Code Description

S - 917 Low - Low Pressure Gauge



S - 917

Dill Low - Low Pressure Gauge. Nylon Bar, Calibrated 1 - 20 Lbs In 1/2Lbs. Chrome Finish..

Code Description

7229 Low - Low Pressure Gauge



7229



TRUCK PENCIL GAUGES

Truck Pencil Gauge. 4 - Sided Nylon Bar, 2 Sides Calibrated 20 - 120 Lbs. In 2 Lbs. Units. Other 2 Sides Kpa 150 - 810.

Code Description

VH662 Truck Pencil Gauge



VH662

Pocket Style Truck Service Gauge. 4 Sided Nylon Bar That Is Calibrated 20 - 120 Lbs. In 2Lbs. Units On 2 Sides And 140 - 840 Kpa On The Other 2 Sides.

Code Description

2 - 223 Truck Pencil Gauge



2 - 223

Truck Pencil Gauge. 4 - Sided Nylon Bar, 2 Sides Calibrated 20 - 120 Lbs. In 2 Lbs. Units. Other 2 Sides 120 - 820 Kpa In 20 Kpa Units. Manufactured In The USA .

Code Description

S - 925 Truck Pencil Gauge



S - 925

TRUCK DUAL FOOT GAUGES

Dual Foot Short Truck Gauge On A Blister Card. These English Made Units Are Manufactured In Brass For Smooth Extrusion And Finished In A Heavy Duty Chrome Plating. They Have A Heavy Duty Metal Bar That Is Calibrated 10 - 120Lbs. In 2Lbs. Units.

Code Description

TPG4J05 Dual Foot Truck Angle Gauge



TPG4J05

Dual Foot Truck Gauge. 4 - Sided Nylon Bar, 2 Sides Calibrated 20 - 120Lbs. In 2Lbs Units. Other 2 Sides 150 - 810 Kpa.

Code Description

VH664 Dual Foot Truck Gauge



VH664

Dual Angle Foot Truck Pencil Gauge. High Pressure, High Quality Unit. 20 - 120Psi In 2Lbs. Units. Nylon Indicator Bar.

Code Description

7248 Dual Foot Truck Gauge



7248

Dual Foot Angle Short Truck Service Gauge. 4 Sided Nylon Bar. 2 Sides Calibrated 20 - 120Lbs. In 2Lbs. Units. Other 2 Sides Are 150 - 840 Kpa.

Code Description

2 - 224 Dual Foot Truck Gauge



2 - 224

Dual Foot Truck Gauge. 4 - Sided Nylon Bar, 2 Sides Calibrated 20 - 120Lbs. In 2Lbs. Units. Other 2 Sides 120 - 820 Kpa In 10 Kpa Units. Manufactured In The USA .

Code Description

S - 927 Dual Foot Truck Angle Gauge



S - 927

Premium Dual Foot Pocket Gauge. Tapered Head Design To Allow A Precise Fit When Checking Air Pressure. 4 Sided Nylon Bar, 2 Sides Calibrated 20 - 120Lbs. In 2Lbs. Units. Other 2 Sides Calibrated 150 - 810Kpa. Black and Silver Premium Finish.

Code Description

VHP664 Dual Foot Truck Angle Gauge



VHP664



TRUCK AIR GAUGES DUAL FOOT

Dual Foot Service Gauge. 2 - Sided Nylon Bar, One Side Calibrated 10 - 150 Lbs. In 2Lbs. Units. Calibrated At 10Lbs. Intervals. Other Side 80 - 1040 Kpa.

Code	Description
VH665	Dual Foot Service Gauge



Dual Foot Long Truck Service Gauge. Great For Servicing Tilted Inner Dual Valves. 2 - Sided Metal Indicator Bar. Calibrated 10 - 150Lbs. In 2Lbs. Units.

Code	Description
7275	Dual Foot Service Gauge



Dual Foot Long Truck Service Gauge. Great For Servicing Tilted Inner Dual Valves. 2 - Sided Metal Indicator Bar. Calibrated 10 - 150Lbs. In 2Lbs. Units. Recalibration Feature.

Code	Description
7275R	Dual Foot Service Gauge - Recalibratable



Dual Foot Long Service Gauge. 4 Sided Nylon Bar. 2 Sides Calibrated 10 - 130Lbs. In 2 Lbs. Units. Other 2 Sides 100 - 900 Kpa. Also Features A Ring To Hang The Gauge Up And Allow The Release Of Moisture.

Code	Description
2 - 228	Dual Foot Service Gauge



Dual Foot Service Gauge. 4 - Sided Nylon Bar, 2 Sides Calibrated 10 - 160Lbs In 2Lbs. Units. Other 2 Sides 80 - 1100 Kpa In 20 Kpa Units. Manufactured In The USA .

Code	Description
S - 976	Dual Foot Service Gauge



Premium Dual Foot Pocket Gauge. Tapered Head Design To Allow A Precise Fit When Checking Air Pressure. 4 Sided Nylon Bar, 2 Sides Calibrated 10 - 150Lbs. In 2Lbs. Units. Calibrated At 10Lbs. Interval With 5Lbs. Marker Between. Other 2 Sides 80 - 1040 Kpa.

Code	Description
VHP665	Dual Foot Service Gauge



Premium HD Metal Bar, Long Dual Foot Tire Service Gauge. Head Design To Allow A Precise Fit. 2 - Sided Metal Bar. 1 Side Calibrated 10 - 150Lbs. In 2Lbs. Units. Other Side 80 - 1040 Kpa. Black Finish.

Code	Description
VHP665M	Dual Foot Service Gauge



DIAL FACE GAUGES

Small Bore And Large Bore Dial Type Gauge. 0 - 160 Psi Features A Release Valve Button. Very Durable Product

Code	Description
EX - 1230	Standard Bore/Large Bore Air Liquid Gauge - Dial Type - 0 - 160
EX - 1240	Standard Bore/Large Bore Dial Gauge - 0 - 160



EX - 1230



DIAL FACE GAUGES

Standard And Large Bore Air Gauge With Non - Corrosive Inner Parts. Has 14" Flexible Hose With Straight Chuck. Recalibration Screw Permits Adjustments. 0 - 160Psi In 2Lbs. Units And 0 - 110 Kpa For Metric Pressures. Accurate To Within 2% Of Total Dial Range.

Code Description

8810 - J Standard Bore Air Liquid Gauge 0 - 160psi



8810 - J

Small Bore/Large Bore Air Liquid Gauge

Code Description

GA - 274 Standard Bore/Large Bore Air Liquid Gauge



GA - 274

Dial Face Air/Liquid Service Gauge That Can Be Used On Both Standard And Large Bore Valves. 0 - 200 Psi. 16" Hose. Comes With A Plastic Carrying Case And Is Also Recalibratable.

Code Description

EX - 1220 Standard Bore/Large Bore Air Liquid Gauge - Dial Type



EX - 1220

Dial Face Truck Gauge 0 - 160Psi. Holds Pressure Read Out Until Released. In 5Lbs. Increments

Code Description

N - 1055 Dial Face Truck Gauge



N - 1055

TRUCK AIR GAUGES

Straight Push - On 30 Degree Reverse Angle Service Gauge For Standard Bore Valves. 2 - Sided Nylon Bar. One Side Calibrated 20 - 150Lbs. In 2Lbs. Units. Other Side Calibrated 80 - 1040 Kpa.

Code Description

VH668 Straight Push On 30° Reverse Angle Service Gauge



VH668

This Gauge Has A Special 180 Degree Reverse Chuck To Accommodate The Small Hand Holes Found On Many Of Today's Truck Wheels. 10 - 150 Psi In 2Lbs. Increments.

Code Description

VH668 - R180 Long Service Gauge - 180 degree reverse Angle



VH668 - R180

Dual Straight Foot Service Gauge. Straight Chuck Used For Inner Duals. 30 Degree Reverse Angle Chuck For Outside Dual. 2 Sided Metal Indicator Bar. Calibrated 10 - 150Lbs. In 2Lbs. Units.

Code Description

7285 Straight Push on 30° Reverse Angle Service Gauge

7285R Recalibratable Service Gauge

7285E Recalibratable Service Gauge in 2 Psi Increments



7285

Dual Straight Foot Service Gauge. Straight Chuck Used For Inner Duals. 30 Degree Reverse Angle Chuck For Outside Dual. 4 - Sided Delrin Indicator Bar. Calibrated 10 - 150Lbs. In 2Lbs. Units On All 4 Sides.

Code Description

7125 - H Straight Push on 30° Reverse Angle Service Gauge



VHP668

Premium Long Tire Service Gauge. Straight Push - On And 30 Degree Reverse Angle End. Tapered Head Design To Allow A Precise Fit. 4 - Sided Metal Bar. 2 Sides Calibrated 10 - 150Lbs. In 2Lbs. Units. Other Sides 80 - 1040 Kpa. Black Finish.

Code Description

VHP668 Straight Push on 30° Reverse Angle Service Gauge



7125 - H



TRUCK AIR GAUGES

Premium HD Metal Bar, Long Tire Service Gauge. Straight Push - On And 30 Degree Reverse Angle End. Tapered Head Design To Allow A Precise Fit. 2 - Sided Metal Bar. 1 Side Calibrated 10 - 150Lbs. In 2Lbs. Units. Other Side 80 - 1040 Kpa. Black Finish.

Code Description

VHP668M Straight Push on 30° Reverse Angle Service Gauge



VHP668M

Straight Push - On 30 Degree Reverse Angle Short Truck Gauge. 4 - Sided Nylon Bar. 2 Sides Calibrated 20 - 120Lbs. In 2Lbs. Units. Other Sides 150 - 810 Kpa.

Code Description

VH669 Straight push 30°Reverse Angle Truck Gauge



VH669

Straight And 30 Degree Reverse Angle Truck Pencil Gauge. High Pressure, High Quality Unit. 20 - 120Psi In 2Lbs. Units. Nylon Indicator Bar.

Code Description

7278 Straight push 30°Reverse Angle Truck Gauge



7278

Straight On And 30 Degree Reverse Angle Short Truck Service Gauge. 4 Sided Nylon Bar. 2 Sides Calibrated 20 - 120Lbs. In 2Lbs. Units. Other 2 Sides Are 150 - 840 Kpa.

Code Description

2 - 224S Straight Push 30° Reverse Angle Truck Gauge



2 - 224S

Straight Push 30 Deg Reverse Angle Truck Gauge. Calibrated 20 - 120 Psi In 2Lbs Increments. Nylon Bar. Chrome Finish.

Code Description

GA - 150 Straight Push 30° Reverse Angle Truck Gauge



GA - 150

Straight Push - On 30 Degree Reverse Angle Short Truck Gauge. 4 - Sided Nylon Bar. 2 Sides Calibrated 20 - 120Lbs. In 2Lbs. Units. Other Sides 120 - 820 Kpa In 20 Kpa Increments. USA Made.

Code Description

S - 929 Straight Push 30° Reverse Angle Truck Gauge



S - 929

Premium Short Tire Service Gauge. Straight Push - On And 30 Degree Reverse Angle End. Tapered Head Design To Allow A Precise Fit. 4 - Sided Nylon Bar. 2 Sides Calibrated 20 - 120Lbs. In 2Lbs. Units. Other Sides 150 - 810 Kpa. Black Finish.

Code Description

VHP669 Straight Push 30° Reverse Angle Truck Gauge



VHP669

AIR LIQUID GAUGES

Air Liquid Tractor Gauge For Air And Liquid Filled Tires. 4 - Sided Nylon Bar. 2 Sides Calibrated 5 - 50Lbs. In 1Lbs. Units. Other Sides 35 - 310 Kpa.

Code Description

VH660 Air/Liquid Gauge



VH660

Air Liquid Service Gauge. 4 Sided Nylon Bar With A Heavy Duty Spring. All 4 Sides Calibrated 5 - 40Lbs. In 2Lbs. Units.

Code Description

2 - 222 Air/Liquid Gauge



2 - 222



AIR LIQUID GAUGES

Air Liquid Tractor Gauge For Air And Liquid Filled Tires. 4 - Sided Nylon Bar. 2 Sides Calibrated 5 - 50Lbs. In 2Lbs. Units. Other Sides 40 - 350 Kpa. In 10 Kpa Units. Milton Air Gauges Are Manufactured In The USA

Code	Description
S - 928	Air/Liquid Pencil Gauge - Milton



S - 928

Has Non Corrosive Inner Parts. Dial Gauge Calibrated 0 - 100Psi In 1Lbs. Units And 0 - 700 Kpa For Metric Pressures. Has A 7" Flexible Hose With Swivel Chuck. Gauge Is Accurate To Within 2% Of Total Dial Range.

Code	Description
8810 - H	Tractor Air/Liquid Gauge 0 - 100psi

DIAL INFLATORS

Haltec Air Master Dial Gauge With Ergonomic Design That Makes The Gauge Comfortable To Operate And Easy To Use. One Button Inflate/ Deflate. 4 - 140 Psi In 2Lbs Increments. Protected By Rubber Shroud. 6' Hose With Lock - On Chuck.

Code	Description
I - 430 - 6	Dial Gauge Inflator 6ft With Chuck



1960

Dial Type Gauge 0 - 160 Psi In 2Lbs Increments. Angled Single Head Chuck.

Code	Description
S - 903	Mini Dial Gauge With Bleeder



1991

Eurodainu Gauge - Small Dial Face. High Visibility, Accuracy And Durability Are Important Factors. Calibrated 10 - 170 Psi In 2Lbs Increments And 0.7 To 12 Bar. Comes Standard With A 1.5 Meter Hose And A Euro Style Clip - On Chuck.

Code	Description
1960	Eurodainu Gauge - Small Dial Face



1995

Dial Type Air Line Service Gauge. Designed For Use When High Visibility, Accuracy And Durability Are Important Factors. Calibrated 10 - 170 Psi In 2 Lbs. Increments And 0.7 To 12 Bar. Comes Standard With A 1.5 Meter Hose And A Euro Style Clip - On Chuck.

Code	Description
1991	Eurodainu Gauge - Michelin Type



1991 - HS&CK

Eurodainu Race Car Inflation Gauge. Dual Graduated Easy To Read Dial Face. 7 - 50 Psi And 0.5 - 3.5 Bar. 24" (60 Cm) Hose With Euro Chuck.

Code	Description
1995	Eurodainu Race Car Inflation Gauge

1991 Gauge Hose And Chuck. This Is The Replacement Hose And Chuck For The Michelin Eurodainu Gauge. Also Includes The Special Euro Fitting To Go Into The Gauge Body.

Code	Description
1991 - HSAND CK	Hose And Chuck For 191 Gauge



H310532P

Analog Inflation Gauge With 6 Ft Hose.

Code	Description
H310532P	Analog Inflator Gauge With 6 ft hose



DIAL INFLATORS

Standard Bore Inflating Gauge. Inflates And Checks Pressure Of Passenger Cars, Motorcycles And Trucks. Has 5 Foot Hose Length. Dual Calibrated 10 To 170 Psi In 2 Lbs. Increments And .7 To 12 Bar.

Code	Description
3910S	Schrader Standard Bore Inflating Gauge With 5ft hose



3910S

LARGE BORE GAUGES AND INFLATORS

Large Bore Precision Pressure Gauge 0 - 160 Psi. Recalibrateable By Means Of Set Screw - In The Face Of Dial. Features Pressure Retaining/Release Valve. Equipped With 16" Hose And Plastic Handle Push - On Chuck. Rubber Protective Cover. Shipped In Sturdy Plastic Case.

Code	Description
EX - 1800PH	Large Bore Precision Pressure Gauge



EX - 1800PH

Large Bore Precision Inflation Gauge 0 - 170 Psi. Features Bleeder Valve For Reducing Pressure, Rubber Protective Bumper And Sturdy Casing. Provides Accuracy, Quality And Longevity. Recalibratable At Factory. 6 Ft - 1/4" Hose With Euro Open Chuck.

Code	Description
EX - 980FT	Large Bore Precision Inflation Gauge



EX - 980FT

Large Bore Inflating Gauge For Large Bore Valves In OTR Tires. 10 To 120 Psi. Dual Foot Large Bore Angle Chuck. 15" Hose. Site Glass For Easy Reading. Allows Operator To Check Pressure And Inflate OTR Tires In One Tool. Quick And Easy.

Code	Description
08 - A1 - 506	Large Bore Inflation Gauge With 15" Hose

Large Bore Straight On Pencil Gauge Fits Large And Standard Bore Valves. 4 - Sided Nylon Bar, 2 Sides Calibrated 20 - 120Lbs. In 2Lbs. Units. Other 2 Sides 150 - 800 Kpa.

Code	Description
VHJ6111	Straight Large Bore - Standard Bore Gauge



VHJ6111

Large Bore Swivel Pressure Gauge. Nylon Indicator Bar. 20 - 120Psi.

Code	Description
EX - 1255	Swivel Large Bore Gauge Nylon Indicator Bar



8810 - H

Large Bore Swivel Pressure Gauge. Metal Indicator Bar. 10 - 150 Psi.

Code	Description
GA - 255S	Swivel Large Bore Gauge Metal Indicator Bar



EX - 1255

Large Bore Swivel Pressure Gauge. Metal Indicator Bar. 10 - 150 Psi. Recalibratable Version.

Code	Description
EX - 1255MC	Swivel Large Bore Gauge Metal Indicator Bar



GA - 255S



EX - 1255MC



INFLATION GAUGES

General Duty Inflating Gauges With Lightweight Aluminum Bodies And Brass Movements. 4 - Sided Bar With 2 Sides Calibrated 10 - 90Psi In 2Lbs. Units. Other 2 Sides Are In Kpa. Comes With Dual Foot Chuck On The End Of A 1 Foot Hose.

Code	Description
EX - 54 - 920 - 1	Inflating Gauge - 1 Foot hose



EX - 54 - 920 - 1

General Duty Inflating Gauges With Lightweight Aluminum Bodies And Brass Movements. 4 - Sided Bar With 2 Sides Calibrated 10 - 90Psi In 2Lbs. Units. Other 2 Sides Are In Kpa. Comes With Clip - On Chuck On The End Of A 1 Foot Hose.

Code	Description
EX - 54 - 920 - 3	Inflating Gauge - 3 Foot hose

General Duty Inflating Gauges With Lightweight Aluminum Bodies And Brass Movements. 4 - Sided Bar With 2 Sides Calibrated 10 - 90Psi In 2Lbs. Units. Other 2 Sides Are In Kpa. Comes With Clip - On Chuck On The End Of A 3 Foot Hose.

Code	Description
EX - 920	Inflating Gauge - 5 Foot hose



EX - 54 - 920 - 1

Large Bore Inflating Gauge Calibrated 10 - 150 Psi In 2Lbs. Increments. Comes With 5 Ft Hose And EX - 4660A Chuck

Code	Description
EX - 923	Inflator Gauge - Large Bore - 5 ft Hose
EX - 923 - 10	Inflator Gauge - Large Bore - 10 ft Hose
EX - 923 - 12	Inflator Gauge - Large Bore - 12 ft Hose
EX - 923 - 20	Inflator Gauge - Large Bore - 20 ft Hose
EX - 923 - 25	Inflator Gauge - Large Bore - 25 ft Hose



EX - 923



EX - 54 - 920 - 3

Exactra Inflator Gauge. Comes With Clip - On Chuck And A 5 Foot Hose. Calibrated 10 - 150 Psi In 2Lbs. Increments.

Code	Description
EX - 924	Standard Bore Inflating Gauge - 5 Foot
EX - 924 - 1	Standard Bore Inflating Gauge - 1 Foot
EX - 924 - 3	Standard Bore inflating Gauge - 3 Foot
EX - 924 - 6	Standard Bore inflating Gauge - 6 Foot
EX - 924 - 10	Standard Bore inflating Gauge - 10 Foot
EX - 924 - 12	Standard Bore inflating Gauge - 12 Foot
EX - 924 - 15	Standard Bore inflating Gauge - 15 Foot



EX - 924 - 6



EX - 924 - 1



MASTER GAUGES AND CHECK STATIONS

Master Service Gauge. Precision Instrument For Testing Accuracy Of Tire Gauges Calibrated 10 To 150Lbs. In 2Lbs. Units.

Code	Description
VH667	Master Service Gauge



VH667

For Checking Accuracy Of Service And Pencil Gauges. Features Retaining Valve To Hold Pressure Reading After Gauge Is Removed. Calibrated 0 - 160 Psi. Accurate To 2% Of Total Dial Range.

Code	Description
8860 - C	Master Dial Gauge



8860 - C

Gauge Check Station. Allows Checking Of Air Gauge Accuracy. Great For Truck Fleets. Made In USA . Consists Of 0 - 160 Liquid Filled Gauge. Certificate Of Accuracy Included. Mounts To Bench Or Wall. 1/4" N.P.T. Air Inlet. Includes Filters / Regulator.

Code	Description
8500	Gauge Check Station



8500

Digital Gauge Check Station. Allows Checking Of Air Gauge Accuracy. Great For Truck Fleets. Made In USA . Consists Of 0 - 200 Digital Gauge. Certificate Of Accuracy Included. Mounts To Bench Or Wall. 1/4" Npt Air Inlet. Includes Filters / Regulator.

Code	Description
8500 - D	Gauge Check Station - Digital



8500 - D

Air Gauge Checking Station. Rated 0 - 200 Psi. Includes Factory Calibration Document. Features Standard Bore Port, Large Bore Port And Female Coupler Port. Includes Regulator And Filters For Proper Filtration Mounts To Wall Or Bench. Accuracy +/- 1 Psi

Code	Description
476 - 35020	Air Gauge Checking Station



476 - 35020

Air/Liquid Gauge Checking Station. Rated 0 - 150 Psi. Includes Factory Calibration Document. Features Standard Bore Port, Large Bore Port And Female Coupler Port. Includes Regulator And Filters For Proper Filtration Mounts To Wall Or Bench. Accuracy +/- 1 Psi

Code	Description
476 - 35021	Air Liquid Gauge Checking Station

Replacement Air/Liquid Gauge For 476 - 35021 Gauge Checking Station. This Gauge Is Liquid Filled And Ranges From 0 - 200 Psi.

Code	Description
476 - 03521	Replacement Air Liquid Gauge



476 - 35021



INFLATION GAUGES

Truck Tire Inflator Gauge. Comes With A Dual Foot Locking Chuck And A 15 Foot Hose. Calibrated 10 - 160 Psi In 2Lbs. Units. Built - In Deflator Button To Relieve Excess Pressure. Site Glass With Magnifier Lens. Made In USA .

Code	Description
98 - A1 - 501	Truck inflating Gauge With 15 ft hose
516	Inflation Gauge With 15" hose



98 - A1 - 501

Inflator Gauge. Comes With An Clip - On Chuck And A 20 Foot Hose. Calibrated 10 - 120Psi In 2Lbs. Increments.

Code	Description
EX - 924 - 20	Standard Bore Inflating Gauge With 20 Foot hose



EX - 922

Small Bore Hd Inflator Gauge With Check Valve

Code	Description
EX - 922	Standard Bore Heavy Duty Inflator With psi Check Valve

General Duty Infating Gauge With Lightweight Aluminum Body And Brass Movements. 4 - Sided Bar With 2 Sides Calibrated 10 - 90Psi In 2Lbs. Units. Other 2 Sides Are In Kpa. Comes With Clip - On Chuck On The End Of A 6 Foot Hose.

Code	Description
EX - 54 - 920 - 6	Inflating Gauge With 6 Foot Hose



EX - 54 - 920 - 6

Mk3 Inflating Gauge With 6 Ft. Hose. Features A Cast Aluminum Body With An Impact Absorbing Rubber Bumber. Lightweight And Has A Magnified Sight Glass Done In Linear Scale. Excellent Acuracy 0 - 138 Psi Euro Chuck Connector.

Code	Description
ALG3A099	Mk3 Inflating Gauge With 6 ft. hose



ALG3A099

Inflator Chuck With Standard Bore Core Remover. The Body Is Made Of A Clear Acrilic Material Which Makes It Easier To See The Valve Core Being Extracted.

Code	Description
IN - 20	Inflator chuck With Standard Bore Core Remover



IN - 20



DUAL FOOT AIR CHUCKS

Dual Foot Angle Air Chuck. Closed End For Use On Air Lines. For Inner Dual Wheel Hard - To - Reach Valves On Tractor, Dual Wheel Truck And Bus Tires. Also Fits Passenger Tires. Pushes Or Pulls On Tire Valve. Length 6" (152 mm) With 1/4" Female N.P.T.



A - 696

Code **Description**

- VH696** Dual Foot Chuck - Closed
- A - 696** Dual Foot Chuck - Closed
- 2 - 261** Dual Foot Chuck - Closed

Dual Foot Straight On And 30° Reverse Angle Lock On Air Chuck. Closed End For Use On Air Lines. For Inner Dual Wheel Hard - To - Reach Valves On Tractor, Dual Wheel Truck And Bus Tires. Pushes Or Pulls On Tire Valve. Length 6" (152 mm) With 1/4" Female N.P.T.



A - 698

Code **Description**

- VH698** Dual Foot Chuck - Lock - On - 30° - Closed
- A - 698** Dual Foot Straight Chuck - Closed
- 2 - 263** Dual Foot Chuck - Lock - On - 30° - Closed
- VHP698** Dual Foot Chuck - Lock - On - 30° - Closed

A Special Air Chuck With A Straight - On Connection And A 180° Reverse Angle As Well. This Allows Easier Access To Valves Located In Tight, Hard To Reach Places. 6" Long



6175

Code **Description**

- 6175** Dual Foot Chuck - Lock - On - 30° - Closed

A Special Air Chuck With A Straight - On Connection And A 180° Reverse Angle As Well. This Allows Easier Access To Valves Located In Tight, Hard To Reach Places. 6" Long



CH - 370 - LO

Code **Description**

- CH - 370 - LO** Air chuck - 180° Reverse - Lock

Dual Foot Straight Chuck With A 30° Reverse End. This Unit Is 14" Long For Inflating Inner Duals And Has Locking Threads For Convenience.



VH698L

Code **Description**

- VH698L** Dual Foot Extra Long Straight Lock Chuck

Dual Foot Straight On And 30° Reverse Angle Lock On Air Chuck. Closed End For Use On Air Lines. For Inner Dual Wheel Hard - To - Reach Valves On Tractor, Dual Wheel Truck And Bus Tires. Pushes Or Pulls On Tire Valve. Length 14" (152 mm) With 1/4" Female N.P.T.



VHP698L

Code **Description**

- VHP698L** Dual Foot Long Chuck - Lock - On - 30° - Closed



SPECIALTY CHUCKS

Easy Lock Air Chuck 12" Reverse 180°. Easy On/Off Application. Custom Coupler Lock With Slide Release. Automatic Locking Design Chuck. Durable Hardened Steel Pins. USA Made

Code **Description**

- ES - 300** Easy Lock Air Chuck - Closed 12"
- ES - 301** Easy Lock Air Chuck - Open 12"



ES - 301

Easy Lock Air Chuck 12" Straight. Easy On/Off Application. Custom Coupler Lock With Slide Release. Automatic Locking Design Chuck. Durable Hardened Steel Pins.

Code **Description**

- ES - 305** Easy Lock Air Chuck - Closed 12"
- ES - 306** Easy Lock Air Chuck - Closed 12"



ES - 305

Dual Foot Angle Chuck. Open End For Use On Air Line Gauges. For Inner Dual Wheel Hard - To - Reach Valves On Tractor, Dual Wheel Truck And Bus Tires. Pushes Or Pulls On Tire Valve. Length 6" (152 mm) With 1/4" Female N.P.T.

Code **Description**

- 17 - 724** Dual Foot Chuck - Open



17 - 724

Dual Head Chuck - Free Flowing. This Is The Chuck End Only And Is Meant For Use With Inflator Gauges.

Code **Description**

- 500 - 4** Dual Head Chuck - Free Flowing



500 - 4

Tube Only For Dual Head Chuck. This Shaft Threads Into The Milton 500 - 4 Dual Head Chuck.

Code **Description**

- P500 - 5** Tube Only For Dual Head Chuck



P500 - 5

Right Angle Air Chuck Accepts Large Bore And Standard Bore Valves. Has Has 1/4" Female N.P.T. .

Code **Description**

- VHJ6100** RT Angle Chuck - Large Bore and Standard Bore



VHJ6100

AIR CHUCK REPLACEMENT

Replacement Washer - Designed For Haltec CH - 360 Series. Also Will Fit VH696 And VH698 Chucks.

Code **Description**

- 10140** Replacement Washer - CH - 360/VH696/VH698



10140

Repair Kit For CH - 360

Code **Description**

- CH - 360 - RK** Repair Kit For CH - 360



AIR CHUCK REPLACEMENT

Dual Foot Chuck Repair Kit For VH696 Contains 2 Rubber Washers, 2 Deflator Pins And 2 Nuts

Code **Description**

VH696RK Repair Kit For VH696

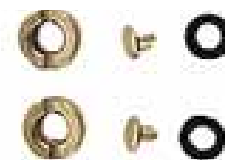

VH696RK

Dual Foot Chuck Repair Kit For VH698 Contains 2 Rubber Washers, 2 Deflator Pins And 2 Nuts

Code **Description**

VH698RK Repair Kit For VH698



VH698RK

Taper Lock - On Chuck Repair Kit For VHP698. Contains 2 Rubber Washers, 1 Tapered Locking Nut, 1 Standard Locking Nut And 2 Deflator Pins

Code **Description**

VHP698RK Tapered Lock On Repair Kit



VHP698RK

This Is The Repair Kit For Both The Exactra EX - 666 Long Large Bore Lock On Chuck And The Exactra Short Lock - On Chuck EX - 366.

Code **Description**

EX - 666K Repair Kit For EX - 666 And EX - 366

Repair Kit For CH - 360 - OP

Code **Description**

CH - 360 - OP - RK Repair Kit For CH - 360 - OP



377

LARGE BORE CHUCKS

Large Bore Long Lock - On Air Chuck. Chuck Locks On Valve Threads. Has 1/4" Female N.P.T.

Code **Description**

377 Large Bore Chuck Long - Lock - On



EX - 666

Large Bore Long Lock - On Air Chuck. Chuck Locks On Valve Threads. Has 1/4" Female N.P.T.

Code **Description**

EX - 666 Large Bore Chuck Long - Lock - On

Special Large Bore Bead Seating Chuck

Code **Description**

EX - 565 Special Large Bore Bead Seating Chuck



EX - 565

Large Bore Short Lock - On Air Chuck. Chuck Locks On Valve Threads. Has 1/4" Female N.P.T.

Code **Description**

EX - 366 Large Bore Chuck Short - Lock - On



EX - 366



SLIDING SLEEVE AIR CHUCKS

Open Check Lock - On Air Chuck Securely Locks Onto Valve When Pushed Forward. Released When Sleeve Is Pulled Back. For Use On Air Line Gauges. Has 1/4" Female N.P.T.

Code	Description
VH694	Open Check Chuck



VH694

Open Check Lock - On Air Chuck Securely Locks Onto Valve When Pushed Forward. Released When Sleeve Is Pulled Back. For Use On Air Line Gauges. Has 1/4" Female N.P.T.

Code	Description
A - 694	Open Check Chuck



A - 694

Closed Check Lock - On Air Chuck Securely Locks Onto Valve When Pushed Forward. Released When Sleeve Is Pulled Back. Has 1/4" Female N.P.T.

Code	Description
A - 695	Closed Check Chuck



A - 695

Closed Check Lock - On Air Chuck Securely Locks Onto Valve When Pushed Forward. Released When Sleeve Is Pulled Back. Has 1/4" Female N.P.T.

Code	Description
VH695	Closed Check Chuck



VH695

Specially Designed Air Chuck That Locks Onto Cap Threads Of Standard Bore Valves When Sliding Sleeve Is Pushed In The Forward Direction. Releases When Sleeve Is Pulled Back.

Code	Description
H - 5265	Sliding Sleeve Chuck - Closed



H - 5265

Grip Tite Chuck - Closed. This Is The Replacement To The Old Obsolete Schrader 5265 Chuck. 1/4" Female N.P.T. . Works Like A Quick Coupler. Snaps Onto Standard Tire Vavles And Stays Tight Until Released.

Code	Description
17 - 373	Grip Tite Chuck - Closed



17 - 373

BALL FOOT CHUCKS

Ball Foot Chuck. 1/4" Female N.P.T. Closed

Code	Description
VH690	Ball Foot Chuck - 1/4" Female - N.P.T. Closed



VH690



BALL FOOT CHUCKS

Ball Foot Chuck And Clip - Closed. This 1/4" Female N.P.T. Unit Firmly Locks Onto Valve While Inflating The Tire.

Code Description

- VH691** Ball Foot Chucks And Clips - 1/4" Female Closed
- A - 691** Ball Foot Chucks And Clips - 1/4" Female Closed



VH691

Ball Foot Chuck And Clip - Closed. This 1/4" Female N.P.T. Unit Firmly Locks Onto Valve While Inflating The Tire.

Code Description

- 6293 - DILL** Ball Foot Chucks And Clips - 1/4" Female Closed



6293 - DILL

Ball Foot Chuck And Clip - Closed. This 1/4" Female N.P.T. Unit Firmly Locks Onto Valve While Inflating The Tire.

Code Description

- VH692** Ball Foot Chucks And Clips - 1/4" Female Open



VH692

Ball Foot Chuck And Clip - Open. This 1/4" Female N.P.T. Unit Firmly Locks Onto Valve While Inflating The Tire.

Code Description

- 6293 - B** Ball Foot Chucks And Clips - 1/4" Female Open



6293 - B

Ball Foot Chuck Clip Only. This Unit Allows You To Replace The Clip Only On A Ball Foot Chuck Instead Of Relacing The Whole Unit.

Code Description

- VH693** Ball Foot Chuck Clip
- 6293 - A** Ball Foot Chuck Clip



VH693



6293 - A

BALL FOOT CHUCK REPLACEMENT

Rubber Washer For The VH690 Ball Foot Chucks.

Code Description

- VH690W** Ball Foot Washer



VH690W

Kit Includes A Rubber Washer, Deflator Pin And A Brass Nut To Refurbish Your VH690 Ball Foot Chuck. These Are All The Wear Parts.

Code Description

- VH690RK** Ball Foot Repair Kit



VH690RK



EURO STYLE CHUCK

Euro Style Chuck And Clip - Closed. This 1/4" Female N.P.T. Unit Firmly Locks Onto Valve While Inflating The Tire.

Code	Description
CH - 360	Closed Euro Clip - On Chuck
A - 686	Closed Euro Clip - On Chuck



CH - 360

Euro Style Chuck And Clip - Closed. Has 1/4" N.P.T. Female End.

Code	Description
6293 - D	Closed Euro Clip - On Chuck 1/4" Female



A - 686

Euro Style Chuck And Clip - Open. This 1/4" Female N.P.T. Unit Firmly Locks Onto Valve While Inflating The Tire.

Code	Description
CH - 360 - OP	Open Euro Clip - On Chuck



6293 - D

Euro Style Chuck And Clip - Open. This 1/4" Female N.P.T. Unit Firmly Locks Onto Valve While Inflating The Tire.

Code	Description
A - 687	Open Euro Chuck - 1/4" Female



CH - 360 - OP

Euro Style Chuck And Clip - Closed. This 1/4" Hose Barb Unit Firmly Locks Onto Valve While Inflating The Tire.

Code	Description
A - 689	Closed Euro Chuck - 1/4" Male
EX - 1587C	Close Euro Clip - On 1/4" Barbed
CO8H72	Open Euro Clip - On Chuck and Barb



A - 689

Open End Barbed Style Euro Air Chuck - Serrated Shank for 1/4" I.D. Hose

Code	Description
EC410419	Open Barbed Euro Air chuck



EC410419

Euro Style Chuck And Clip - Open. This 1/4" Hose Barb Unit Firmly Locks Onto Valve While Inflating The Tire.

Code	Description
A - 688	Open Euro Chuck - 1/4" Male
EX - 1587	Open Euro Chuck - 1/4" Male
6293 - C	Open Euro Clip - On Chuck and Barbed



EX - 1587

Euro Style Chuck And Clip - Open. This 1/4" Hose Barb Unit Firmly Locks Onto Valve While Inflating The Tire. For Tire Changer Gauges.

Code	Description
1137 - 6	Euro Style Chuck - Open - 1/4"
N - 1200	Euro Style Chuck - Open - 1/4"
N - 1199	Euro Style Chuck - Open - 3/16"



A - 688



INTERCHANGE COUPLER

Triple Interchange Coupler Will Accept 1/4" Industraightial Interchange Nipples, 1/4" Aro - Type Nipples And 1/4" Tru - Flate Type Nipples. Will Not Accept 1/4" Lincoln - Type Nipples.

Code	Description
VHC50	Triple Interchange Coupler



VHC50

AUTOMATIC INFLATION SYSTEMS

The CHR - 1 Cheetah Inflation System Is Built For Heavy Shop Use And Years Of Service. It Is Compact And Lightweight. It Safely And Accurately Inflates Up To Four Tires At One Time. Includes 4 - 10 Ft. Inflation Hoses.

Code	Description
CHR - 1	Cheetah Inflation System



CHR - 1

PCL Acura Qube Tire Inflator With 16' Hose And Euro Chuck. 3 Pre - Select Application Modes: Highly Accurate. Max Inflation 145 Psi. Increments 1Psi Just Preset 2Psi, Connect Chuck And Auto Start Does The Rest.

Code	Description
QUBE4	Acura Qube Tire Inflation With 16 Foot Hose



QUBE4

Haltec Hi - Volume Tire Inflator. Utilizes 1/2" Inlet Hose To Quickly And Acuratly Inflate 1 To 4 Tires. Approximately 4 Minutes To Go From 6 To 100 Psi. Includes The 89 - 3W1/2" Replacement Air Flow Control Valve As A Standard Accessory.

Code	Description
89XDB	Haltec High Volume Tire Inflator



89XDB

AME Hi - Volume Tire Inflator. Utilizes 1/2" Inlet Hose To Quickly And Acuratly Inflate 1 To 4 Tires. Allows Technician To Move Away From Tires During Inflation.

Code	Description
AME - 24100	AME High Volume Tire Inflator

4 Tire Auto Inflator. Maximum 150 Psi. Reliable And Sturdy. Can Be Mounted To Wall Or Tire Cage With Use Of MW - Stand Bracket. Simple Installation. 110V With 1/4" Air Inlet. Inflates 4 Tires From 0 - 150 Psi In 2 Psi Increments. Dimensions 9" X 10 - 1/2" X 3 - 1/2". 4 - 8Ft Hoses

Code	Description
MW - 40	4 - Tire Auto Inflate - Max 150psi



MW - 40

Cage Bracket For Inflators. Allows The MW - 60, MW - 40, MW - 64HP Auto Tire Inflators To Be Mounted To The MIC - 3, MIC - 4, MIC - 5 And MIC - OTR Tire Stands. Dimensions 10 - 11/16" X 4" X 8 - 15/16" With Hanger Hook For Air Hose.

Code	Description
MW - STAND	Cage Bracket For Inflators



MW - STAND



CHECK OUT OUR WEBSITE!

www.premacanada.ca

TIRE INFLATION SAFETY CAGES

Portable 2 Bar Safety Cage. Compact And Lightweight. Meets Or Exceeds OSHA Standard 29 CFR 1910.177. Dimensions 17" X 2" X 52".

Code Description

MIC - 2 Portable 2 Bar Safety Cage



MIC - 2

Truck - 3 Bar Safety Cage. Holds Up To 54" Diameter And 20" Wide. Meets Or Exceeds OSHA Standard 29 CFR 1910.177. Dimensions 22" X 26" X 57".

Code Description

MIC - 3 Truck - 3 Bar Safety Cage



IIC - 3

Truck - 4 Bar Safety Cage. Holds Up To 54" Diameter And 20" Wide. Meets Or Exceeds OSHA Standard 29 CFR 1910.177. Dimensions 32" X 26In X 57"

Code Description

MIC - 4 Truck - 4 Bar Safety Cage



MIC - 4



MIC - 5

Truck - 5 Bar Safety Cage. Holds Up To 54" Diameter And 20" Wide. Meets Or Exceeds OSHA Standard 29 CFR 1910.177. Dimensions 41" X 26" X 57".

Code Description

MIC - 5 Truck - 5 Bar Safety Cage



TIRE INFLATION SAFETY CAGES

Passenger 3 Bar Safety Cage. Specs 19.5" X 21.75" X 37".

Code Description

2130 Passenger - 3 Bar Safety Cage



2130

Truck - 6 Bar Safety Cage. Heavy Duty inflation Cage. Made Of 2 - 1/4" Diameter Hi Tensile Steel Tubing. Handles Tires Through 14:00 X 24, 54" Diameter

Code Description

2260 Truck - 6 Bar Safety Cage



2260

2 Bar Portable Safety Cage. Height - 43 - 1/2" (110.5 Cm.) Width - 16" (40.6 Cm.) Base - 6" X 21 - 1/2"

Code Description

T101 Portable 2 Bar Safety Cage

2 Bar Portable Wide Base Safety Cage. 43 - 1/2" High X 20 - 1/2" Wide. The Base Is 7" Closed X 27". Will Hold Super Singles And Super Wide Radial Tires.

Code Description

T101A Portable Wide Base Cage 2 Bar



T101A

2 Bar Super Single Tire Cage. Inside Dimensions Are 49 - 1/16" High X 22" Wide. The Tubing Is 44W Steel And The Unit Is Powder Coated Orange. It Does Collapse For Convenient Storage.

Code Description

MIC - 2WB 2 Bar Super Single Tire Cage



T102

4 Bar Safety Cage. Height - 43 - 1/2" (110.5 Cm.) Width - 20 - 1/2" (52.1 Cm.) Base - 31 - 1/2" X 26" (80 Cm X 66Cm)

Code Description

T102 Truck - 4 Bar Cage



MIC - OTR

3 Bar OTR Cage. The Inner Height Is 65" And The Inner Width Is 24". The Steel Base Is 30" X 27".

Code Description

T104 OTR - 3 Bar Cage

5 Bar OTR Cage. The Inner Height Is 64 - 5/8" And The Inner Width Is 33 - 5/8". The Steel Base Is 39 - 3/8" X 41".

Code Description

MIC - OTR OTR - 5 Bar Safety Cage

Rollers For Tire Inflation Cage. Built With Steel And Finished In Powder Coated Paint. Equipped With 2 Sturdy Steel Rollers That Can Handle 1 Up To 450 Lbs. Allows Easy Positioning Of Tire Valve For Air Line Connection. Dimensions 15" X 15" X 2".

Code Description

MIC - ROLLER Rollers for Tire Inflator Cage



MIC - ROLLER

AUTOMOTIVE EQUIPMENT SERVICE ACCESSORIES AT YOUR FINGERTIPS

TMR
The Main Resource

Automotive Professional Products





Shop Equipment Accessories And Parts





TIRE CHANGER ACCESSORIES AND PARTS

Lubricant Bucket For Tire Changers - Straight/Red.

Code	Description
LB106259	Red Lubricant Bucket For Tire Changers



LB106259

Lubricant Bucket For Tire Changers - Straight - Black.

Code	Description
LB66006	Black Lubricant Bucket For Tire Changers

Lubricant Bucket For Tire Changers - Angled.

Code	Description
LB106572	Angled Lubricant Bucket For Tire Changers

Replacement Gauge Clear Protective Cover. This Unit Includes A New Gasket And Threads Right Into The Original Gauge.

Code	Description
COA107517	Replacement Air Gauge Glass



COA107517

The Wonder Bar Mag Wheel Tool. Will Not Damage Aluminum Or Mag Wheels. Works With All Centre Post Changers. Polymer Inserts Securely Attach To Tool And Outlast Standard Booties.

Code	Description
AME - 72000	The Wonder Bar Mag Wheel Tool



LC107517

Air Gauge For Coats Tire Changers Flange Mount. This Unit Works With The 4000, 5000 And 7000 Series.

Code	Description
AG107985	Coats Air Gauge



AG107985

Air Gauge For FMC/John Bean Tire Changers.

Code	Description
AG66170	Tire Changer Air Gauge



AG66170

Snap - On Bead Breaker Blade Cover. This Is A Nylon Bead Breaker Cover That Works On Many FMC, Snap - On And John Bean Tire Changers.

Code	Description
TCB7900	Snap - On Bead Breaker Blade Cover



TCB7900

Air Inflation Hose With Chuck At One End And 1/8" Male N.P.T. At Other End That Goes With All Upright Rim Clamp Type Hofmann Tire Changers.

Code	Description
HB - 2408318	Hofmann Tire Changer Inflation Hose With Fittings



HB - 2408318



TIRE CHANGER ACCESSORIES AND PARTS

Inflator Hose Assembly With Open End Barbed Style Euro Chuck - 60" Long

Code	Description
HA714100	Inflator Hose Assembly



HA714100

Inflator Hose Assembly With Open End Barbed Style Euro Chuck - 60" Long 1/8" Male N.P.T.

Code	Description
HA2408318	Inflator Hose Assembly



HA2408318

Coats Hold Down Cone For All Coats Post Style Tire Changers.

Code	Description
COA108276	Coats Hold Down Cone



COA108276

Coats Type Hold Down Cone. Coats OEM Code 8108276 (8000433). Works On Coats Older Post Style Tire Changers Like 4040, 4040SA And 4050.

Code	Description
TC108276	Coats Type Hold Down Cone



TC108276

Inflator Hose Assembly With Open End Barbed Style Euro Chuck - 60" Long. All Brass Connectors - 1/4" I.D. - 19 BSP

Code	Description
HA106871	Inflator Hose Assembly



HA106871

Inflator Hose Assembly With Open End Female Style Euro Chuck - 60" Long. Male Brass Connectors - 1/4" I.D. - 19 BSP

Code	Description
HA137 - 86 - 2	Inflator Hose Assembly



HA137 - 86 - 2

Inflator Hose Assembly With Open End Barbed Style Euro Chuck - 52" Long. All Brass Connectors - 1/4" I.D. - 19 BSP

Code	Description
HA67715	Inflator Hose Assembly

Snap - On Bead Breaker Blade Edge Cover

Code	Description
EAA0304G15A	Snap - On Bead Breaker Blade Edge Cover



EAA0304G15A

Coats 5060 - Table Top Seal Kit

Code	Description
COA183811	Coats 5060 - Table Top Seal Kit



TIRE CHANGER ACCESSORIES AND PARTS

Coats Bead Breaker Blade Edge Cover - 2 Pack.

Code	Description
COA183606	Bead Breaker Edge Blade Cover - 2 Pack



COA183606

Bead Breaker Cylinder Seal Kit. For Earlier And Late Model Tire Changers.

Code	Description
TI115	Bead Breaker Cylinder Seal Kit



TI115

Table Top Cylinder Seal Kit.

Code	Description
TI181162	Table Top Cylinder Seal Kit



TI181162

Bead Breaker Cylinder Seal Kit

Code	Description
TI182079	Bead Breaker Cylinder Seal Kit



TI182079

Large Pad Kit For Coats Changers. Kit Includes 2 - TI181851 And 1 - TI181855.

Code	Description
TI851855	Large Pad Kit For Coats Changers - Kit Includes 2 - TI181851 and 1 - TI181855



TI851855

Reversing On/Off Single Phase Switch Assembly. 40 Amp. Will Work With Accuturn, FMC, John Bean, Snap - On And Hofmann Tire Changers. Any Changer Made By GS Boxer.

Code	Description
SW20016433	Reversing On/Off Switch Assembly



SW20016433

Coats Forward - Reverse Switch 25 Amp. Compatible With Coats 5000 Series, 6000 Series And 7000 Series Tire Changers.

Code	Description
SW184389	Coats Forward - Reverse Switch 25 Amp



SW184389

Centre Rubber Pad For Coats Tire Changers.

Code	Description
TI181065	Centre Pad For Coats Changers



TI181065

Large Centre Rubber Pad For Coats Tire Changers.

Code	Description
TI181855	Large Centre Pad For Coats Charger



TI181855



TIRE CHANGER ACCESSORIES AND PARTS

Large Bead Loosener Nylon Front Pad For Coats Tire Changers.

Code	Description
TI181851	Large Bead Loosener Pad - Coats



TI181851

Small Bead Loosener Nylon Front Pad For Coats Tire Changers.

Code	Description
TI181173	Small Bead Loosener Pad - Coats



TI181173

Coats Part - Shim Kit.

Code	Description
COA182339	Coats Tire Changer Part - Shim Kit

Coats 5060EX - 4 - Way Valve With Pull Pin.

Code	Description
TC181995	Coats 5060EX - 4 - Way Valve With Pin



TC181995

Coats 7060 - 27". Nylon Hose.

Code	Description
COA183680	Coats 7060 - 27" Nylon Hose

Coats Part - Drop Centre Tool.

Code	Description
COA184052	Coats Part - Drop Centre Tool

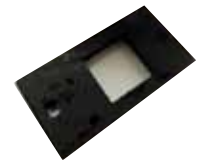

COA181788

Coats 5060 - Lock Plate.

Code	Description
COA181788	Coats 5060 - Lock Plate

Nylon Mount/Demount Duckhead Assembly. This Is The Complete Assembly.

Code	Description
TC14024784	Nylon Mount/Demount Duckhead Assembly



TC14024784

Nylon Mount/Demount Duckhead Only. Does Not Include The Mounting Hardware.

Code	Description
TC20024335	Nylon Mount/Demount Duckhead Only



WHEEL BALANCER ACCESSORIES

Code	Description
COA308820	Coats Spring For Back Cone Balancing
COA110542	Coats 850/950 - Pressure Cup
COA112568	Coats 1050/1250 - Air Nut 40 mm x 8.46 mm
HN110543	Coats Type Manual Hub Nut 28.5 mm
WB110542	Coats Type Pressure Cup - 28.5 mm
WB144026	Coats Type Hub Nut With Cup 28.5 mm



Corgi Polymer Passenger Cone Cover. This Cover Is Used On The Corgi AM26 Artiglio Tire Changer.

Code	Description
444 - 61668	Corgi Poly Passenger Cone Cover
444 - 43232	Corgi Polymer Truck Cone Cover



Rubber Rings And Pressure Cups For Hunter Pressure Cup.

Code	Description
WB106822	4.5" Rubber Ring For Hunter Pressure Cup
WB1753531	4.5" Pressure Cup - Hunter Quick Nut
WB1753921	6" Pressure Cup - Hunter Quick Nut
WB1061572	6" Rubber Ring - Hunter PressureCup
WB463202	Spacer For Hunter Quick Release Nut



Code	Description
HN61072	FMC Type Manual Hub Nut 40 mm
WB112373	FMC Extended Threaded Shaft 40 mm
WB308171	Coarse Thread Shaft - 28.5 mm



Code	Description
WB - 310000	Caliper For Wheel Balancer - Plastic
AME - 51550	Rim Bolt Circle Gauge
AME - 69250	Multi - Pack Colour Wheel Gauge

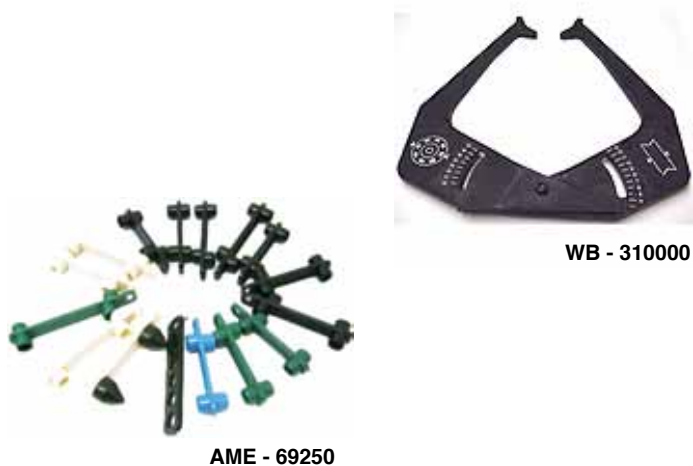



MANUAL TIRE CHANGERS

Handles Rims 4" To 16.5" Adjustable And Durable. Includes The CV - 4 Mongoose Tool Which, In Combination With The CH - 22, Makes Changing Small Tires An Easier Task. Comes With One Set Of CH2 - JP - Set Jaw Protectors (3 - Pack).

Code	Description
CH22	Manual Tire Changer - Rims 4" To 16.5"



CH22

This Is The Stand For The CH22 Tire Changer. Note The Stand Includes A Bead Breaker That Is Built Into The Side Of The Unit. The Changer Bolts Into The Top And The Stand Can Be Lagged Into The Floor If Desirable.

Code	Description
CH23	Manual Tire Changer Stand



CH4

Mongoose Tire Tool. This Is Used With The CH22 / CH23 Small Wheel Tire Changing System. When You Purchase A CH22 The CH4 Mongoose Tool Is Included

Code	Description
CH4	Mongoose Tire Tool

CH22 Part - Threaded Rod Assembly

Code	Description
CH22 - 41002	CH22 Part - Threaded Rod Assembly



CH4

CH22 Jaw Protector 3 - Pack

Code	Description
CH22 - JP - SET	TSI CH22 Jaw Protector 3 - Pack



CH22 - 41002

CH22 Part - Jaw Frame Adjusting Weldment.

Code	Description
CH22 - 10065	CH22 Part - Jaw Frame Adjustment Part



CH22 - JP - SET

TIRE CHANGER ACCESSORIES AND PARTS

MX Tire Mounting Clamp. Designed For Low Profile Tires. Holds The Tire Bead Below The Rim Flange For Fast, Damage-Free Tire Mounting. Impact Resistant Plastic Will Not Damage Custom Wheels.

Code	Description
AME - 72100	MX Tire Mounting Clamp



AME - 72100

Bead Depressor Drop Centre Tool

Code	Description
TC435685	Bead Depressor Drop Centre Tool



TC435685



TIRE CHANGER ACCESSORIES AND PARTS

Nylon Mount/Demount Duckhead Kit.

Code	Description
TC250309	Nylon Mount/Demount Duckhead Kit



TC250309

Nylon Mount/Demount Duckhead Only.

Code	Description
TC450310	Nylon Mount/Demount Duckhead Only



TC450310

Red Nylon Mount/Demount Duckhead 1 Pack. Can Fit Many Hunter Tire Changers.

Code	Description
TCR343	Red Nylon Mount/Demount Duckhead - 1 Pack



TC0343 - 6

Red Nylon Mount/Demount Duckhead 6 Pack

Code	Description
TCR343 - 6	Red Nylon Mount/Demount Duckhead - 6 Pack



TCR343

Steel Mount/Demount Head - Coats Tapered. For Coats Tire Changers With Tapered Shaft.

Code	Description
TC182788	Steel Mount/Demount Head - Coats Tapered



TC182788

Steel Mount/Demount Head - Coats Round. For Coats Tire Changers With Round Shaft.

Code	Description
TC183429	Steel Mount/Demount Head - Coats Round



TC183429

Nylon Mount / Demount Duckhead. 6 Pack.

Code	Description
TC0343 - 6	Nylon Mount/Demount Duckhead - 6 Pack

Adjustable Rim Clamp Jaw - Coats 5060 Ordered Individually

Code	Description
COA182247	Adjustable Rim Clamp Jaw - Coats 5060

Coats 7060 - 3 Position Jaw 4 - Set. This Rim Clamp Jaw Has 3 Holes That Allow Re - Positioning For Many Co mmon Rim Sizes.

Code	Description
COA184926	Coats 7060 - 3 Position Jaw - 4 - Set



TIRE CHANGER ACCESSORIES AND PARTS

Coats Type Jaw Extension 4 Pack. These External Jaws Clamp Wheels Up To And Including 16" To 28" Works Well On Coats 50 Series, 60 Series And 70 Series Tire Changers.

Code	Description
TC184958 - 4	Coats Type Jaw Extension 16 - 28" - 4 Pack



TC184958 - 4

Coats Type 3 - Position Extension Clamp Kit For Coats Models With Adjustable Carriers. External (Outside / In) Wheel Clamping 6" - 22" This Kit Includes The 4 Position Push Buttons (182250). Works On Coats 50 Series, 60 Series And 70 Series.

Code	Description
TC113125C	Coats Type 3 - Position Extension Clamp Kit



TC113125C

Position Push Buttons. These Are Spring - Loaded

Code	Description
TC182250	Position Push Buttons



TC182250

Coats Type 3 - Position Extension Clamp 4 Pack. For Coats Models With Adjustable Carriers. External (Outside / In) Wheel Clamping 6" - 22" Works On Coats 50 Series, 60 Series And 70 Series Rim Clamp Tire Changers.

Code	Description
TC184126 - 4	Coats Type 3 - Position Extension Clamp - 4 Pack

Coats Replacement Rim Clamp Jaw. For Coats RC1, 5, 10, 15 And 20. This Is a 4 Pack.

Code	Description
TC181677 - 4	Coats Replacement Rim Clamp Jaw - 4 Pack



TC184126 - 4

Coats Type X - Out Clamp Kit. For Clamping 13" To 24" Alloy Wheels. This Kit Includes The 4 Position Push Buttons (182250), X - Out Clamps (184268), Quilted Clamp Socks (183604). For Coats 50,60,70 Series.

Code	Description
TC184327	Coats Type X - Out Clamp Kit - 4 Pack

Coats Type X - Out Jaw - 1 Piece. Individual Jaw From The TC184327 Kit.

Code	Description
TC184268	Coats Type X - Outjaw - 1 Piece.



TC336742 - 4

Coats RC15AA - Jaw Clamp.

Code	Description
TC336742 - 4	Coats RC15AA - Jaw Clamp

Monty 1510 - Clamping Jaw. Ordered Individually.

Code	Description
HB - 3008225	Monty 1510 - Clamping Jaw



HB - 3008225



TIRE CHANGER ACCESSORIES AND PARTS

Coats Adjustable Rim Clamp Jaws - 4 Pack. Adjustable 2-Button Type.

Code	Description
TC182247 - 4	Coats Adjustable Rim Clamp Jaws - 4 Pack



TC182247 - 4

RC150 Part - Steel Mount/Demount Head

Code	Description
COA183355	RC150 Part - Steel Mount/Demount Head



COA183604

Coats 5050E Jaw Covers. Set Of 10. For Use On Coats Rim Clamp Tire Changers.

Code	Description
COA183604	Coats Jaw Covers - 10 Pack



HB - 4024181

Insert For Mount/Demount Head.

Code	Description
HB - 4024181	Hofmann - 1620 - Insert Mount/Demount Head - 10 Pack

Accu Type Mount/Demount Head Insert - 4 Pack.

Code	Description
Ti24016079	Accuturn Type Mount/Demount Head Insert - 4 Pack



ACCU - SM101608

Accuturn Mount/Demount Head Insert - 5 Pack. This Will Also Work On Sicam And Bosch Mount Demount Heads. 5 Pack

Code	Description
ACCU - SM101608	Accuturn - Mount/Demount Head Insert - 5 Pack

Coats 9010/9024 Jaw Cover 6/Pk

Code	Description
COA9209612	Coats 9010/9024 Jaw Cover 6 Pack



COA9209612

Accuturn Mount/Demount Head Insert - 10 Pack. This Does Not Come With A Replacement Pin.

Code	Description
Ti20011064 - 10	Accuturn Mount/Demount Head Insert - 10 Pack



Ti20011064 - 10

Roll Pin For Accuturn Inserts Under Either Part Number Ti24016079 Or Ti20011064 - 10.

Code	Description
RP27040080	Roll Pin For Accuturn Inserts



TIRE CHANGER ACCESSORIES AND PARTS

Insert - Coats Type Mount/Demount Head 2 Pack Fits The Mount/Demount Heads On Coats Tire Changers RC1, RC5, RC15, 5030, 5040, 5050, 5065, 5070, 6050, 6060, 6065, 7050, 7055, 7060, 7065, 7655, 7660 And 7665.

Code	Description
TI182961	Insert - Coats Type Mount/Demount Head - 2 Pack



TI254341A

Code	Description
TI254341A	Coats Type 9010/24 Mount/Demount Insert - 10 Pack



TI182961

For Hofmann Mount/Demount Head - On Rim Clamp Changers.

Code	Description
HB - 3317259	Hofmann Plastic Head Insert



HB - 3317259

For Hofmann Mount/Demount Head - On Rim Clamp Changers.

Code	Description
HB - 3310678	Hofmann Plastic Head Insert



HB - 3310678

Hofmann 1620 Mount/Demount Head Nylon Insert - New Style.

Code	Description
EAC0078G50A	Hofmann 1620 Mount/Demount Nylon Insert - New Style



EAC0078G50A

Corghi Jaw Protectors 1 Pack. Will Work With Models Like The A9820 Toni.

Code	Description
8 - 11100108	Corghi Jaw Protectors - 1 Pack



EAC0078G50A

This Is The Protective Insert That Goes Into The Mount / Demount Head Of An FMC 8800 Tire Changer. Also Works On FMC8600 Mount/Demount Head.

Code	Description
FMC87084	FMC 8800 Mount/Demount Head Insert

John Bean EHP System 4 - Nylon Long Arm Inserts For Steel Mount/Demount Head 10 Pack - Black. These Long Arm Inserts Will Also Work On Many Snap - On, FMC And Even Some GS Boxer Tire Changers.

Code	Description
TC247G15A - 10	Coats 9010/9024 - Nylon Mount/Demount Head



TC247G15A - 10



TIRE CHANGER ACCESSORIES AND PARTS

Plastic Insert Snap - On Clamps 10 Pack

Code	Description
TCB7591 - 10	Plastic Insert Snap - On Clamps - 10 Pack



TCB7591 - 10

Rim Clamp Motorcycle Changer Protectors 12 Pack. A Specially Designed Bootie For The Coats Motorcycle Mount/Demount Duckhead.

Code	Description
COA183374	Rim Clam Motorcycle Changer Protectors - 12 Pack



COA183374

Coats 7600 - White Nylon Jaw Inserts - 8 - Pack. Two White Nylon Jaw Inserts Required Per Jaw.

Code	Description
COA059408	7600 - White Nylon Jaw Insert - 8 Pack



TCB304 - 4

Snap - On Jaw Clamp Covers 4 Pack. These Jaw Covers May Also Work On John Bean And Older FMC Models.

Code	Description
TCB304 - 4	Snap - On Jaw Clamp Covers - 4 Pack



HB - 3309048

Nylon Jaw Cover - 1 Pack

Code	Description
HB - 3309048	Nylon Jaw Cover - 1 Pack

FMC John Bean EHP2 - Clamp Jaw Cover - 4 Pack.

Code	Description
EAA0304G20A	FMC JB EHP2 Jaw Cover - 4 Pack



TC0066

Rubber Pad For Hunter Changer. This Is The Replacement Part At The End Of The Jaws Or Clamps Of The Tulip-Style Tire Changers.

Code	Description
TC0066	Rubber Pad For Hunter Changer



COA184712

RC15A Motorcycle Complete Plastic Bootie 4 Pack

Code	Description
COA184712	RC15A Motorcycle Complete Plastic Bootie - 4 Pack

Inserts For Hunter TCX Series Steel Mount/Demount Heads - 10 -Pack - 10 Of Each Insert)

Code	Description
TI11400096	Inserts - Hunter Mount/Demount Head 10 Pack



TI11400096



TIRE CHANGER ACCESSORIES AND PARTS

Replacement Set Of Inserts For The Wonder Bar Mag Wheel Tool. Set Includes One Nose End And One Hook End.

Code	Description
AME - 72010	Mag Wheel Tool Insert Replacement Set



AME - 72010

Short End Cover For Coats COA000768 Coats Tire Bar. Protects Aluminum Rims From Being Scratched.

Code	Description
988	Mount End Protector



988

Long End Cover For Coats COA000768 Coats Tire Bar. Protects Aluminum Rims From Being Scratched.

Code	Description
989	Demount End Protector



989

Coats 9010/9024 Tool Cover 10 Pack. These Units Are To Go Over Each End Of A COA181354 Coats Tire Bar.

Code	Description
COA183605	COA 9010/9024 Tool Cover - 10 Pack



COA183605

Bead Lift Tool Sock For TC181354 - 10 Pack

Code	Description
TC183605	Bead Lift Tool Sock - 10 Pack



TC183605

Coats Type Quilt Clamp SKT 10 Pack. Coats OEM Code 8183604. Protectors For Covering Jaws On All Coats Rim Clamp Tire Changers, Except Coats 9010 And 9024 Changers.

Code	Description
TC183604 - 10	Coats Type Quilt Clamp Skt - 10 Pack



TC183604 - 10

Cemb Nylon Jaw Covers - Set Of 4 For Use On The Cemb Small 815 Tire Changer.

Code	Description
Z - 04100US419	Cemb Nylon Jaw Covers - Set of 4

Flat Style Bead Lifting Tool. Designed For Ease Of Lifting The Head During Tire Changing. Used On Most Rim Clamp Tire Changers. Overall Length 19 - 1/2" X 1 - 1/4"

Code	Description
COA181354	Euro Bead Lifting Tool



COA181354

TIRE CHANGER ACCESSORIES AND PARTS

Flat Style Bead Lifting Tool. Designed For Ease Of Lifting The Head During Tire Changing. Used On Most Rim Clamp Tire Changers. Overall Length 19 - 1/2" X 1 - 1/4"

Code	Description
TC181354	Euro Bead Lifting Tool



TC181354

Flat Style Bead Lifting Tool. Designed For Ease Of Lifting The Head During Tire Changing. Used On Most Rim Clamp Tire Changers. Overall Length 24" X 1 - 1/4"

Code	Description
TC2402	Euro Bead Lifting Tool - 24"



TC2402

Low Profile Bead Lever Tool. Overall Length Of 22" For Better Leverage On Low Profile Tires. Easy Grip Knurled Handle That Is Angled For Maximum Control And Reduces Strain On Users Wrist.

Code	Description
5500	Low Profile Bead Lever Tool



5500

Cover For Euro Style Bead Lifting Tools.

Code	Description
HB - 3312320	Euro Tire Tool Cover



HB - 3312320

Long Sock For TC181354 Bead Lifting Tool - 4 Pack

Code	Description
TC11400098 - 4	Euro Tire Tool Cover - 4 Pack



TC11400098 - 4

BRAKE LATHES PARTS AND ACCESSORIES

Code	Description
CB69	Round Positive Rake Carbide Bit
CB6914 - 10	Negative Rake Carbide Bit
CB7681 - 10	Positive Rake Carbide Bit
CB50742	Positive Rake Carbide Bit
CB29687	Positive Rake Carbide Bit
CB90488	Positive Rake Carbide Bit
CB433796	Positive Rake Carbide Bit - 10 Pack
CB433796P	Premium Positive Carbide Bit
CB109 - 1092 - 23	Positive Rake Carbide Bit
CB221 - 626 - 3	Micro Mini Round Hunter Bit
M175556	CB221 - 626 - 3 Hunter Bit - Screw
BH69L - R	Positive Rake Left - Right Hand Holder
BH10650	Left Hand Tool Bit Holder
BH10651	Right Hand Tool Bit Holder
BH10701	Negative Rake Rght Hand Tool Holder
BH10702	Negative Rake Left Hand Tool Holder



BH10701



CB69



CB433796P



BH10650



CB7681 - 10



CB109 - 1092 - 23



CB29687



BH69L - R



BRAKE LATHES PARTS AND ACCESSORIES

Standard 1" Arbor Nut

Code	Description
AN200	Standard 1" Arbor Nut



AN200

Spindle Protective Boot

Code	Description
SB3085	Spindle Protective Boot



SB3085

Spindle Protective Boot

Code	Description
SB3085RUB	Spindle Protective Boot



SB3085RUB

Small Cloth Protective Feed Screw Boot - Length 10"

Code	Description
SB3086	Small Cloth Protective Screw Boot



SB3086

Large Cloth Protective Cross Feed Boot - Length 8.5"

Code	Description
SB3087	Large Cloth Protective Cross Feed Boot



SB3087

Standard 1" Arbor

Code	Description
AR3101	Standard 1" Arbor



AR3101

Standard 1" Arbor Nut

Code	Description
AN3102	Standard 1" Arbor Nut



AN3102

Red 3 Arm Knob For Ammco Brake Lathes

Code	Description
KB6854	Red 3 Arm Knob



KB6854

Shear Gear And C-Clip For Ammco Brake Lathes

Code	Description
SG7996	Shear Gear And C Clip - For Ammco Brake Lathes



SG7996



BRAKE LATHES PARTS AND ACCESSORIES

Bronze Boot Ring

Code	Description
BR23682	Bronze Boot Ring



BR23682

Brake Lathe Repair Kit - Includes: 3 - BP9836, 1 - BR23682, 1 - BS10, 1 - BS80A, 1 - CB6914 - 10, 1 - KB6854, 1 - SB3085 AND 1 - SG7996.

Code	Description
AS40450	Brake Lathe Repair Kit



AS40450

Heavy Duty 2 - 3/4" Truck Drum Silencer Band - Length 6 Feet

Code	Description
BS5	Heavy Duty 2 - 3/4" Truck Drum Silencer Band



BS5

Adjustable Ventilated Rotor Silencer Band

Code	Description
BS10	Adjustable Ventilated Rotor Silencer Band



BS10

Small Black Solid Rotor Silencer Band - 6 - 9" Diameter - 2 Pack

Code	Description
BS17 - 2	Positive Rake L - R Hand Holder



BS17 - 2

Large Black Solid Rotor Silencer Band - 10 - 12" Diameter - 2 Pack

Code	Description
BS22 - 2	Large Black Solid Rotor Silencer



BS22 - 2

Premium 1 - 3/4" Drum Silencer Band - Length 6 Feet.

Code	Description
BS80A	Premium 1 - 3/4" Drum Silencer Band



BS80A

Clip-On Silencer

Code	Description
CS1	Clip-On Silencer



CS1



BRAKE LATHES PARTS AND ACCESSORIES

Silencer For Procut Lathes

Code	Description
CS5	Silencer For Procut Lathes



CS5

Friction Rotor Silencer Assembly

Code	Description
SB7075	Friction Rotor Silencer Assembly



SB7075

Ventilated Rotor Spring Silencer Assembly - Length 25"

Code	Description
SB9800	Ventilated Rotor Spring Silencer



SB9800

Ammco Brake Lathe 5/16" Wrench

Code	Description
HK15	Ammco Brake Lathe 5/16" Wrench



HK15

Brake Lathe Centering Cone Spring

Code	Description
SP3110	Centering Cone Spring



FMC - 1016845

FMC Brake Lathe - Carriage Feed Nut

Code	Description
FMC - 1016845	FMC Brake Lathe - Carriage Feed Nut

FMC Brake Lathe - Carriage Feed Screw

Code	Description
FMC - 90667	FMC Brake Lathe - Carriage Feed Screw



FMC - 90667

FMC Brake Lathe - Switch On/Off

Code	Description
FMC - 7007631	FMC Brake Lathe - Switch On/Off



FMC - 7007631



BRAKE LATHES PARTS AND ACCESSORIES

Ammco Poly V - Belt

Code	Description
VB40141	Ammco Poly V - Belt



VB40141

6 - 1/2" Alignment Cup 1" Bore

Code	Description
AS3577	6 - 1/2" Alignment Cup 1" Bore



AS3577

7 - 3/4" Alignment Cup 1" Bore

Code	Description
AS3578	7 - 3/4" Alignment Cup 1" Bore



AS3578

Centre Cone (3 - 5/8" - 5 - 1/8") 1" Arbor Hole

Code	Description
AS4778 - 4779	Centre Cone (3 - 5/8" - 5 - 1/8") 1" Arbor Hole



AS4778 - 4779

Centre Cone (5 - 6 - 1/8") 1" Arbor Hole

Code	Description
AS4782A	Centre Cone (5 - 6 - 1/8") 1" Arbor Hole



AS4782A

Silencer Band 10" - 12" Large Disc Rotor. Ventilated

Code	Description
BS35	Silence Band 10 - 12 Large Disc Rotor



BS35

Large Light Truck Centre Cone 4.58 - 4.95"

Code	Description
AS29589	Large Light Centre Cone 4.58" - 4.95"



AS29589

Small Passenger Spring Only. This Spring Would Only Work For Passenger And Light Truck Tires. For 19.5 Tires And Up You Would Need The Spring With More Coils.

Code	Description
AS29591	AS900001A - Small Passenger Spring



AS29591



BRAKE LATHES PARTS AND ACCESSORIES

Centre Cone 1.703 X 2.750 1" Bore

Code	Description
AS3904	Centre Cone 1.703" X 2.750" 1" Bore



AS3904

Rotor Adapter Kit - Machining Late Model F - 150 2 - Wheel Drives With Out Removing The Bearings

Code	Description
AS5532	Rotor Adapter Kit



AS5532

Double Taper Adapter Set - For Passenger Cars And Some Light Trucks

Code	Description
AS9232	Double Taper Adapter Set



AS9232

Economy Light Truck 5-Piece Adapter Set

Code	Description
AS9394	Econo Light Truck 5-Piece Adapter Set



AS9394

Spring Form Economy Light Truck 5-Piece Adapter Set

Code	Description
SP3590	Spring - Econo Light Truck Adapter Set



SP3590

Auto And Light Truck Adapter Set

Code	Description
AS9310	Auto Adapter Set - 11-Pieces



AS9310

Auto Adapter Set

Code	Description
AS9311	Auto Adapter Set - 11-Pieces



AS9311

Light Truck Adapter Set

Code	Description
AS9312	Light Truck Adapter Set



AS9312



BRAKE LATHES

Truck Adapter Set

Code	Description
AS9313	Truck Adapter Set - 9-Pieces



AS9313

Hub And Hubless Adapters For Most Cars Including Composites - Includes SP3125, AS9232, AS9311 And SP9492.

Code	Description
AS900001A	Hub And Hubless Adapters - 18-Pieces



AS900001A

Hub And Hubless Adapters For Cars And Light Trucks Through 1/2 Ton - Includes SP3125, AS9232, AS9310 And SP9492.

Code	Description
AS900002B	Hub And Hubless Adapters - 21-Pieces



AS900003C



AS900002B

Hub And Hubless Adapters For Cars And Light Trucks Through 1 Ton - Includes SP3125, AS9232, AS9233, AS9310, AS9313 And SP9492.

Code	Description
AS900003C	Hub And Hubless Adapters - 32-Pieces

SHOP EQUIPMENT MISCELLANEOUS

Truck Wheel Dolly Reduces Back Injuries In The Shop. 9.5" Roller Accommodates Low Profile Tires. Works On Truck Tire/Wheel Assemblies 19.5 Through 24.5. Lifting Capacity Of 280 Lbs

Code	Description
AME - 71300	Truck Wheel Dolly



AME - 71300

Gaither Wheel Dolly Reduces Back Injuries In The Shop. 3-Position Rollers Accommodates Tire/Wheel Assemblies From 6.5 Through 22.5. Lifting Capacity Of 551 Lbs

Code	Description
GT - G471105	Gaither Wheel Dolly



GT - G471147

Tire Cart. Will Carry Tires From 16 To 35 Diameter.

Code	Description
MTC	Tire Cart



MTC

Winntec Smartcart - Tire Cart. Spring Action Arms Grasp Tires With Minimal Effort

Code	Description
GT - Y471147	Winntec Smartcart - Tire Cart



SHOP EQUIPMENT MISCELLANEOUS

Heavy Duty Tow Bar With Scribe.

Code	Description
99515	Heavy Duty Tow Bar With Scribe



99515

Set Of 12 Siping Blades Are For Use On All TSI Siping Machines.

Code	Description
18 - 071	Siping Blades (One Dozen)



18 - 071

Set Of 12 Siping Groover Blades Are For Use On All Tsi Siping Machines.

Code	Description
65 - 885	Siping Groover Blades 12/Pk



65 - 885

Branick Tool Stand. A Place For Everything At Your Fingertips. Holds Torque Sockets, Hub Cap Removers, Wheel Weight Pliers, Tire Repair Tools, Impact Wrenches And More. Each Side Has 25 Feet Of Recoil Airlines For Impact Wrenches. Tools Not Included.

Code	Description
2400	Branick Tool Stand



2400

OTR Tire Bead Hook - Heavy Duty. Used To Connect With Hydraulic Boom On Tire Service Truck For Transport Of Tires. 16,000 Lbs. Capacity.

Code	Description
AME - 94010	OTR Tire Bead Hook - Heavy



AME - 94010

Jet Vac Truck Tire Casing Evacuator With Hose And Valve. Excellent For Removing Water And Other Debris From Weather Exposed Casings. The Hose Is 4 Feet And Can Be Used To Channel Water To Bucket Or Drain.

Code	Description
JVT	Jetvac Truck Casing Water Evacuator With Hose



JVT

Wheel Stud Thread Gauge Set. Includes 8 Pieces Of The Most Popular Wheel Stud And Nut Sizes Fixed To A Cable. Spin The Nut Onto The Exposed Male Thread To Determine Size. Use Female Port To Thread In Studs Or Bolts.

Code	Description
THRG08	8 Piece Wheel Stud Thread Gauge Set



THRG08

OTR Adjustable Locking Tire Sling. A Fast And Easy Way To Handle Tires In Either Horizontal Or Vertical Position. Endless Chain And Locking Device Makes Positioning Easily Attained. Handles Tires Up To 39" 6500 Lbs. Capacity Per Chain.

Code	Description
AME - 91000	OTR Tire Sling - Adjustable Locking



AME - 91000



SHOP EQUIPMENT MISC

OTR Flange Ring Puller. Features 4 - Point Chain Hook Assembly. Easily Attaches To Boom. Includes 2 Flat Hooks And 2 Tapered Hooks To Allow Use On All Rim Styles. Chain Lengths Of 30"

Code Description
AME - 93000 OTR Flange Ring Puller



AME - 93000

7 Piece Spare Tire Removal Set With Wall Rack. Quickly Removes Spares From 95% Of Pick - Up/SUV Market. Eliminates Searching For Customer's Tool. Use With A 1/2" Drive Ratchet And 7/8" Socket. Do Not Use With An Impact Wrench.

Code Description
AME - 71100 7 Piece Spare Tire Removal Set



AME - 71100

Molded Rubber Wheel Chock For Heavy Trucks, Trailers And Road Construction OTR Tires. Ribbed Pyramid Design. Sold Individually.

Code Description
AME - 15301 Molded Rubber Wheel Chock

Wheel Chock For Mine Support Equipment

Code Description
AME - 15305 Wheel Chock - Mine Support Equipment



AME - 15310

Wheel Chock For Mine Haul Truck Wheels Up To 105" Diameter.

Code Description
AME - 15310 Wheel Chock - Mine Haul Truck



AME - 15320

Wheel Chock For Mine Haul Truck Wheels Over 105" Diameter. Normal Road Grades.

Code Description
AME - 15320 Wheel Chock - Mine Haul Truck



2 - 701

Vanguard High Production And Heavy Duty Application 1/2" Air Filters. This Unit Features 90 CFM Air Flow And An Automatic Internal Drain.

Code Description
2 - 701 1/2" Air Filter 150 Psi 90CFM



2 - 705

Vanguard High Production And Heavy Duty Application 1/2" Air Regulator. This Unit Features 90 CFM Air Flow And Allows Adjustable Pressure. 0 - 300 Psi Bottom Mount Gauge.

Code Description
2 - 705 1/2" Air Regulator 250 Psi 90CFM



2 - 709

Vanguard High Production And Heavy Duty Application 1/2" Air Lubricator. This Unit Features 90 CFM Air Flow And Allows Adjustable Mist.

Code Description
2 - 709 1/2" Air Lubricator 150 Psi 90C



SHOP EQUIPMENT MISCELLANEOUS

Macpherson Strut Spring Compressor. Handles Heavy Coil Shocks With Ease. Longer Handles For Extra Torque. Even Ford F150 And Toyota Rav4 Are No Problem For This Better Than Ever Unit.

Code	Description
7400	MacPherson Strut Spring Compressor



7400

3.5T - 4.5T Jacking Beam. Air Hydraulic. Comes With Support Arms, Extensions 2" And 3 - 3/4" One Year Warranty.

Code	Description
SD40PHL	AC 3.5T - 4.5T Jacking Beam

Manual Tire Pressure Used For Fitting Forklift Rims From Tube Type To Tubeless.

Code	Description
70161	TBS - Manual Tire Press



46 - 728

2-Way OTR Push Bar Tool. Works From The End Of The Truck Boom And Is Used To Depress Or Push Back The Bead Seat Band And Flange Ring For Easier Mount And Demount Of OTR Tires. Fits 25" To 51" Rims. Acts As A Tire Safety Cage When Inflating.

Code	Description
AME - 92000	2-Way OTR Push Bar Tool



AME - 92000

Ken - Tool 27" Truck Valve Breaker. Designed To Break Out Brass Truck Valves With A Slide Hammer Action. Durable And Compact. Heat-Treated Steel For Long Life.

Code	Description
T34B	Ken - Tool 27" Truck Valve Breaker

Ken - Tool 45" Truck Valve Breaker. Designed To Break Out Brass Truck Valves With A Slide Hammer Action. Durable And Compact. Heat-Treated Steel For Long Life.

Code	Description
T36B	Ken - Tool 45" Truck Valve Breaker



T34B

Ken - Tool T34B And T36B Valve Breaker Replaceable Tip Kit. These Are The Replacement Parts For When The Original Tip Is Worn Down Too Low To Be Effective. Easy To Install. Only 3-Pieces.

Code	Description
35935	Ken - Tool Valve Breaker Replacement Tip Kit



T36B

Tsunami Water Separator And Lubricator Bolts On Machine

Code	Description
TI9700	Tsunami Water Separator/Lubricator



TI9700

Tsunami 50 SCFM Water Separator

Code	Description
TI9580	Tsunami 50 SCFM Water Separator



SHOP EQUIPMENT MISC

Water Separator Tool - 1/4" X 10.5 SCFM. Removes 99.9% Of Water Droplets. Auto Drain. 22 Psi To 145 Psi

Code	Description
TI9800	Water Separor Tool - 1/4"

EZ Winder - Winch Winding Tool. Designed To Assist Drivers With Time Consuming Task Of Winding Security Straps On Flatbed Trailers. Use With Cordless Power Drill. Fits All Standard Winches.

Code	Description
40126	EZ Winder - Winch Winding Tool



40126

Hub Shark Bearing And Rotor Pulling System From Ken - Tool. Pull And Press Any Hub Or Bearing On Domestic Or Import Vehicles. Done Completely On Vehicle.

Code	Description
7326	Hub Shark Bear/Rotor Pull System



7326

Standard Tire Rack With Castors

Code	Description
MTD - 60	Standard Tire Rack With Castors

Deluxe Tire Rack With Castors. Dimensions Are 72" L X 20" W X 75" H. 2-Tier Capability That Will Hold 8 Passenger Tires Per Tier. When Loaded This Tire Rack Will Hold 16 Passenger Tires. Loaded Capacity 500Lbs. Black In Colour.

Code	Description
MTD - 72	Deluxe Tire Rack With Castors



MD

Dolly For Tire Disposable. Serves As Both A Handle And Lever For Moving.

Code	Description
MD	Dolly For Tire Disposable

Folding Tire Step. Fits Both 22.5" And 24.5" Truck Tires. Enables You To Create A Step By Placing The Platform On Most Truck Tires. Durable Steel Construction. Maximum Rated To Hold 400 Lbs (181 kgs)

Code	Description
AME - 62030	Folding Tire Step 22.5" And 24.5"



AME - 62030

Rear Wheel Drive/4 Wheel Drive Ball Joint Pressure Remove And Replace Ball Joints Without Brute Force Methods That Cause Costly Damage. This Kit Features A Forcing Screw-Powered Press Kit That Easily Removes And Installs Ball Joints. Includes Durable Carry Case.

Code	Description
72509	RWD/4WD Ball Joint Press Kit



72509



SHOP EQUIPMENT MISCELLANEOUS

AME Gator T - Rack

Code	Description
AME - 75000	AME Gator T - Rack

Universal Nylon Retainer Assortment

Code	Description
OPK23	Universal Nylon Retainer Assortment

Drain Plug Assortment For Newer Car Applications.

Code	Description
DP600	Drain Plug Assortment - 114-Pieces

Ken - Tool Strap Winder - Truck. 4 Tools In 1. The Design Allows Fast And Easy Strap Winding In One Hand. Can Also Be Used For Quick Torque, Tire Check And A Cheater Bar. Steel Construction. Made In The USA .

Code	Description
39760	Ken - Tool Strap Winder - Truck

Universal Bushing Kit. Universal Tool Kit For Mounting And Extracting Silent Bearings, Hydraulic Bearings, Ball Bearings, Shaft Seals, Etc. Includes Sleeves For Inner Diameter 1.3" To 2.8"

Code	Description
AME - 37000	Universal Bushing Kit

Heavy Duty Truck Kit. Universal Tool Kit For Mounting And Extracting Silent Bearings, Hydraulic Bearings, Ball Bearings, Shaft Seals, Etc. Includes Sleeves For Inner Diameter 2.9" - 4.4"

Code	Description
AME - 37050	Heavy Duty Truck Kit



OPK23



DP600



39760



AME - 37000



Tire Service Chemicals And Lubricants



**BEAD BREAKER**

Makes Removing Tires From Rusted Rims Easier. Frees Stubborn Beads Without Special Tools Or Equipment. Easy To Use Anywhere. Prevents Heavy Pounding And Damage To Tire. Simplifies Tire Removal Even On Tire Changers.

Code	Description	Size
A490	Skid Bead Breaker	16oz
B790 - 1G	Skid Bead Breaker	1G
B790 - 5G	Skid Bead Breaker	5G
B790 - 55G	Skid Bead Breaker	55G
BR - 1	Rema Bead Release	1G
BR - 5	Rema Bead Release	5G
BR - 55	Rema Bead Release	55G



BR - 5

A490

B790 - 5G

BEAD SEALER

There Are Two Distinct Bead Sealer Formulations Designed To Prevent Leaks Between The Tire And Rim - Flammable And Non - Flammable. Designed To Be Applied To Tire Beads During The Mounting Process. Ideally Suited For Use With Old Or New Tires. Designed To Help Stop Stubborn Bead Leaks

Code	Description	Size
960	Rema Bead Sealer, With Brush Cap, Non - Flammable	32oz
960ND	Rema Bead Sealer, With Brush Cap, No - Drip	32oz
960F	Rema Bead Sealer, With Brush Cap, Flammable	32oz
PBS - 32	Prema Bead Sealer, Flammable	32oz
777	Premier Performance Bead Sealer, Flammable	32oz
777 - 1	Premier Performance Bead Sealer, Flammable	1G
777 - 5	Premier Performance Bead Sealer, Flammable	5G
KX - 507F	KEX Bead Sealer, Flammable	32oz
RS - 32	Rim Seal Bead Sealer, Flammable	1Q



777



PBS - 32

MOUNTING PASTE

Euro Paste Provides Excellent Lubricity For Mounting And Demounting Tires While Leaving No Mess. Dries Tacky. Non-Petroleum-Based Product. Includes Rust Inhibitor To Protect Inner Rim.

Code	Description	Size
PEP - 8	Prema Euro Paste	8Lbs
PEP - 8N	Prema Euro Paste Low Profile Pail	8Lbs
PEP - 22	Prema Euro Paste	22Lbs
74	74 Mounting Paste	10.0Kg
75	Rema Universal Mounting Paste	7.7Lbs
775	Premier Euro Paste	7.5Lbs



75



775



MOUNTING LIQUID

Economical Liquid Rubber Lubricant. Concentrated Mix Ratio 1:1 To 3:1. Rust Inhibiter Added For Better Rim Protection.

Code	Description	Size
2222 - 1	Concentrated Blue Liquid Tire Lubricant	1G
2222 - 5	Concentrated Blue Liquid Tire Lubricant	5G
2222 - 55	Concentrated Blue Liquid Tire Lubricant	55G



2222 - 1

Murphy's Ready - To - Use Liquid Mounting Lubricant. Easy Application.

Code	Description	Size
2020	Murphy's Liquid Mounting Lubricant	1G
2023	Murphy's Liquid Mounting Lubricant	5G
2022	Murphy's Mounting Lubricant	55G



2110

Murphy's Rim Kote Lubricant. This Corrosion-Resistant Formula Prevents Rusting Wheel Rims As Well As Acting As A Great Mount/Demount Lubricant For Truck Tires. Will Not Freeze.

Code	Description	Size
2110	Murphy's Rim Kote Lubricant	30Lbs

Prema Liquid Blue Concentrated Tire Lubricant

Code	Description	Size
PMLC - 16	Prema Tire Lubricant Liquid Blue Concentrated	16oz



PMLC - 16

Prema Liquid Blue Ready - To - Use Tire Lubricant.

Code	Description	Size
PTL - 1G	Prema 1g Liquid Blue Ready-To-Use Lubricant	



PTL - 1G

Prema Liquid Blue Concentrated Tire Lubricant. This Is A Liquid Rubber Lubricant. Concentrated Mix Ratio 1:1 To 3: Rust Inhibiter Added For Better Rim Protection.

Code	Description	Size
PTLC - 1	Prema Liquid Blue Concentrated Tire Lubricant	1G
PTLC - 2G	Prema Liquid Blue Concentrated Tire Lubricant	2G
PTLC - 5G	Prema Liquid Blue Concentrated Tire Lubricant	5G
PTLC - 55G	Prema Liquid Blue Concentrated Tire Lubricant	55G



PTLC - 2G
(Requires Water Added)



MOUNTING COMPOUND

Murphy's Mounting Tire And Tube Mounting Compound

Code	Description	Size
2005	Murphy's Mounting Compound	25Lbs
2000M	Murphy's Mounting Compound	8Lbs
2008	Murphy's Mounting Compound	40Lbs
2014	Murphy's Mounting Compound	55G



2008

Extra Low Temperature Gel Mounting Compound. Freeze Resistant Gel . Great For OTR Tire Work. Will Hold Its Lubricity Up To - 38°C And Up To 45°C On The High Heat Side. After Mounting, The Gel Will Tack Up. Rust Inhibitor Added.

Code	Description	Size
GX12 - 25	Extra Low Temp Mounting Compound	25Lbs



2023

Tire And Tube Mounting Compound. Excellent Lubricant And Good Bead Pack. Has Rust Inhibitors Added.

Code	Description	Size
1515 - 25	Premium Mounting Compound	25Lbs
2727 - 8	Premier Performance Mounting Compound	8Lbs
2727 - 25	Premier Performance Mounting Compound	25Lbs
2727 - 40	Premier Performance Mounting Compound	40Lbs



2005

Heavy Duty Tire And Tube Mounting Compound. Excellent Bead Pack And Lubricant. Has Rust Inhibitors Added.

Code	Description	Size
2727HD - 8	Premier Performance Heavy Duty Mounting Compound	8Lbs
2727HD - 25	Premier Performance Heavy Duty Mounting Compound	25Lbs
2727HD - 40	Premier Performance Heavy Duty Mounting Compound	40Lbs



2110

Rim Rust Retardant And Tire Mounting Lubricant. Ideal For Aluminum And Steel Wheels

Code	Description	Size
4444 - 5	Premier Performance Black Tire Lubricant With Graphite	5Lbs
4444 - 25	Premier Performance Black Tire Lubricant With Graphite	25Lbs



1515 - 25



4444 - 5



2727HD - 40



2727 - 8



MOUNTING COMPOUND

Black - Ice Mount/Demount Tire Lubricant. Eases Tire Mounting And Demounting. Petroleum Base Compound. Contains Low Voc's. Protects Against Rim Rust And Corrosion. Prevents Rim And Bead From Bonding.

Code	Description	Size
2480 - 25	Black - Ice Mount/Demount Tire Lubricant	25Lbs



2480 - 25

Rema Heavy Duty Tire Mounting Compound For Heavy Duty Applications Where A Bead Pack Is Required For Truck And OTR Tire Mounting/Demounting. Rust Inhibitor Included. Special Dark Brown Formulation.

Code	Description	Size
2280	Rema Heavy Duty Tire Mounting Compound	25Lbs



2280

Rema Tire Mounting Compounds Contain Rust Inhibitors And Will Not Separate Or Liquefy. These Versatile Compounds Function As An Excellent Tire Lubricant And For Tire Bead Packing. Proper Application Provides Damage - Free Removal Of Tires. Concentrated; Water Soluble, Can Be Diluted. Honey Colour

Code	Description	Size
2180X	Rema Tire Mounting Compound	25Lbs



2180X

Rema Tire Mounting Liquid Lubricant. Non - Toxic And Contains No Petroleum Products. Lubricants Can Be Applied By Brush, Swab Or Spray Bottle.

Code	Description	Size
2054B	Rema Bead Butter Blue	5G



2054B

Rema Tire Mounting/Packing Compound. Contains Rust Inhibitors And Will Not Separate Or Liquefy. These Versatile Compounds Function Tire Lubricant And Tire Bead Packing. Extra Thick For Superior Bead Packing On OTR Tires. Makes OTR Tire Mounting Faster And Easier.

Code	Description	Size
2490	Rema OTR Mounting Compound	25Lbs
2178	Rema Tire Mounting Compound	8Lbs
2183	Mounting Compound	40Lbs



2490



TIRE LUBRICANT ACCESSORIES

Extra Long Cotton Swab For Use With Tire Mounting Compounds.

Code	Description
964	15" Tire Swab - Long
2 - 964	Long Tire Swab - 14 - 1/2" .
2 - 965	Standard Tire Swab - 11 - 1/2" .



964



2 - 964



2 - 965

Panther Paste Bead Brush. This Heavy Duty Applicator Brush Allows The Technician To Really Work The Panther Paste Into The Bead And Create Tremendous Lubricity That Will Not Squeegee Off Under Tire Mounting Force.

Code	Description
2121 - BR	Bead Brush - Panther Paste



2121 - BR

Rema Heavy Duty Mounting Paste Brushes Apply Paste, Compound Or Liquid Products Without Mess.

73T	Rema Mounting Paste Brush. 45° 2" Brush head
-----	--



73T

Brush Length 1 - 3/4", Wood Handle Length 7 - 3/4".

971	Angled Euro Paste Applying Brush
-----	----------------------------------



TI1506

Angled Applicator Brush

TI1506	Angled Applicator Brush
--------	-------------------------

1 - 3/4" Truck Tire Paste Brush. 10" Wooden Handle.

TI6350	1 - 3/4" Truck Tire Paste Brush
--------	---------------------------------



971

Solid Wood Handle Is 9" Long And Features A Tapered Tampico Bristle Wound To 3" Long. Overall Length Is 12" Excellent Strength And Longevity. Great For Applying Euro Paste And Other Lubricants.

Code	Description
T401T	Wood Handle Brush - Tampico Bristles



TI6350

Code	Description
PEP - BS	Special Brush For Mounting Paste
PEP - BKN	Bracket - Mounting Paste For Low Profile
PEP - BK	Bracket - Mounting Paste



T401T



PEP - BS

**TIRE AND WHITEWALL CLEANERS**

Whitewall Cleaner. Cleans Whitewalls To A Brilliant White. Will Not Pit Aluminum Rims.

Code	Description	Size
A144	Stoners Whitewall Cleaner	1G

**A144**

More Shine In Less Time. No Wiping, No Mess, No Streaks. Professional Grade.

Code	Description	Size
91044	Stoner Tire Shine Aerosol	12 oz

**91044**

More Shine In Less Time. No Wiping, No Mess, No Streaks. Professional Grade.

Code	Description	Size
91053	Stoner Vinyl Shine Aerosol	12 oz

**91053****FTS21C**

Trim Shine Cleaner And Tire Dressing

Code	Description	Size
91069	Stoner Trim Shine Cleaner	5G
91068	Stoner Trim Shine Cleaner	5G
3333 - 5	Premier Performance Tire Shine	5G

**91069**

Heavy Duty, Fast Acting Cleaner That Quickly Cuts Through Tough Road Grime To Make Wheels, Rims, Whitewalls And Tires Look New. Concentrated For Maximum Economy And Cleaning Power. Suitable For Use On Aluminum, Alloy And Chrome Wheels When Used As Directed.

Code	Description	Size
B548 - 5G	Stoner Wheel/Tire Cleaner	5G
B548 - 55G	Stoner Wheel/Tire Cleaner	55G

**B548 - 5G**

Gunk - Tireshine. No Wiping, No Mess, No Streaks. Professional Grade.

Code	Description	Size
FTS21C	Gunk Tire Shine Aerosol	17 oz

CLEANERS / DEGREASERS

Foaming Wheel Cleaner. Removes Dirt Grime And Brake Dust Leaving An Incredible Shine.

Code	Description	Size
FWC22C	Gunk Foaming Wheel Cleaner	22 oz

**TG1C**

Cleaner/DegreaSeries All Purpose Concentrated Formulation That Comes In A Convenient Trigger Spray Bottle. Removes Grease From Machinery At Full Strength. Non-Toxic, Biodegradable And Non-Corrosive. Pro Strength.

Code	Description	Size
TG1C	Gunk Trigger Gun Cleaner/Degreaser	650ml

**CLEANERS / DEGREASERS**

Engine Brite Degreasers Flammable. Series Heavy Duty Formula Is Packed With Degreasing Solvents That Quickly And Easily Remove The Toughest Grease, Dirt And Grime.

Code	Description	Size
EB1C	Gunk Engine Brite Degreaser	454G



EB1C

Engine Brite Degreasers Quickly And Easily Removes The Toughest Grease, Dirt And Grime.

Code	Description	Size
CEB1C	Gunk Citrus Engine Brite	16 oz

Brake Cleaner. Non Chlorinated. For Disc, Drum, ABS Brakes And CV Joints. Removes Brake Fluid, Oil And Grease. Fast Drying. Contains Heptane.

Code	Description	Size
M705C	Gunk Brake Cleaner	390G
M739C	Gunk Brake Cleaner	5G



M705C

Brake Cleaner. Chlorinated. Environmental Formula - No VOC. Dissolves And Removes Brake Fluid, Oil, Grease And Other Contaminants From All Types Of Brake Assemblies. Non - Flammable. Contains Perchloroethylene And Carbon Dioxides.

Code	Description	Size
AM720C	Gunk Chlorinated Brake Cleaner	510G



M739C

Carb Medic Carburetor Cleaner. Also Cleans Fuel Injectors. Saves Gas.

Code	Description	Size
M4814C	Gunk Carb Medic	354G

Foaming Glass Cleaner. Cleans Windshields And All Glass Windows, Mirrors, Appliances, Chrome, Stainless Steel, Aluminum, Porcelain And Ceramic Tile.

Code	Description	Size
GC1C	Gunk Foaming Glass Cleaner	550G



AM720C

LEAK FINDER

Leak Detector Makes Locating Air Leaks Easier! Quick/Easy Application. Can Be Used On All Types Of Tires, Tubes, Valves And Rims

Code	Description	Size
PLD - 32C	Prema Concentrated Leak Detector	32 oz
PLD - 32	Prema Leak Detector - Ready To Use	32 oz
KLD - 32	KEX Leak Detector - Ready To Use	32 oz

Little Giant 24 oz. Spray Bottle With Orbital Spray Head. Great Spray Bottle For Automotive Liquids Used Everyday In The Field. Unique 360-Degree Orbital Spray Head Allows Great Manouverability Including Spraying Evenly When Upside Down.

Code	Description	Size
969	Spray Bottle With Orbital Head	24 oz



PLD - 32C

969



AIR TOOL OIL

Ingersoll Rand Air Tool Oil.

Code	Description	Size
IR - 50A	Ingersoll Rand Air Tool Oil	500ml



IR - 50A

Code	Description	Size
181 - 00085	Marvel Air Tool Oil	32 oz



181 - 00085

Non-Freezing Air Tool Oil. Non-Petroleum Base So There Will Be No Inner Deterioration Of Air Lines.

Code	Description	Size
ATOOLICEFREE	Non-Freezing Air Tool Oil	1L
ATOOLICE - 16 OZ	Non-Freezing Air Tool Oil	16 oz



ATOOLICEFREE

Killfrost Air Tool Oil 16Oz.

Code	Description	Size
46 - 040	Killfrost Air Tool Oil	16 oz



46 - 040

IR Composite Housing Impactool Care Kit Includes 10Z4 Oil, 4 oz. 115 Grease And Grease Gun

Code	Description
IR - 115 - LBK1	Composite Housing Impact Care Kit



IR - 115 - LBK1

IR Metallic Housing Impactool Care Kit Includes 10Z4 Oil, 4 oz. 105 Grease And Grease Gun

Code	Description
IR - 105 - LBK1	Metallic Housing Impact Care Kit

Blaster Air Tool Conditioner

Code	Description	Size
181 - 00404	Blaster Air Tool Conditioner	1 Box

A True Air Tool Oil, Not A Mild Hydraulic Oil. Recommended For All Makes Of Pneumatic Tools. Use When A Lubricant Possessing Excellent Anti - Wear Properties And Superior Rust And Corrosion Prevention Is Desired.

Code	Description	Size
9999 - 1Q	Red Slip Air Tool Oil	1Q



9999 - 1Q



181 - 00404



- Made in Canada
- OEM Quality Products
- Founded in 1955
- Worldwide Distribution



**Prema Brake Cleaner 390G
PRE8001**



**Prema Brake Cleaner 20L
PRE8201**



**Titan Flexi Film 340G
TNS8010**



**Prema Rim Release 3.78L
PRE8153**



**Titan All Purpose Wash 3.78L
TNS8115**



**Titan Super Penetrating Oil 340G
TNS8005**



**Titan Heavy Duty Degreaser 380G
TNS8008**



**Titan Synthetic Adhesive Spray
Lubricant 330G
TNS8011**



**Titan Multi Purpose Cleaner 920ML
TNS8412**

Contact your Prema Distributor For More Information



**HYDRAULIC OIL**

Hydraulic Jack Oil. Formulated With Extreme Pressure Additives. For Use On All Hydraulic Jacks.

Code	Description	Size
J132C	Gunk Hydraulic Jack Oil	946ml

**J132C**

Hydraulic Oil 1 Gallon Premium Grade. Operating Temperature Range To - 40 Degree Fahrenheit/Celsius. Anti - Wear, Anti - Sludge, Anti - Rust And Anti - Foam Additives. Meets High Performance Hydraulic Oil Grade 32 Requirements. Non-Hazardous Material

Code	Description
AME - 19500	Premium With 32 Grade Hydraulic Oil 1G

**AME - 19500**

Arctic Hydraulic Oil. Heavy Duty Consistency Will Hold Its Coating Value Down To - 50 Degrees. Excellent Choice For Northern Situations And Mines.

Code	Description	Size
HYDOIL - ARC	Arctic Hydraulic Oil	20L

PENETRATING LUBRICANTS

E - Z Break Anti - Seize.

Code	Description	Size
418 - 08910	Markal E - Z Break Anti - Seize	10oz
418 - 08907	Markal E - Z Break Anti - Seize	16oz

**418 - 08910**

PB - B Blaster Penetrating Oil.

Code	Description	Size
PB - B	PB Blaster Penetrating Oil	11oz

**PB - B**

Liquid Wrench - Flammable. The Industry Standard. Super Penetrant. A Powerful Blend Of Quick Acting, Fast Penetrating Solvents That Loosen Rusted Nuts, Bolts And Parts In Seconds.

Code	Description	Size
L112C	Gunk Liquid Wrench	312G

**L112C**

Liquid Wrench - Non - Flammable. Liquid Foaming Penetrant And Lubricant. Unique Foaming Action. As Well As Providing Superior Penetrating And Lubricating Performance, This Product Also Provides Corrosion Protection.

Code	Description	Size
L412C	Gunk Liquid Wrench	255G

**M914C**

Heavy Duty Silicone Spray Compatible With Metals, Rubber, Plastic And Wood. High Viscosity Formula Eliminates Squeaks And Lubricates Both Household And Mechanical Equipment.

Code	Description	Size
M914C	Gunk Silicone Spray	311G



TIRE SEALANTS

Premium Heavy Duty Tire Sealant. For Shop Use, Agricultural Tires, Industrial Fleets, Earthmoving Equipment, Drive Wheels, Logging, Flotation Tires, Etc

Code	Description	Size
119 - 0008	Amerseal Premier Tire Sealant	8oz
119 - 0016	Amerseal Premier Tire Sealant	16oz
119 - 0032	Amerseal Premier Tire Sealant	32oz
119 - 0128	Amerseal Premium Tire Sealant	1G
119 - 0640	Amerseal Premier Tire Sealant	5G
119 - 7040	Amerseal Premier Tire Sealant	55G



119 - 0640



119 - 0032

Code	Description	Size
FS - 35	Flat Stop Tire Sealant	1G

Premier Tire Sealant 5 Gallon. Canadian Made. Holds Air Pressure, Enhances Casing Life And Promotes Retreadability.

Code	Description	Size
1212 - 5G	Premier Tire Sealant	5G
1212 - 16G	Premier Tire Sealant	16G
1212 - 1G	Premier Tire Sealant	1G



FS - 35

TIRE SEALANT ACCESSORIES

Pumps For Tire Sealants

Code	Description	Size
119 - 116	Plastic 1 Gallon Pump	1G
119 - 516	Hand Pump	5G
STXM44	Hand Pump	5G

Fill Kit For 55 Gallon Drum To 5 Gallon Pail. This Kit Comes With 2 Replacement Caps, 1 Tire Valve And 1 Spigot/Faucet. To Properly Pour The Tire Sealant Out Of The Spigot/Faucet You Need To Apply 5 Psi Through The Valve.

Code	Description	Size
119 - 1811	Fill Kit - 55G Drum	5G Pail



1212 - 5G



119 - 516



119 - 0128



1212 - 1G



Solutions in tire storage



Reduce Storage Costs

RiveTier® Brand Automotive Tire Rack is specially designed for durable, economical storage and merchandising of tires. Each unit is designed to allow maximum storage density in a minimum amount of space, with high product visibility. The result is a higher profit per square foot of retail and storage space.

Increase Your Profitability

RiveTier® Brand Tire Rack is heavy-duty steel rack that is priced as economically as wood. It is completely boltless so it can be assembled in minutes, and moved easily whenever necessary. There is no maintenance required and it doesn't sag or splinter, so once installed, it provides a long lasting solution to your tire storage needs.

Improve Efficiency

Tire Rack is attractive enough for the show room and durable enough to use in your warehouse for bulk tire storage.

Individual tires rest in heavy-duty angled beams that support the full weight while holding tires in place. As your needs grow install Add-on units easily and economically to increase your storage capacity.

Your Single Source for Storage and Merchandising Solutions

Western Pacific Storage Systems manufactures a comprehensive line of steel storage systems for the automotive aftermarket industry. Over the years, our products development efforts have resulted in many of the innovations that continue to improve performance in storage, distribution and merchandising.

Tire Rack is constructed from RiveTier® - the original boltless shelving. RiveTier® Tire Rack is available in a variety of sizes and configurations to meet the needs of your application. For product design assistance or information on our complete line of storage and merchandising solutions, contact your sales representative or the factory.

TIRE RACK

- RiveTier® is boltless; it locks together quickly without special tools or equipment.
- Horizontal angled support beams hold tires securely in place - without bars or other locking devices so tires can be easily removed.
- Storage capacity is based on average tire size. Unlike wood units, RiveTier® beams are adjustable on 1 1/2" centers for more flexibility.
- Single entry units are supplied with hardware for wall attachment. Double entry units are free standing.
- Maximize vertical storage by adding up to 6 tier levels high. For bulk storage, Tire Rack can be integrated into two-story catwalk systems.



Automotive Tire Rack organizes stock for better, faster customer service, improved inventory control.



Standard Sizes available



Standard finish is grey, special colors available to match your decor.



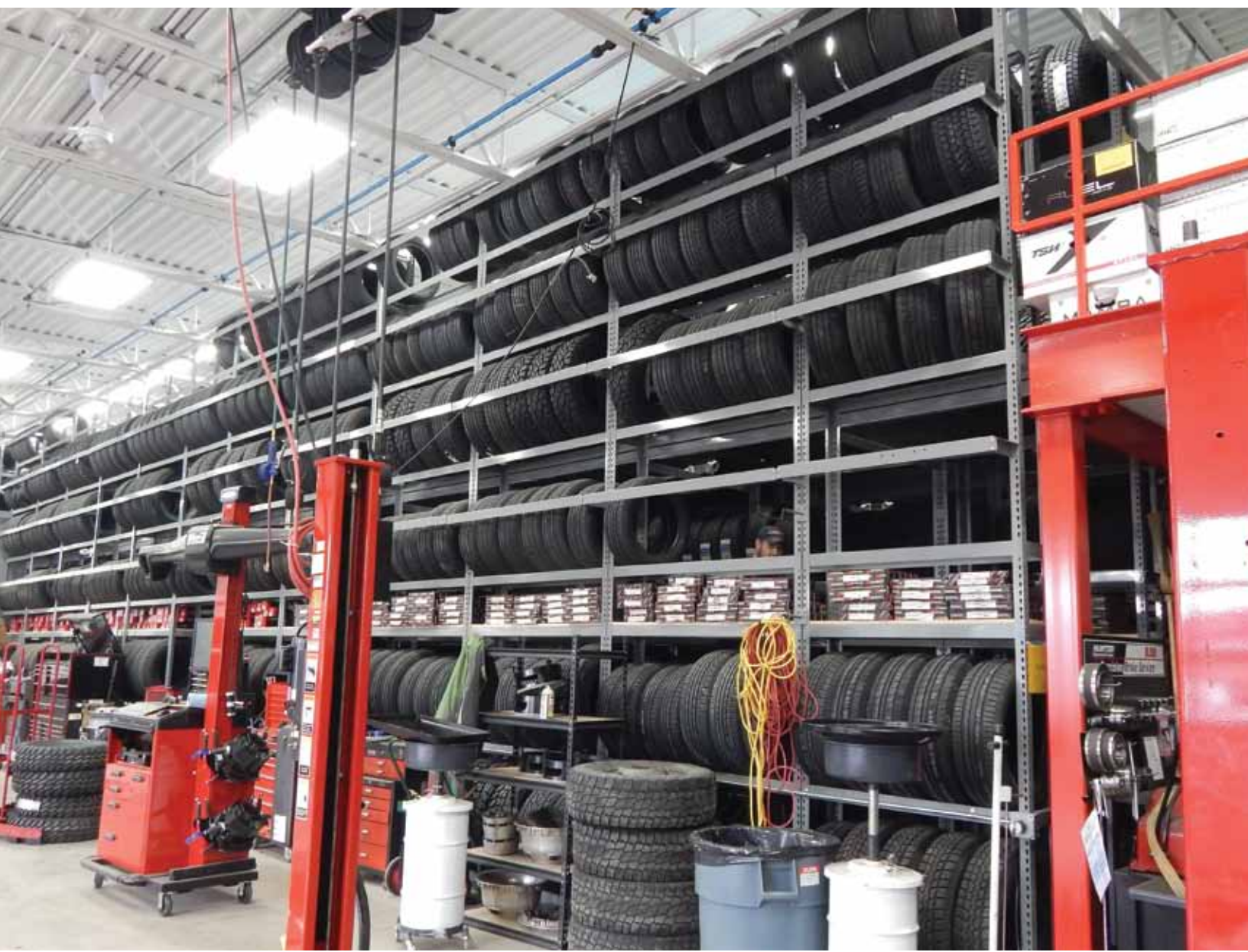

Double Entry

Part No.	Type of Unit	DIMENSIONS			No. of Tiers	Tire Capacity
		Length	Width	Height		
2 DES	Starter	5 ft.	3 ft.	5 ft.	2	32
2 DEA	Adder		6 in			
3 DES	Starter	5 ft.	3 ft.	7 ft.	3	48
3 DEA	Adder		6 in			
4 DES	Starter	5 ft.	3 ft.	10 ft.	4	64
4 DEA	Adder		6 in			
5 DES	Starter	5 ft.	3 ft.	12 ft.	5	80
5 DEA	Adder		6 in			
6 DES	Starter	5 ft.	3 ft.	15 ft.	6	96
6 DEA	Adder		6 in			

Single Entry

Part No.	Type of Unit	DIMENSIONS			No. of Tiers	Tire Capacity
		Length	Width	Height		
2 DES	Starter	5 ft.	1 ft.	5 ft.	2	16
2 DEA	Adder					
3 DES	Starter	5 ft.	1 ft.	7 ft.	3	24
3 DEA	Adder					
4 DES	Starter	5 ft.	1 ft.	10 ft.	4	32
4 DEA	Adder					
5 DES	Starter	5 ft.	1 ft.	12 ft.	5	40
5 DEA	Adder					
6 DES	Starter	5 ft.	1 ft.	15 ft.	6	48
6 DEA	Adder					



Contact Your Prema Distributor For More Information



Tire Service Tools And Accessories





PAINTSTIK AND CRAYONS

Markal B Paintstik. Round Body. Use Holder 8500 Or 85100

Code	Description
80220	Markal Paintstik White
80221	Markal Paintstik Yellow
80222	Markal Paintstik Red
80224	Markal Paintstik Orange
80225	Markal Paintstik Blue
80226	Markal Paintstick Green
80227	Markal Paintstick Pink
80228	Markal Paintstik Purple
80229	Markal Paintstik Brown
80230	Markal Paintstik Gray



80220



80222

Carmel Paintstik

Code	Description
PM - 32303	Carmel Paintstik B - White



PM - 32303

Carmel Paintstik

Code	Description
TM - 30403	Carmel White Tiremark 12/Box
TM - 30403Y	Carmel Yellow Tiremark 12/Box



TM - 30403Y

Markal B Hex White Tire Mark Crayon

Code	Description
80250	Markal B HEX White Tire Crayon



80250

Markal Fluorescent. Ultra High Visibility. All Purpose - Metal, Wood, Glass, Plastic, Rubber. Marks Through Oil And Water. Marking Range - 50° F To 150° F (- 46°C To 66°C). Crayon Size 11/16" X 4 - 3/4".

Code	Description
82831	Fluorescent Marker - Yellow 12/Box
82832	Fluorescent Marker - Red 12/Box
82834	Fluorescent Marker - Orange 12/Box
82835	Fluorescent Marker - Blue 12/Box
82836	Fluorescent Marker - Green 12/Box



82831

Quik Stik Marker White. Fast Drying Long Lasting Marks. Dries In 5 - 7 Minutes. Bright And Bold Marks On Virtually Any Surface. Quik Stik Is Housed In A Plastic Holder With A Built - In Twist Knob To Move It Forward.

Code	Description
61051	Quik Stik Marker 1 - Pack White



80250



PAINTSTIK AND CRAYONS

Laco Markal Pro - Line HP Liquid Paint Marker - White. Writes On All Surfaces. Superior Quality And Leaves A Clear, Permanent Mark. Cuts Through Oils And Soapy Liquids. Can Even Leave Marks On Surfaces That Are In Conditions Of - 50° F.

Code	Description
96960	Pro - Line HP White Liquid Paint Marker



96960

Laco Markal China Marker.

Code	Description
96010	Markal China Marker - White 12/Box
96013	Markal China Marker - Black 12/Box



96010

Laco Trades Marker White 6/Box. All Purpose Markers - Retractable Grease Pencil. Suitable For All Surfaces Like Plastic, Glass, Metal, Wood, Cardboard, Rubber, Paper. Weather Resistant. Will Not Rub Off.

Code	Description
96042	Laco Trades Marker White 6/Box



SIP

Carmel Silver Ink Pen - 12/Box

Code	Description
SIP	Carmel Silver Ink Pen - 12/Box

Valve Paint Marker Yellow. Sold As Each. Same As Markal Valve Action Paint Marker 96821.

Code	Description
PM - 20002	Valve Paint Marker Yellow - Each



PM - 20002

PAINTSTIK AND CRAYONS HOLDERS

Metal Crayon Holder For Hex Body Crayons. Comes With Insert That When Removed Will Allow A Round Body Crayon To Fit As Well.

Code	Description
TI215	Metal HEX Crayon Holder



TI215

Laco Trades Marker Holder. This Is The Tool That Is Required For Housing The 96042 Trades Marker White Refills.

Code	Description
96000	Laco Trades Marker Holder



96000



PAINT STICK AND CRAYON HOLDERS

Markal 5" Standard Holder For B Paintstik, 80220 Or 80221

Code	Description
85000	5" Holder - Standard



85000

Markal 6" Deluxe Holder With Push Button For BPaintstik80220 Or 80221

Code	Description
85100	6" Holder With Push Button



85100

TIRE STUDS

Standard Steel Jacket Tire Studs. Precision Made Units With Carbide Traction Pins Encased In A Wear Resistant Jacket. 9 mm Base X 10 mm High. 1000 Per Box. Shaft Thickness Approximately 5 mm. Use In Passenger/Light Winter Tires. Many Times Holes Are Pre - Drilled.

Code	Description
TS - 11	Tire Studs #11 - 1000/Box
TS - 12	Tire Studs #12 - 1000/Box
TS - 13	Tire Studs #13 - 1000/Box
TS - 15	Tire Studs #15 - 1000/Box
TS - 16	Tire Studs #16 - 1000/Box
TS - 17	Tire Studs #17 - 1000/Box



TS - 12

Aluminum Tire Stud. Standard Aluminum Jacket Tire Studs. Precision Made Units With Carbide Traction Pins Encased In A Wear Resistant Jacket. 9 mm Base X 11 mm High. 1000 Per Box. Shaft Thickness Approximately 5 mm .

Code	Description
11 - ALU - 9	Aluminum Tire Stud # 11
12 - ALU - 9	Aluminum Tire Stud # 12
13 - ALU - 9	Aluminum Tire Stud # 13
15 - ALU - 9	Aluminum Tire Stud # 15
16 - ALU - 9	Aluminum Tire Stud # 16
17 - ALU - 9	Aluminum Tire Stud # 17



15 - ALU - 9

CHECK OUT OUR WEBSITE!

Hope that you find your experience both user friendly and enjoyable. Our goal with the Redesign of our website was to make the information that we give to you easier to find and more timely; as well as delivering it to you on your favorite devices.



TIRE STUDS, PARTS AND EQUIPMENT

Standard Steel Jacket Tire Studs. Precision Made Units With Carbide Traction Pins Encased In A Wear Resistant Jacket. 11 mm Base X 17 mm High. Shaft Thickness Approximately 6 mm Tungsten Tip.

Code	Description
TS - 19	Truck Tire Studs #19 - 500/Box
TS - 21	Truck Tire Studs #21 - 500/Box
TS - 23	Truck Tire Studs #23 - 500/Box

Standard Steel Jacket Tire Studs. Precision Made Units With Carbide Traction Pins Encased In A Wear Resistant Jacket. For Loader Tires. 15 mm Base X 20 mm Length, 8 mm Thickness. Also Has A Tungsten Tip Width Of 4.2 mm .

Code	Description
L - 15	Tire Studs Loader - 15 mm X 20 mm



L - 15

Special Steel Jacket Tire Studs. Multi - Flange. Precision Made Units With Carbide Traction Pins Encased In Wear Resistant Jacket. For Ice Resurfacing Machine Tires. 8 X 15 mm Base. Can Be Inserted With TSIT - 9 Or AS - 9 REG. 9 mm Stud Insertion Tools.

Code	Description
TS - 8X15B	Tire Stud - Ice Resurface Tire



TS - 8X15B

Rally Tire Stud. This Is A Racing Stud That Can Be Used For Cars Or Motorcycles. Multi Flange. 9 mm Base. The Length Does Not Include The Carbide Tip. Use With A Tsit - 9 Or As - 9 Stud Tool And 0700 Drill Bit 0705 Stop.

Code	Description
TS - 9X17R	Rally Tire Stud 9 mm X 17 mm - 500/Box
TS - 9X20R	Rally Tire Stud 9 mm X 20 mm - 500/Box



TS - 9X17R

Rally Tire Stud

Code	Description
TSC - 8 - 13RY	Rally Tire Stud 8 mm X 13 mm - 1000/Box
TSC - 9 - 16 - 6RY	Rally Tire Stud 9 mm X 16.6 mm - 500/Box
TSC - 9 - 19 - 6RY	Rally Tire Stud 9 mm X 19.6 mm - 500/Box



TS - 9X20R

Motorcycle Tire Stud

Code	Description
TSC - 9 - 16MC	MC Tire Stud 9 mm X 16 mm - 500/Box
TSC - 9 - 22MC	MC Tire Stud 9 mm X 22 mm - 500/Box
TSC - 9 - 25MCH	MC Tire Stud 9 mm X 25 mm- 500/Box
TSC - 9 - 18 - 5MCH	MC Tire Stud 9 mm X 18.5 mm - 500/Box



TSC - 8 - 13RY



TSC - 9 - 16MC



SCREW IN TIRE STUDS AND ACCESSORIES

Maxi Grip Tire Stud

Code	Description	
MG - 35100	HM35 - Maxi Grip Tire Stud	100/Box
MG - 30200	HM30 - Maxi Grip Tire Stud	200/Box
MG - 25200	HM25 - Maxi Grip Tire Stud	200/Box
MG - 18200	HM18 - Maxi Grip Tire Stud	200/Box
MG - 18150	HM18 - Maxi Grip Tire Stud	150/Box
MG - 18100	HM18 - Maxi Grip Tire Stud	100/Box
MG - 15200	HM15 - Maxi Grip Tire Stud	200/Box
MG - 15150	HM15 - Maxi Grip Tire Stud	150/Box
MG - 15100	HM15 - Maxi Grip Tire Stud	100/Box
MG - 11150	HM11 - Maxi Grip Tire Stud	150/Box
MG - 11100	HM11 - Maxi Grip Tire Stud	100/Box
MG - 1124	HM11 - Maxi Grip Tire Stud	24/Box
MG - 112420	HM11 - Maxi Grip Tire Stud	24/Box
MG - 351000	HM35 - Maxi Grip Tire Stud	1000/Box
MG - 301000	HM30 - Maxi Grip Tire Stud	1000/Box
MG - 302000	HM30 - Maxi Grip Tire Stud	2000/Box
MG - 252000	HM25 - Maxi Grip Tire Stud	2000/Box
MG - 251000	HM25 - Maxi Grip Tire Stud	1000/Box
MG - 182000	HM18 - Maxi Grip Tire Stud	2000/Box
MG - 181000	HM18 - Maxi Grip Tire Stud	1000/Box
MG - 152000	HM15 - Maxi Grip Tire Stud	2000/Box
MG - 151000	HM15 - Maxi Grip Tire Stud	1000/Box
MG - 112000	HM11 - Maxi Grip Tire Stud	2000/Box
MG - 111000	HM11 - Maxi Grip Tire Stud	1000/Box



MG - 18200



MG - 18100R



MG - 251815

Maxi Grip Tire Stud. Has A Longer Carbide Tip Than The Regular Studs.

Code	Description
MG - 18100R	HM18R - Maxi Grip Tire Stud 100/Box

Maxi Grip Install Tool

Code	Description
MG - 251815	HM25/18/15 Maxi Grip - Install Tool
MG - 303030	HM30 - Maxi Grip Install Tool
MG - 353535	HM35 - Maxi Grip Install Tool
MG - 111111	HM11 - Maxi Grip Install Tool



MG - 45450

Maxi Grip Stud Counter Display . Kit Includes 1 - MG - 111111, 1 - MG - 251815, 1 - MG - 303030, 1 - MG - 353535, 4 - MG - 1124, 2 - MG - 11100, 2 - MG - 15100, 2 - MG - 18100, 2 - MG - 18200, 4 - MG - 30200, 4 - MG - 35100, 1 - MG - 45450 - E

Code	Description
MG - 45450	Maxi Grip Stud Counter Display



MG - 45450 - E

Empty Maxi Grip Counter Display

Code	Description
MG - 45450 - E	Empty Maxi Grip Counter Display



TIRE STUDDING EQUIPMENT AND PARTS

9 mm Stud Installer. Equipped For Automatic Feeding Of Studs To Gun. Handles Stud Sizes 10 Through 17. No Push Rod, Yet Fingers Are Automatically Ejected From Hole.

Code **Description**
TSIT - 9 9 mm Tire Stud Insertion Tool



TSIT - 9

9 mm OKU Stud Gun.

Code **Description**
AS - 9 9 mm OKU Stud Gun



AS - 9

9 mm Tire Stud Tool - Single Or Multi Flange

Code **Description**
EP - 9 9 mm Tire Stud Tool - Single Or Multi Flange

11 mm Stud Installer. Equipped For Automatic Feeding Of Studs To Gun. Handles Stud Sizes 19 Through 23. No Push Rod, Yet Fingers Are Automatically Ejected From Hole. Use With A 4048T Feeder.

Code **Description**
TSIT - 11 Truck Ice Stud Insert Tool 11 mm



TSIT - 11

11 mm OKU Stud Gun

Code **Description**
AS - 11 11 mm OKU Stud Gun



AS - 11

Loader (L - 15) Stud Installer. Equipped For Automatic Feeding Of Studs To Gun. Handles Stud L - 15 Loader Studs. No Push Rod, Yet Fingers Are Automatically Ejected From Hole.

Code **Description**
EP - 15 Tire Studding Tool - Loader L - 15



EP - 15

Tire Stud Insertion Tool. 9 mm Base Studs. Single Or Multi Flange Units. Push Rod (Euro) Style. Bruno Wessel Manufactured.

Code **Description**
BW - PR - 9 Tire Studder 9 mm Single or Multi Flange

Tire Studder 9 mm

Code **Description**
OKU - PR - 9 Tire Studder 9 mm Or Multi Flange



BW - PR - 9



TIRE STUDDING EQUIPMENT AND PARTS

Mini Manual Stud Feeder - 9 mm . Used With Either TSIT - 9 Or AS9 Stud Inertion Tools. Holds Approximately 200 Studs.

Code	Description
4048	Mini Manual Stud Feeder - 9 mm



4048

Mini Manual Stud Feeder - 11 mm . Used With The TSIT - 11 Truck Stud Insertion Tool.

Code	Description
4048T	Mini Manual Stud Feeder - 11 mm



BW - FP9A

Large Stud Feeder, 9 mm With Motor And Feed Hose. Holds Approximately 1000 (1 Box) Of Standard Tire Studs.

Code	Description
BW - FP9A	Large Stud Feeder With Motor And Hose

Large Stud Feeder Without Motor And Hose.

Code	Description
BW - FP9M	Large Stud Feeder

Code	Description	
BW - 0700	Tire Stud Drill Bit (11 - 17)	Tire Stud Drill Bit For Preparing The Appropriate Hole In The Tire For The Tire Stud. This Unit Makes Holes For #11 Through #17 Studs. This Drill Bit Is 3.5 mm Or .1375". The Closest Regular Drill Bit Would Be 9/64", Just Over 1/8" .
BW - 0701	Tire Stud Drill Bit 19 - 21 - 23	Tire Stud Drill Bit For Preparing The Appropriate Hole In The Tire For The Tire Stud. This Unit Is Made To Make Holes For Truck Tire Studs 19 mm , 21 mm Or 23 mm .
BW - 0702	Tire Stud Drill Bit - (L - 15)	Tire Stud Drill Bit For Preparing The Appropriate Hole In The Tire For The Tire Stud. This Unit Is Made To Make Holes For L - 15 Loader Studs.
BW - 0705	Tire Stud Drill Bit Stop (11 - 17)	This Drill Bit Stop Is Used In Conjunction With The BW - 0700 Drill Bit To Assist You In Adjusting The Depth Of The Hole In The Tire.
BW - 0706	Tire Stud Drill Bit Stop 19 - 21 - 23	This Drill Bit Stop Is Used In Conjunction With The BW - 0701 Drill Bit To Assist You In Adjusting The Depth Of The Hole In The Tire.
BW - 0707	Tire Stud Drill Bit Stop - (L - 15)	This Drill Bit Stop Is Used In Conjunction With The BW - 0702 Drill Bit To Assist You In Adjusting The Depth Of The Hole In The Tire.



BW - 0705



BW - 0701



BW - 0700



BW - 0707



BW - 0702



BW - 0706



TIRE STUDS, PARTS AND EQUIPMENT

Floor Stand With Mount For Feeder (Feeder BW - FP9A Not Included), Tire Support, Holster And Cup. Note, The TSIT - 9 Insertion Tool Is Not Included Either.

Code	Description
BW - K5A	Studding Stand Complete



BW - K500A

Complete Studding System. Includes The Studding Stand #BW - K5A, Motorized Feeder #BW - FP9A And Stud Gun # TSIT - 9.

Code	Description
BW - K500A	Complete Studding System

Semi-Automatic Tire Stud Insertion Machine - Inserting Finger Style. Features Built - In Water Jet Sprayer, Mounting Platform, Work Light And Swing Away Tool Tray. Economical And Reduces Operator Fatigue. Overall Dimensions 3' X 4' X 5'.

Code	Description
SATSIM	BW Auto Stud Insertion Machine



SATSIM

Full Rebuild Kit For TSIT - 9

Code	Description
BW - 0381	Stud Gun Small Repair Kit
BW - 0382	Stud Gun Large Repair Kit
BW - 0385	Stud Gun Full Rebuild Kit



BW - 0385

SATSIM Cylinder And Feeder Tube Repair Kit.

Code	Description
BW - 0385 - S	SATSIM Cylinder /Feeder Tube Repair Kit



BW - 0385 - S

SATSIM Part - Insertion Tool

Code	Description
BW - 102003	SATSIM Part - Insertion Tool

SATSIM Part - Metal Feed Tube.

Code	Description
BW - 100138	SATSIM Part - Metal Feed Tube



TIRE STUDS EQUIPMENT AND PARTS

AS9 Stud Gun Parts

Code	Description
BW - 0501	Mandrel - Studding Stand
BW - 0127	9 mm Stud Gun - Metering Levers
BW - 0084	9 mm Stud Gun - External Finger
BW - 0134	9 mm Stud Gun - Compression Spring
BW - 0087	9 mm Stud Gun - OTR Noz. O - Ring
BW - 0089	9 mm Stud Gun Part - R - Ring
BW - 0095	9 mm Stud Gun Part - Spring
BW - 0091	9 mm Stud Gun Part - O - Ring
BW - 0090	9 mm Stud Gun Part - O - Ring
BW - 0092	9 mm Stud Gun Part - Piston Cup
BW - 0132 - 09	9 mm Stud Gun - Gun Head
BW - 0126	9 mm Stud Gun - Inserting Finger
BW - 0088	9 mm Stud Gun - O - Ring
BW - 0096	9 mm Stud Gun - Pin
BW - 0099	9 mm Stud Gun - Sleeve
BW - 0098	9 mm Stud Gun - Trigger
BW - 0161	9 mm Stud Gun - Plastic Feed Hose - 4'
BW - 0383	9 mm Stud Gun - Piston Cup
BW - 0130 - 09	9 mm Stud Gun - Feed Tube
BW - 0103	9 mm Stud Gun - Endless Spring
BW - 0131	9 mm Stud Gun - Tapered Cone
BW - 0135	9 mm Stud Gun - Steel Ring



BW - 0127



BW - 0084



BW - 0087



BW - 0092



BW - 0095



BW - 0519

BW - FP9A Automatic Part - Feeder Wheel. This Is Part #1 On The BW - FP9A Schematic. This Unit Has A Diameter Of 7 - 1/2" X 3 - 3/4" Width.

Code	Description
BW - 0519	BW - FP9A Part - Feeder Wheel

BW - FP9A - Replacement Motor 110. This Is Part #15 On The BW - FP9A Schematic.

Code	Description
BW - 0177 - 110	BW - FP9A - Replacement Motor 110V



BW - 0177 - 110



Shop Supplies

Keep Vehicles Clean. Keep Customers Coming Back.

TIRE BAGS • FLOOR MATS • SERVICE REMINDER SYSTEMS • STEERING WHEEL COVERS • SEAT COVERS • MUCH MORE

Genuine Slip-N-Grip® products help keep vehicles clean during service.

Clean vehicles mean happy customers, and happy customers mean repeat business.



Slipngrip.com • 855-999-4764





PROTECTIVE EYEWEAR AND EYEWEAR

The Professional Choice For Eye Protection Comfort And Fit. Highly Scratch Resistant And Durable. Contoured Brow Guard. Molded Nose Bridge. Adjustable Temple. Black Frame, Clear Lens.

Code **Description**
UVEXB Blaze Pro Safety Glasses



UVEXB

3M Box Series Protective Eyewear. Extremely Comfortable And Meets ANSI Safety Standards. Filters 99.9% UV And Features An Anti - Fog Lens. Silver Black Frame With Clear Lens.

Code **Description**
3M - 11380 3M Box Protective Eyewear



3M - 11380

3M Light Vision 2 Protective Eyewear. Features Two Ultra Bright Adjustable LED Lights. Handsfree Direct Lighting. Meets ANSI Safety Standards. Grey/Black Frames With Clear Anti - Fog Lens.

Code **Description**
3M - 11476 3M Light Vision 2 Protective Eyewear



3M - 11476

3M Light Vision 2 Protective Eyewear. Features Two Ultra Bright Adjustable LED Lights. Handsfree Direct Lighting. Meets ANSI Safety Standards. Grey/Black Frames With Clear Anti - Fog Lens. These Lens Also Are Made With A Prescription +2.5 Diopter.

Code **Description**
3M - 11479 3M Light-Vision 2 Eyewear With Diopter



3M - 11489

3M Light Vision Over-The-Glass Safety Glasses. These Glasses Include The 3M LED Light But Are Specially Designed To Fit Over Your Existing Reading Glasses.

Code **Description**
3M - 11489 3M Over-The-Glass Light Vision



3M - 12166

3M Over-The-Glass Safety Glasses. These Glasses Are Specially Designed To Fit Over Your Existing Reading Glasses.

Code **Description**
3M - 12166 3M Over-The-Glass Safety Glasses

3M Polycarbonate Faceshield With Deluxe Ratchet Headgear. Meets ANSI Safety Standards. Tuffmaster Headgear Is Made In USA . Clear Polycarbonate Shield Is Replaceable (See Code 3M - 82701)

Code **Description**
3M - 82783 3M Face Shield Polycarb With Headgear



3M - 82783

Safety Glasses With Prema Logo. The Spectacles Are Made Of Polycarbonate. Lightweight With Stylish Design. Black Frame With A Prema Logo Screenprinted On The Corner Of One Lens.

Code **Description**
EP1010 - BLACK Safety Glasses With Prema Logo



EP1010 - BLACK

3M Over-The-Glass Safety Glasses. These Glasses Are Specially Designed To Fit Over Your Existing Reading Glasses.

Code **Description**
EP1010 - CLEAR 3M Over The Glass Safety Glasses



EP1010 - CLEAR



PROTECTIVE EYEWEAR AND EARWEAR

3M Replacement Polycarbonate Faceshield. Replaces The Face Guard On Code 3M - 82783. Clear Polycarbonate. Meets ANSI Safety Standards.

Code	Description
3M - 82701	3M Replacement Polycarbonate Faceshield



3M - 82701

3M Push - In Foam Earplugs Highest NRR Of Any Push - In Product At 31dB. Easy Fitting Narrow To Wide Design. Soft - Touch Foam, Sold In Pairs.

Code	Description
3M - 318 - 1002	3M Push - In Foam Earplug 200 Pack



3M - 318 - 1002

3M Optima Over - The - Head Dual Cup Earmuffs. High Block Rating Of NRR 30dB. The Peltor 105 Series Can Handle Noise Ratings Up To 105dBA. Great Quality From 3M.

Code	Description
3M - H10A	3M Optima Dual Cup Earmuffs



3M - H10A

VEHICLE SERVICE PROTECTION

Slip - N Grip Start-Up Kit. Industry Leading Dispenser System. Keeps Interior Car Care Products Within Reach. Locking Castors. This Floor System Contains 250 Seat Covers, 500 Plastic Floor Mats, 500 Part Bags, 250 Steering Wheel Covers, 100 Tire Bags.

Code	Description
3 - SUK	Slip - N Grip - Start-Up Kit

Slip - N Grip - Floor Caddy Only

Code	Description
3 - SUK - E	Slip - N Grip - Floor Caddy Only

Horizontal Repair Order Rack With 13 Slots. Dimensions Are 28" X 13" X 2". Depth Of 5".

Code	Description
M - FB - P9933 - 72	Horizontal Repair Order Rack

Vertical Repair Order Rack With 12 Slots. Dimensions Are 28" X 13" X 2" Depth Of 6".

Code	Description
M - FB - P9933 - 73	Vertical Repair Order Rack



3 - SUK

Slip - N Grip - Wall Rack Start-Up Kit. Industry Leading Dispenser System. Keeps Interior Car Care Products Within Reach. This Wall Rack System Contains 250 Seat Covers, 500 Plastic Floor Mats, 500 Part Bags, 250 Steering Wheel Covers.

Code	Description
3 - SUK - WR	Slip - N Grip - Wall Rack Start-Up Kit



3 - SUK - WR



AUTO SERVICE AND MAINTENANCE SUPPLIES

Slip - N Grip - Wall Rack Only

Code	Description
3 - SUK - WR - E	Slip - N Grip - Wall Rack Only



3 - SUK - WR - E

Plastic Premium Seat Covers. 250 Per Roll. Size 32" X 13" X 42" Thickness 0.7 mm . Clear Film.

Code	Description
3 - SCP - 250	Plastic Seat Covers Prem. 250/RI



3 - SCP - 250

Premium Plastic Seat Covers. 250 Per Box. Dimensions 32" X 14" X 42" Thickness 0.7 mm .

Code	Description
3 - SCPBX - 250	Plastic Seat Covers Premium 250/Box



3 - SCPBX - 250

Economy Seat Covers. 500 Per Roll. Size 32" X 13" X 39" Thickness Clear Film.

Code	Description
3 - SCE - 500	Plastic Seat Covers Economy 500/RI



3 - SCE - 500

Parts Bag - Clear - 11" X 18"

Code	Description
3 - PB - 500	Parts Bag - Clear - 11" X 18"



3 - PB - 500

Floor Mat - Paper Back Only. 500 Per Box. This Is The Most Economic Choice. 60Lbs. Paper Weight. The Size Is 17" X 14".

Code	Description
3 - FMPAPER - 500	Floor Mat - Paper Back Only 500/Box

Great Quality Latex Impregnated 80 Lbs. Paper Floor Mat. Size 17" X 22". 500 Per Box. Wheel In Motion On New Road Graphic. Thanks Your Customer For Business.

Code	Description
3 - FMCNR - 500	Floor Mat Colour, Wheel/New RD 500/Box



3 - FMPAPER - 500



AUTO SERVICE AND MAINTENANCE SUPPLIES

Plastic Floor Mat Standard. 500 Per Roll. Overall Dimension Is 16 - 1/2" X 21".

Code	Description
3 - FMPLAS - 500	Floor Mat - Plastic Standard 500/RI



3 - FMPLAS - 500

Floor Mat Paper Imagemat. 500 Per Box. A Paper Floor Mat Printed In A Customized Design To Promote Your Customer's Business. To Initiate This The Customer Must Provide A .jpeg, .tiff Or .gif File Of Their Company Logo And Information.

Code	Description
3 - FM - IMAGEMAT	Floor Mat Paper Imagemat 500/Box



3 - FMCAB - 175

Floor Mat Paper Cashmat. 500 Per Box. A Paper Floor Mat Printed In A Customized Design To Promote Your Customer's Business And Perforated Coupon Specials. Customer Must Provide A .jpeg, .tiff Or .gif File Of Their Company Logo And Information And/Or Specials They Require.

Code	Description
3 - FM - CASHMAT	Floor Mat Paper Cashmat 500/Box



3 - FM - CASHMAT

SERVICE TAGS, LABELS AND REMINDERS

Key Tags

Code	Description
3 - KTW - 1000	White Key Tag - 1000/Box
3 - KTY - 1000	Yellow Key Tag - 1000/Box

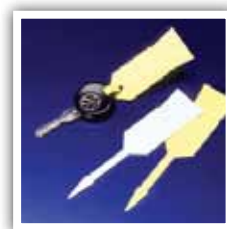

3 - KTW - 1000

Paper Key Tag With Ring

Code	Description
3 - KTPWR - 1000	Paper Key Tag With Ring 1000/Box

Dispatch Numbers Printed On Heavy Card Stock For Durability. Each Unit Is 7.5" X 6.5".

Code	Description
3 - DN - 999	Dispatch Numbers - 000 To 999
3 - DN - 1999	Dispatch Numbers - 1000 To 1999
3 - DN - 2999	Dispatch Numbers - 2000 To 2999
3 - DN - 3999	Dispatch Numbers - 3000 To 3999
3 - DN - 4999	Dispatch Numbers - 4000 To 4999
3 - DN - 5999	Dispatch Numbers - 5000 To 5999
3 - DN - 6999	Dispatch Numbers - 6000 To 6999
3 - DN - 7999	Dispatch Numbers - 7000 To 7999
3 - DN - 8999	Dispatch Numbers - 8000 To 8999
3 - DN - 9999	Dispatch Numbers - 9000 To 9999



3 - DN - 999



AUTO SERVICE AND MAINTENANCE SUPPLIES

Pre-Programmed Printer Cling Labels. Includes CD With Drivers For Printer And Label Design Software. Ribbon Will Last Approximately 1500 Labels. Use With Generic Static Cling Labels. 500 Per Roll.

Code	Description
3 - SRPK	Service Reminder Printer Kit



3 - SRPK

3 - SRPK Service Replacement Printer Kit Ribbon

Code	Description
3 - SRPK - PR	3 - SRPK Replacement Printer Ribbon



3 - SRPK - PR

3 - SRPK Service Replacement Printer Kit Keyboard Cover

Code	Description
3 - KEYCOVER	3 - SRPK Keyboard Cover

Printer Replacement Power Cord To Wall Outlet.

Code	Description
D - FB - R1733 - 87	Printer - Replacement Power Cord



3 - GSCL - 500

Printer Replacement Usb Cable That Connects The Keyboard To The Printer.

Code	Description
D - FB - P9933 - 46	Printer - Replacement USB Cable



3 - CSCL - 500

Generic Static Cling Label. 500 Per Roll. This Is The Label Used In Conjunction With The Pre-Programmed Service Reminder Printer Kit. There Is A Red Oil Can Printed On The Top Of This Label. Comes In A Roll Of 500. Label Size 1 - 1/2" X 2 - 1/2" .

Code	Description
3 - GSCL - 500	Generic Static Cling Label 500/RI

Custom Static Cling Label. 3 Colour Capability Printed On A Clear Static Cling Vinyl. 1 - 1/2" X 2 - 1/2" Cut And Boxed. Approximately 3 Weeks Production Time From Artwork Approval. Customer To Provide Logo And Info In .jpeg, .tiff Or .gif.

Code	Description
3 - CSCL - 500	Custom Static Cling Label - 500/RI
3 - CSCL - 1000	Custom Static Cling Label - 1000/Box

CHECK OUT OUR WEBSITE!

Hope that you find your experience both user friendly and enjoyable. Our goal with the Redesign of our website was to make the information that we give to you easier to find and more timely; as well as delivering it to you on your favorite devices.



VEHICLE SERVICE PROTECTION

Prema Plastic Tire Bag - Large. 250 Per Roll. The Dimensions Of The Bag Are 33" X 6" X 44". Thickness 1.0 mm . Features A Black Prema Logo Screened Onto The White Bag

Code	Description
3 - TBPREMA - 250	Prema Tire Bag - Large 250/RI



3-TBPREMA

Plastic Heavy Duty Tire Bag - Large. 100 Per Roll. The Dimensions Of The Bag Are 33" X 6" X 44". 25% Thicker Than The Other Large Tire Bags.

Code	Description
3 - TBLGHD - 100	Plastic Heavy Duty Tire Bag - Large 100/RI

Plastic Tire Bag - X - Large 125 Per Roll. The Dimensions Of The Bag Are 32" X 15" X 48". The Thickness Of The Ply Is 1.25 mm

Code	Description
3 - TBXLRG - 125	Plastic Tire Bag - X - Large 125/RI



3 - TBXLRG - 125

GM Tire Bag - Large 3. 100 Per Roll. Dimensions 33" X 6" X 44" X 0.8 mm Thickness.

Code	Description
3 - TBGM - 100	GM Tire Bag - Large 100/Roll



3 - TBLRG - IMAGE

Ford Tire Bag - Large 3. 100 Per Roll. Dimensions 33" X 6" X 44" X 0.8 mm Thickness.

Code	Description
3 - TBFORD - 100	Ford Tire Bag - Large 100/Roll



3 - TBSTD - 100

Custom Printed. Size 33" X 6" X 44". Thickness 0.8 mm.

Code	Description
3 - TBLRG - IMAGE	Image Tire Bag - Large 250/Roll
3 - TBXLRG - IMAGE	Image Tire Bag - X - Large 125/Roll

Plastic Tire Bag - Standard. Dimensions 24" X 12" X 40".

Code	Description
3 - TBSTD - 100	Plastic Tire Bag - Standard 100/Roll
3 - TBLRG - 250	Plastic Tire Bag - Large 250/Roll

Tire Bag Large. No Print. 200 Per Roll. Dimensions 33" X 6" X 44". 1.0 mm Thickness.

Code	Description
MFG - P9943 - 28D	Tire Bag Large No Print 200/RI



3 - FC - BL - 10

PVC Fender Cover. Measures 2' X 3'

Code	Description
3 - FC - BL - 10	PVC Fender Cover - Blue 10/Box
3 - FC - RD - 10	PVC Fender Cover - Red 10/Box
3 - FC - BK - 10	PVC Fender Cover - Black 10/Box

Plastic Steering Wheel Covers. 500 Per Box. Double Band ed Style.

Code	Description
3 - SWC - 500	Plastic Steer Wheel Covers 500/Box



3 - SWC - 500



VEHICLE SERVICE PROTECTION

Plastic Truck Steering Wheel Covers. 250/Box. Double Banded Style. These Covers Are 9" Wide But Stretch To 40" Wide. Meant To Fit Big Rigs, Motorhomes And Light Industrial Equipment.

Code	Description
3 - SWCTRK - 250	Steering Wheel Cover Truck Double Band 250/Box



3 - SWCTRK - 250

Plastic Truck Steering Wheel Covers. 500 Per Box. Shower Cap Style. These Covers Are 9" Wide But Stretch To 40" Wide. Meant To Fit Big Rigs, Motorhomes And Light Industrial Equipment.

Code	Description
3 - SWCTRK - 500	Steering Wheel Cover Truck Shower Cap 500/Box

Slip - N Grip - Adhesive Wrap. 36" X 100' Roll. Adheres To Glass, Plastic Or Metal Leaving No Residue Behind. UV Inhibitor - Blue Tinted Film. Puncture Resistant 3.0 Mil Thick.

Code	Description
3 - ADHWRAP - 100	Adhesive Wrap - 36" X 100Ft/Roll



GLOVES - TECHNICIAN / RETREAD / MISCELLANEOUS

Clear Vinyl Glove Non-Powdered 100 Per Box. Industrial Grade. Powder Free And Latex Free.

Code	Description
GPX3 - MD	Clear Vinyl Glove Non-Powdered 100/Box Medium
GPX3 - LG	Clear Vinyl Glove Non-Powdered 100/Box Large
GPX3 - XL	Clear Vinyl Glove Non-Powdered 100/Box Extra Large

GPX3 - LG



3 - NG - SM - 100

Nitrile Gloves. Powder Free. Sold In A Box Of 100 Units. 6 mm Thickness

Code	Description
3 - NG - SM - 100	Nitrile Gloves Small Non-Powdered 100/Box
3 - NG - MD - 100	Nitrile Gloves Medium Non-Powdered 100/Box
3 - NG - LG - 100	Nitrile Gloves Large Non-Powdered 100/Box
3 - NG - XL - 100	Nitrile Gloves Extra Large Non-Powdered 100/Box
3 - NG - 2XL - 100	Nitrile Gloves 2 XL Non-Powdered 100/Box



3 - NG - XL - 100

Nitrile Gloves. Powdered. Sold In A Box Of 100 Units. 6 mm Thickness

Code	Description
3 - NGP - LG - 100	Nitrile Gloves Large With Powder 100/Box
3 - NGP - XL - 100	Nitrile Gloves Extra Large With Powder 100/Box



GPNB - 2XL

Black Nitrile Gloves Non-Powdered.

Code	Description
GPNB - MD	Black Nitrile Glove Non-Powdered - Medium 100/Box
GPNB - LG	Black Nitrile Glove Non-Powdered - Large 100/Box
GPNB - XL	Black Nitrile Glove Non-Powdered - Extra Large 100/Box
GPNB - 2XL	Black Nitrile Glove Non-Powdered - Double Extra Large 100/Box



GPLHD - LG

Heavy Duty Latex 15 Mil 12" -Non-Powdered.

Code	Description
GPLHD - MD	Heavy Duty Latex Glove Non-Powdered - Medium 50/Box
GPLHD - LG	Heavy Duty Latex Glove Non-Powdered - Large 50/Box
GPLHD - XL	Heavy Duty Latex Glove Non-Powdered - Extra Large 50/Box



GLOVES - TECHNICIAN / RETREAD / MISCELLANEOUS

Heavy Duty Nitrile 8 Mil 12" Non-Powdered Glove.

Code	Description
GPNHD - MD	Heavy Duty Nitrile Glove Non-Powdered - Medium 50/Box
GPNHD - LG	Heavy Duty Nitrile Glove Non-Powdered - Large 50/Box
GPNHD - XL	Heavy Duty Nitrile Glove Non-Powdered - Extra Large 50/Box



GPNHD - LG

Nylon Foam Dipped Glove.

Code	Description
C225 - MD	Nylon Foam Dipped Glove - Medium
C225 - LG	Nylon Foam Dipped Glove - Large
C225 - XL	Nylon Foam Dipped Glove - Extra Large



C225 - LG

Gojo Hi-Tactile Gloves

Code	Description
1432 - L	Gojo Hitactile Gloves - Large
1432 - XL	Gojo Hitactile Gloves - Extra Large



1432 - L

IR Mechanic Gloves. These Gloves Are Designed To Last Longer While Providing Excellent Comfort. Durable And Washable. The Clarino Synthetic Palm Allows For Firm Grip Wet Or Dry. The Spandex Top Offers Form Fitting Elasticity And Protection.

Code	Description
IR - GL - 1	IR Mechanic Glove - Large
IR - GXL - 1	IR Mechanic Glove - Extra Large



IR - GL - 1

Boss Leather Palm Work Gloves. Split Leather Palm, Leather Index Finger, Leather Finger Tips, Leather Knuckle Strap And Pull, Wing Thumb, Yellow Cotton Back, Rubberized Safety Cuff. Size Large - But One Size Fits All Situation.

Code	Description
1JL4095YL	Boss Leather Palm Work Glove



1JL4095YL

COX Gauntlet Hot Mould Glove. Short 2 - 1/2" Cuff. For Use In Retread Shops.

Code	Description
COXCG115	COX Gauntlet Retread Hot Mould Glove

COX Gauntlet Hot Mould Glove. Long 5" Cuff. For Use In Retread Shops.

Code	Description
COXCG120	COX Gauntlet Retread Hot Mould Glove



COXCG115



HAND CLEANER AND SKIN CONDITIONER

Prema/Rema Super Hand Cleaner

Code	Description
PHC - SUPER	Prema Super 5L Hand Cleaner
5930443	Rema Super Hand Cleaner 11L
5930450	Rema Soft Hand Cleaner 11L



PHC - SUPER

Gojo Cherry Gel Pumice Hand Cleaner In 1 Gallon Pump Bottle. Contains Skin Conditioners And Is pH Balanced To Promote Skin Comfort. Quickly Cleans Heavy Dirt, Grease And Oil.

Code	Description
2358 - 02	Gojo Cherry Gel Pumice - 1G



2358 - 02

Gojo Cherry Gel Hand Cleaner. Box Of 50, .5 Fl oz Packets In A Display Carton. Contains Skin Conditioners And Is Ph Balanced To Promote Skin Comfort. Quickly Cleans Heavy Dirt, Grease And Oil.

Code	Description
2350 - 02	Gojo Cherry Gel - .5Fl oz Packet



2350 - 02

Gojo Cherry Gel Hand Cleaner. Features Crushed Walnuts Instead Of Pumice. Part Of The Gojo Bag - In - Box System. You Will Receive 2000 ml (Approx. 5Lbs.) Of Hand Cleaner. Simply Replace The Bag Within The Gojo Pro 2000 Dispenser (Gojo Code 7200 - 01)

Code	Description
7290 - 04	Gojo 2,000 ml Cherry Gel Hand Cream



7290 - 04

Gojo Cherry Gel Pumice Hand Cleaner. Contains Skin Conditioners And Is pH Balanced To Promote Skin Comfort. Quickly Cleans Heavy Dirt, Grease And Oil.

Code	Description
2354 - 08	Gojo Cherry Gel - 10 oz Squeeze Bottle
2352 - 15	Gojo Cherry Gel - 6 oz Squeeze Bottle

Gojo Orange Pumice Hand Cleaner. This Is Part Of The Gojo Bag - In - Box System. Simply Replace The Bag Within The Gojo Pro 2000 Dispenser (Gojo Code 7200 - 01)

Code	Description
7255 - 04	Gojo Orange Pumice Hand Cleaner



2354 - 08

Gojo Supro Max Cherry Hand Cleaner. Features Crushed Walnuts Instead Of Pumice. Part Of The Gojo Bag - In - Box System. Simply Replace The Bag Within The Gojo Pro 2000 Dispenser (Gojo Code 7200 - 01)

Code	Description
7282 - 04	Gojo Supro Max Cherry Hand Cleaner

Gojo Supro Max Original Hand Cleaner. Features Crushed Walnuts Instead Of Pumice. Part Of The Gojo Bag - In - Box System. Simply Replace The Bag Within The Gojo Pro 2000 Dispenser (Gojo Code 7200 - 01)

Code	Description
7272 - 04	Gojo Supro Max Original Hand Cleaner



7272 - 04



7282 - 04



HAND CLEANER AND SKIN CONDITIONER

Gojo Power Gold Hand Cleaner. Features Crushed Walnuts Instead Of Pumice. Part Of The Gojo Bag - In - Box System. You Will Receive 2000 ml (Approx. 5 Lbs.) Of Hand Cleaner. Simply Replace The Bag Within The Gojo Pro 2000 Dispenser (Gojo Code 7200 - 01)

Code **Description**
7295 - 04 Gojo Power Gold Hand Cleaner



7255 - D2

Gojo Starter Kit - Orange Pumice Hand Cleaner. Contains 1 - Pro 2000 Dispenser (7200 - 01) And 1 - Orange Pumice Refill (7255 - 04).

Code **Description**
7255 - D2 Gojo Starter Kit - Orange Pumice

Gojo Starter Kit - Supro Max Original Hand Cleaner. Contains 1 - Pro 2000 Dispenser (7200 - 01) And 1 - Supro Max Original Refill (7272 - 04).

Code **Description**
7272 - D2 Gojo Starter Kit - Supro Max Original



7272 - D2

Gojo Starter Kit - Orange Pumice Hand Cleaner. Contains 1 - Pro 2000 Dispenser (7200 - 01) And 1 - Cherry Gel Refill (7290 - 04).

Code **Description**
7290 - D2 Gojo Starter Kit - Cherry Gel

Gojo Hand Medic Pro 500 ml Hand Cleaner. This Is An Excellent Skin Conditioner For Hard Working Hands. As Well As Conditioning, It Also Protects And Restores The Skin.

Code **Description**
8242 - 06 Gojo Hand Medic Pro 500 ml



8242 - 06

Gojo Fine Italian Pumice Hand Cleaner. 4 Lbs. Plastic Cartridge. Creme Formula. Works With The 1204 - 01 Creme - Style Dispensers

Code **Description**
1135 - 06 Gojo Fine Italian Pumice - 4 Lbs

Gojo Starter Kit - Hand Medic Pro Hand Cleaner. Contains 1 - Pro 500 Dispenser (8200 - 12) And 1 - Hand Medic Pro Refill (8242 - 06). Great Way To Get A Customer Started On Your Product.

Code **Description**
8242 - D1 Gojo Starter Kit - Hand Medic



8242 - D1

Gojo Hand Medic Hand Cleaner. This Is An Excellent Skin Conditioner For Hard Working Hands. As Well As Conditioning, It Also Protects And Restores The Skin.

Code **Description**
8145 - 06 Gojo Hand Medic - 8 oz Bottle
8142 - 12 Gojo Hand Medic - 2 oz Bottle



8145 - 06

HAND CLEANER AND SKIN CONDITIONER

Gojo Purell 1000 ml Hand Sanitizer Refill. Sold 8 Per Case

Code	Description
2156 - 08	Gojo Purell 1000 ml Hand Sanitizer



2156 - 08



2120 - 06

Gojo Purell Hand Sanitizer Dispensers. Sold Individually.

Code	Description
2120 - 06	Gojo Purell Sanitizer Dispenser

Gojo Pro 2000 Dispenser Black. This Is The Dispenser That Is Used For The Gojo 2000 ml Bag - In - Box System. The 2000 ml Is Approximately 5 Lbs. Of Hand Cleaner. The Bags Are Very Easy To Load And The Dispenser Is Easy To Operate. Hangs On The Shop Wall.

Code	Description
7200 - 01	Gojo Pro 2000 Dispenser Black



7200 - 01

Gojo Pro 500 Dispenser Black. This Is The Dispenser That Is Used For The Gojo 500ml Bag - In - Box System. The 500 ml Is Approximately 1.25 Lbs. Of Hand Conditioner. The Bags Are Very Easy To Load And The Dispenser Is Easy To Operate. Hangs On The Shop Wall.

Code	Description
8200 - 01	Gojo Pro 500 Dispenser Black



8200 - 01

Gojo Scrubbing Wipes. 72 Per Pack. These Premoistened Wipes Are Dual Textured To Remove The Toughest Grease, Tar And Adhesives. Wipes Contain Skin Conditioners To Prevent Dryness And Irritation.

Code	Description
6396 - 06	Gojo Scrubbing Wipes 72/Pack

Gojo Scrubbing Wipes. These Premoistened Wipes Are Dual Textured To Remove The Toughest Grease, Tar And Adhesives. Wipes Contain Skin Conditioners To Prevent Dryness And Irritation.

Code	Description
6398 - 02	Gojo Scrubbing Wipes 170/Bucket

Gojo Scrubbing Wipes. These Pre - Moistened Wipes Are Dual Textured To Remove The Toughest Grease, Tar And Adhesives. Wipes Contain Skin Conditioners To Prevent Dryness And Irritation.

Code	Description
6383 - 06	Gojo Scrubbing Wipes 25/Pack



6396 - 06

Gojo FMX - 20 Gray Dispenser For 2000 ml Refills. Works With 5261 - 02 Antibacterial Handwash.

Code	Description
5250 - 06	Gojo FMX - 20 Gray Dispenser



5250 - 06



6383 - 06



6398 - 02



HAND CLEANER AND SKIN CONDITIONER

Prema/Rema Hand Soap Dispensers This Will Work Perfectly For Dispensing The Prema PHC - Super.

Code	Description
PHC - DISP	Prema Hand Soap Dispenser
RTT - 5930467	Rema Hand Soap Dispenser



PHC - DISP

WIRE BRUSHES, STRIPPING WHEELS AND ABRASIVE DISCS

Small Handle Brush 3" X 07.006 Stainless Steel Bristles. Toothbrush Style.

Code	Description
SB2088SS	Small Handle Brush 3" X 07.006 SS



SB2088SS

3/8" Tube Fitting Brush. Cleans Fittings Quickly And Easily. Features Stainless Steel Wire Fill And A Comfortable Handle.

Code	Description
EA - 33886	3/8" Tube Fitting Brush
961150	3/8" Tube Fitting Brush



EA - 33894

1/2" Tube Fitting Brush. Cleans Fittings Quickly And Easily. Features Stainless Steel Wire Fill And A Comfortable Handle.

Code	Description
EA - 33894	1/2" Tube Fitting Brush
961210	1/2" Tube Fitting Brush



1" Tube Fitting Brush. Cleans Fittings Quickly And Easily. Features Stainless Steel Wire Fill And A Comfortable Handle.

Code	Description
T175	1" Power Tube Brush 2 - 1/2"



EA - 43513

4 - 1/2" Cyclone Flap Disc. 40 Grit. 5/8" - 11 mm Arbor Hole. Maximum 12000 RPM. Ideal For Weld Blending, Grinding, Cleaning And Finishing.

Code	Description
EA - 43513	4 - 1/2" Cyclone Flap Disc - 40G



Strip - It Disc - 5/8" Arbor Hole Disc Is Bonded To A Rigid Fiberglass Backing Which Allows For Aggressive Grinding And High Operating Pressure. 12400 RPM Max

Code	Description
EA - 90012	SDR 4" Strip - It Disc 5/8" A.H
EA - 90015	SDR 7" Strip - It Disc 5/8" A.H



EA - 90012

Cutoff wheel. 3" x 1/16" x 3/8". 50 per Box

Code	Description
CW1 - 50	Cutoff Wheel 3" X 1/16" X 3/8" 50/Box



3M - 07466



CW1 - 50

3M Strip - It Disc. 4" X 1/2" With 1/4" Shaft.

Code	Description
3M - 07466	3M Strip - It 4" X 1/2" Disc With Shaft



WIRE BRUSHES, STRIPPING WHEELS AND ABRASIVE DISCS

Parts Cleaning Brush Filled With A Crimped Nylon Bristle. The Diameter Of The Bristle Is 1" And The Length Of The Bristle Is 2 - 3/4".

Code	Description
EA - 30452	Parts Cleaning Brush



EA - 30452

3M ABRASIVE DISCS

3M Roloc Disc Holder With 1/4" Shaft. This Holder Is Approximately 2 - 1/2" In Length With A 3/4" Long X 1/4" Diameter. Shaft Moulded Into The Bottom.

Code	Description
3M - 07545	3M Roloc Disc Holder 1/4" Shaft



3M - 07545

3M Roloc 1 - 1/2" Disc. 1 Per Pack Scotch - Brite. Made For Cleaning Rust And Debris From Hard To Get Areas. Nylon Mount Bracket Attached To The Back Of The Disc That Fits Into The 3M - 07545 Holder. 1/2" Turn On And 1/2" Turn Off. Run To Maximum 20000 RPM.

Code	Description
3M - 07546	3M Roloc Disc Kit - 5 Pack With Handle Scotch Brite



3M - 07546

3M Roloc Disc Kit. 5 Per Pack With Handle Scotch - Brite. Brake Hub Cleaning System. Removes Rust And Corrosion Quickly From Hard To Get Areas. Kit Includes 5 - 3M - 07546 Discs And 1 - 3M - 07547 Holder. Designed To Run On High Speed Grinders. Maximum 20000 RPM.

Code	Description
3M - 07547	3M Roloc Disc Kit - 5 Pack With Handle Scotch Brite



3M - 07547

3M Roloc Clean Strip XT 3" Disc. Extra Coarse. Use To Remove Paint, Rust And Seam Sealers Without Excessive Metal Removal Or Gouging Of The Metal.

Code	Description
3M - 07476	3M Roloc Clean Strip 3" Disc



3M - 07476

3M Roloc Disc Holder - Impact Wrench

Code	Description
3M - SA850032	3M Roloc Disc Holder - Impact Wrench
3M - SA260029	3M Roloc Disc Pads 10 Pack - Impact Wrench

Mounting Mandrel - 1/4" Shaft. Will Accept Strip - It Wheels To A Build Of Between 1/2" And 1".

Code	Description
EA - 90011	Strip - It Wheel Mounting Mandrel 1/4" Shaft



EA - 90011

Surface Conditioning Disc. VP Roll - On - Style Mechanical Locking Male Disc. Applications Best For Blending, Deburring And Cleaning On All Types Of Ferrous And Non - Ferrous Metals.

Code	Description
EA - 15334	2" Surface Conditioning Disk - Coarse 25000 RPM
EA - 15336	2" Surface Conditioning Disk - Fine 25000 RPM
EA - 15338	3" Surface Conditioning Disk - Medium 20000 RPM
EA - 15339	3" Surface Conditioning Disk - Fine 20000 RPM



EA - 15334



3M ABRASIVE DISCS

2" Surface Conditioning Disc. Scotch - Brite Surface Conditioning, Non - Woven Web, Provides A Burr Free Finish. Removes Grind Marks, Rust And Coatings. 25000 RPM. Colour Coded To Reflect Grit.

Code	Description
3M - SB05528	2" Surface Conditioning Disc - Coarse
MI197 - 50	2" Surface Conditioning Disc - Coarse
3M - SB05527	2" Surface Conditioning Disc - Medium
MI297 - 50	2" Surface Conditioning Disc - Medium
3M - SB05523	2" Surface Conditioning Disc - Fine
MI397 - 50	2" Surface Conditioning Disc - Fine



3M - SB05528

3" Surface Conditioning Disc. Scotch - Brite Surface Conditioning, Non - Woven Web, Provides A Burr-Free Finish. Removes Grind Marks, Rust And Coatings. Colour Coded To Reflect Grit.

Code	Description
3M - SB05532	3" Surface Conditioning Disc - Coarse. 18,000 RPM
MI17 - 25	3" Surface Conditioning Disc - Coarse. 25,000 RPM
3M - SB05531	3" Surface Conditioning Disc - Medium. 18,000 RPM
MI27 - 25	3" Surface Conditioning Disc - Medium. 25,000 RPM
3M - SB05530	3" Surface Conditioning Disc - Fine. 18,000 RPM
MI37 - 25	3" Surface Conditioning Disc - Fine. 25,000 RPM



MI17 - 25



MI200

Back Pad For Surface Conditioning Disc. Mechanical Roll - On - Style. 1/4" Shaft

Code	Description
MI200	2" Back Pad - Surface Conditioning Disc
MI20	3" Back Pad - Surface Conditioning Disc

Purple HS Blend And Finishing Disc. This Scotch - Brite Roloc Disc Is Highly Flexible And Durable. Made With An Aluminum Oxide Mineral. Constructed In Medium Grade Coarseness. Very Popular 3M Abrasive.

Code	Description
3M - SB64190	2" Purple Blend/Finish Disc. 25,000 RPM
3M - SB64206	3" Purple Blend/Finish Disc. 18,000 RPM



3M - SB64206

2" Roloc Disc Twist - Lock. Provides A Fast, Efficient Method For Grinding, Cleaning, Blending, Levelling And Finishing All Types Of Metal. Aluminum Oxide Cloth. 25,000 RPM. Colour Coded By Grit.

Code	Description
3M - AB11000	2" Roloc Disc 24G Twist - Lock
3M - AB22398	2" Roloc Disc 36G Twist - Lock
MI215 - 100	2" Roloc Disc 36G Twist - Lock
3M - AB22399	2" Roloc Disc 50G Twist - Lock
MI225 - 100	2" Roloc Disc 50G Twist - Lock
3M - AB22400	2" Roloc Disc 60G Twist - Lock
3M - AB22401	2" Roloc Disc 80G Twist - Lock
MI235 - 100	2" Roloc Disc 80G Twist - Lock



3M - AB11000



3M - AB22392

3" Roloc Disc Twist - Lock. Provides A Fast, Efficient Method For Grinding, Cleaning, Blending, Levelling And Finishing All Types Of Metal. Aluminum Oxide Cloth. 25,000 RPM. Colour Coded By Grit.

Code	Description
3M - AB22392	3" Roloc Disc 24G Twist - Lock
3M - AB22393	3" Roloc Disc 36G Twist - Lock
MI315 - 100	3" Roloc Disc 36G Twist - Lock
3M - AB22394	3" Roloc Disc 50G Twist - Lock
MI325 - 100	3" Roloc Disc 50G Twist - Lock
3M - AB22395	3" Roloc Disc 60G Twist - Lock
3M - AB22404	3" Roloc Disc 80G Twist - Lock
MI335 - 100	3" Roloc Disc 80G Twist - Lock



3M - AB22393



3M ABRASIVE DISCS

Twist - Lock Disc. Sanding And Blending Disc. Aluminum Oxide Mini Cloth Disc. Minimum Order Of 100 Units.

Code	Description
EA - 66476	2" Twist - Lock Disc Brown 36G
EA - 66479	2" Twist - Lock Disc Orange 60G
EA - 66488	3" Twist - Lock Disc Brown 36G



EA - 66479

2" Scotch - Brite Bristle Disc. Efficiently Cleans And Strips Many Substances From Metal Without Damaging The Work Piece. Operator Will Only Need To Apply Light Pressure. 25000 RPM. Colour Coded For Grade.

Code	Description
3M - SB18730	2" Bristle Disc 50G Green
3M - SB18732	2" Bristle Disc 80G Yellow
3M - SB18733	2" Bristle Disc 120G White



3M - SB18730

3" Scotch - Brite Bristle Disc. Efficiently Cleans And Strips Many Substances From Metal Without Damaging The Work Piece. Operator Will Only Need To Apply Light Pressure. 15000 RPM. Colour Coded For Grade.

Code	Description
3M - SB18734	3" Bristle Disc 50G Green
3M - SB18736	3" Bristle Disc 80G Yellow
3M - SB18737	3" Bristle Disc 120G White



3M - SB18734

1/4" Shaft - Threaded 1/4" - 20 Male. This Male Adapter Is Used In Conjunction With The 2" And 3" Roloc Disc Pads (See Codes 3M - AB45095 And 3M - AB45092)

Code	Description
3M - AB45102	1/4" Shaft - Threaded 1/4" - 20 Male



3M - AB45102

Roloc Disc Pad Without Adapter. This Unit Is A Backup Rubber Pad For Use On Various 3M Abrasives. The Unit Has A 1/4" - 20 Female Internal Thread To Receive An Adapter (See 3M - AB45102)

Code	Description
3M - AB45095	2" 3M Disc Pad Without Adapter



3M - AB45095

Roloc Disc Pad Without Adapter. This Unit Is A Backup Rubber Pad For Use On Various 3M Abrasives. The Unit Has A 1/4" - 20 Female Internal Thread To Receive An Adapter (See 3M - AB45102)

Code	Description
3M - AB45092	3" 3M Disc Pad Without Adapter



3M - AB45092

2" Scotch-Brite Flap Brush. This Unit's Exact Specifications Are 2" Diameter X 1" Thickness And Has A 1/4" Built-In Shaft. The Texture Grit Is Medium. Maximum 12000 RPM. Great For Cleaning Aluminum Wheels Without Any Chance Of Marring.

Code	Description
3M - SB16622	3" 3M Disc Pad Without Adapter

3" Scotch-Brite Flap Brush. This Unit's Exact Specifications Are 3" Diameter X 1 - 3/4" Thickness And Has A 1/4" Built-In Shaft. The Texture The Texture Grit Is Medium. Maximum 8500 RPM. Great For Cleaning Aluminum Wheels Without Any Chance Of Marring.

Code	Description
3M - SB05974	3" Scotch-Brite Flap Brush



ABRASIVE DISCS - MISCELLANEOUS

Radial Bristle Disc - 50 Green. Full Dimensions 3" Diameter X 3/8" Thickness With A 1/4" Built-In Shaft. Rubberized Strands Are Great For Cleaning Rims Without Marring. Also Far Safer For Operator With No Chance Of Steel Wires Flying Out.

Code	Description
3M - SB24279	3" Radial Bristle Disc - 50 Green



3M - SB24279

GRINDING DISCS

Green Zirconia Disc - 24 Grit (50 Per Box)

Code	Description
MI305 - 50	2" Green Zirconia Disc - 24 Grit
MI308 - 25	3" Green Zirconia Disc - 24 Grit



MI305 - 50

Plug Wheel T - 16. Maximum RPM 18,000. Ideal Abrasive Tool For General Purpose Rough Grinding. A Medium Range Bond System Allows Cooler Cutting Performance.

Code	Description
AD1040	2" x 3" X 5/8" - 11 Plug Wheel T - 16
AD1075	3" X 4" X 5/8" - 11 Plug Wheel T - 16



AD1040

Pipeline Grind Disc. Max RPM 10,200. Can Be Used For Both Cutting And Grinding Applications.

Code	Description
AA1028	5" X 5/32" X 7/8" Arbor Hole Grind Disc
AA1039	6" X 5/32" X 7/8" Arbor Hole Grind Disc



AA1028



CHECK OUT OUR WEBSITE!

Hope that you find your experience both user friendly and enjoyable. Our goal with the redesign of our website was to make the information that we give to you easier to find and more timely; as well as delivering it to you on your favourite devices.



Code	Page	Code	Page	Code	Page	Code	Page	Code	Page
02500	77	110	159	143283006	132	16 - 438	114	20055	47
02529	77	1100K	43	143285003	132	164380500	130	200624	58
08 - A1 - 506	189	111205	114	143285006	133	1645I	123	200624N	58
1000	159	111463	114	1432 - L	261	16 - 510 - 1	114	200624ST	60
10013	80	1125 - 100	86	1432 - XL	261	16 - 511	114	200624STB	60
100360	58	1125 - 105	86	143303003	132	16 - 512	114	200624STR	60
100360B	58	1125 - 110	86	143363003	132	165400001	130	20064	41
100360C	58	1125 - 115	86	143363006	132	165400002	130	20069	41
100360S	58	1130K	43	143383003	132	165400003	130	2008	231
10036W	58	1135 - 06	263	143383006	132	165400006	130	20087	41
100720	58	1137 - 6	198	143403003	132	165400007	130	20098	41
100E818047	133	11 - 603	108	143404003	132	16 - 630	114	2010	115
100E999070	133	11 - 604	108	143404006	133	168 - 01942	85	20107	41
100 - TP	47	11 - 605	108	143405006	133	168 - 10042	85	2010K	43
10140	194	11 - 606	108	143408003	133	168 - 10100	85	20115	41
1025 - 10	50	11 - 607	108	149	123	16 - ALU - 9	246	20116	41
1025C	50	11 - 610	108	1500DW	173	1700	47	20117	41
1025 - U - 10	50	11 - 612	108	1502 - 453	46	170589001	133	2013/PRESTI	115
1026 - 20	50	11 - 626	108	150280008	131	170617002	133	20131	41
1027	43	11 - 635	108	150280009	131	170937002	133	20135	41
1028	43	11 - 636	108	150280010	131	170958001	133	20137	46
1030K	43	117	161	150280012	131	170958002	133	20138	46
10312	164	119 - 0008	239	150280024	132	170958006	133	20139	46
10314	166	119 - 0016	239	150280049	131	170958014	133	2014	231
1031K	43	119 - 0032	239	150280094	131	170988001	133	20140	46
1040K	43	119 - 0128	239	150360008	131	17 - 373	196	20141	46
1042	43	119 - 0640	239	150360009	131	17 - 724	194	20142	46
1043	43	119 - 116	239	150360010	131	17 - ALU - 9	246	20144	47
1045	43	119 - 1811	239	150360012	131	18 - 071	223	20145	46
1046	83	1194	50	150360024	132	181 - 00085	236	20153	41
1048	43	119 - 516	239	150360043	132	181 - 00404	236	20154	46
1048 - HP	43	119 - 7040	239	150360049	131	190008002	133	20158	41
104988038	133	11 - ALU - 9	246	150360085	131	190008005	133	2015MD	174
1050K	43	1201B - 1G	107	150380008	131	190008021	133	20161	41
1051	43	1201B - 1QT	107	150380009	131	190008027	133	2016MD	174
1052	43	1201B - 5G	107	150380010	131	1900 - R	47	2017MD	174
1053	43	1201S - 5G	107	150380012	131	190400061	134	2017MDT	174
1055	43	1204A	43	150380024	132	1905	47	2018MD	174
1056	43	1206A	43	150380049	131	190E008047	133	2018XD	175
105818000	130	1208	43	150380085	131	190E008049	133	20195	47
1060K	43	1209	43	1503TP	173	190E400045	133	2019MD	174
10612	125	1 - 210	105	150400008	131	19 - 200	114	2019MDT	174
10613	126	1212 - 16G	239	150400009	131	193	21	2019MTP	175
10614	126	1212 - 1G	239	150400010	131	194	21	2020	230
1068	43	1214	43	150400011	131	1960	188	2020 - 1	121
10703V	126	1215T	41	150400012	131	1991	188	2020 - 5	121
10704	126	1216	43	150400049	131	1991 - HS&CK	188	2020MD	174
10705	125	122	161	150400110	132	1994	144	2021MD	174
1070K	43	122 - DB	160	1504 - 453	46	1995	188	2021MDT	174
10712	125	123	123	1504 - 572	46	1996	144	2021MTP	175
10713	126	124288000	132	1504 - AN	47	1997	144	2022	230
10714	126	124408005	133	1506 - 453	46	1JL4095YL	261	2022D	174
10722	125	124408006	133	1506 - 572	46	2000	107	2022MD	174
10723	126	12 - 921	114	1508 - 453	46	200009285	134	2022MTP	175
10724	126	12 - 957	114	1508 - 572	46	200009405	134	2023	230
10732	125	12 - ALU - 9	246	1510 - 453	46	20006	44	2024D	174
10733	126	125B	107	1510 - 572	46	2000M	231	2024DT	174
10734	126	1305	41	1511TP	173	2000 - RK10	107	2024MD	174
10742	125	1305 - R	41	1512DM	173	20013	44	2024TP	175
10743	126	1312	173	1515 - 25	231	20017	44	20250	47
10744	126	1312D	173	15 - ALU - 9	246	20018	41	20256	46
10752	125	1319	173	15 - HDL2508	35	20018	44	20257	46
10753	126	13 - 434	160	160280060	132	20019	44	2026D	174
10754	126	1375	147	160280062	132	20020	44	2026DT	174
10770	168	1376	147	160280063	131	200209405	134	2026TP	175
10771	168	1377	147	160400039	134	20021	44	2028D	174
10772	168	1377 - RI	147	160400060	132	200219285	134	2028DT	174
1080K	43	1378	147	160400062	132	20028	41	2028TP	175
10869	164	1378 - R	147	160400063	131	20030	44	2030TP	175
1092	43	13 - ALU - 9	246	160400064	132	20032	44	2030D	174
1093	43	140285003	133	160SI	123	20034	41	2030K	43
1094	43	140403033	133	162 - 233 - 55G	107	20041	44	2030MD	174
1095	43	140404033	133	162S	123	200456285	134	2032D	174
1096	43	140408033	133	164280500	130	200456365	134	2033MD	174
1097	43	1412MD	173	164280507	130	200456385	134	203456405	134
1099	43	14 - 291	109	16 - 436	114	200456405	134	2034D	174
10CR - 3	35	143283003	132	164360500	130	2005	231	2036D	174



Code	Page	Code	Page	Code	Page	Code	Page	Code	Page
2038D	174	2 - 261	193	2 - 903PT	34	3046D	176	3515 - 25	106
20395	47	2 - 263	193	2 - 910	34	3048D	176	3526	159
203CV	22	2269EL	175	2910 - 25	106	304L	122	3537	162
2040D	174	2 - 270	33	29106M	175	304R	122	35440	154
2040K	43	2 - 270P	33	2 - 911	33	305	115	35441	154
2042D	174	2280	232	29146M	175	305 - R	115	35446	144
2045K	43	2 - 280	107	2 - 915	34	306L	122	35447	144
2048D	174	2 - 296	85	2 - 919	34	306R	122	35448	144
20495	50	22 - KIT	23	2 - 920	33	310H	76	356	81
204CV	22	2 - 300 - 7	82	29206F	175	3142D	177	35935	225
205009405	134	2 - 303	85	2 - 921	33	317 - 11 - 3/4	81	36001	124
2052D	174	2 - 306	85	2 - 923	33	31810	130	36002	124
2053B	229	2 - 306L	85	29246F	175	32114	140	36003	124
205456365	134	2 - 322	158	2 - 925	33	32115	140	36010	125
205456405	134	2 - 322 - 10	158	2 - 925AS	33	32118	140	36011	125
2054B	232	2 - 322 - 100	158	2 - 925E	33	32129	143	36012	125
2058D	175	2 - 322 - 30	158	2 - 925RT	33	32130	143	36020	125
20595	47	2 - 322 - 35	158	2 - 925T	33	32131	143	36021	125
205CV	22	2 - 322 - 40	158	2 - 926	33	3213 - 25	106	36022	125
20695	50	2 - 322 - 50	158	2 - 927	33	3218 - 19	106	36080	125
20795	50	2 - 323	158	2 - 928	33	322	80	36085	125
208	161	2 - 324	158	2 - 933	34	3223C	177	377	195
20895	50	2 - 324 - 75	158	2 - 936	35	3241MC	177	3812 - 31	106
20995	47	2 - 325	158	2 - 938	35	33000	41	3814 - 29	106
20 - KIT	23	2 - 325 - 100	158	2 - 939	35	33000B	41	3816 - 28	106
2110	230	2 - 325 - 150	158	2 - 964	233	33000M	41	3818 - 22	106
21 - 100 - 16	111	2346D	175	2 - 965	233	33 - 0709	83	3820 - 24	106
21 - 101 - 36	111	2349D	175	2 - 981	37	331	81	3822 - 25	106
21 - 104 - 16	111	235	123	2 - PPL	34	33100	41	3910S	189
21 - 105 - 36	111	2350 - 02	262	2 - PPS	34	33100B	41	39760	227
21 - 106 - 16	111	2351D	175	2 - RCT	130	33100M	41	39ED	39
21 - 107 - 36	111	2352 - 15	262	2 - RPT	130	33135	177	3 - ADHWRAP - 100	260
2112	43	2354 - 08	262	2 - S871	108	33135HD	177	3 - CSCSL - 1000	258
21134	108	2358 - 02	262	2 - S872	108	33195	154	3 - CSCSL - 500	258
2114MD	174	2392D	175	2 - S872B	108	33196	143	3 - DN - 1999	257
2117MD	174	2400	223	2 - S872S	108	33199	143	3 - DN - 2999	257
2 - 1194	50	2 - 400 - 7	71	2 - S873	108	33200	41	3 - DN - 3999	257
2120 - 06	264	2 - 427	70	2 - S873B	108	33200B	41	3 - DN - 4999	257
2121 - BR	233	2480 - 25	232	2 - S875	108	33200M	41	3 - DN - 5999	257
2130	201	2490	232	2 - S879	108	332056 - 36	111	3 - DN - 6999	257
21310	46	250E131400	134	2 - S879B	108	332058 - 16	111	3 - DN - 7999	257
21315	46	251613409	133	300360	58	332064 - 16	111	3 - DN - 8999	257
21370	46	25K	130	300360ST	60	333	38	3 - DN - 999	257
21380	50	26	23	300360STR	64	3333 - 5	234	3 - DN - 9999	257
2146DT	175	2 - 606	85	3003EB	177	333B	122	3 - FC - BK - 10	259
21 - 515	160	260E111400	134	3003EL	177	333B - BULK	122	3 - FC - BL - 10	259
2156 - 08	264	2 - 6105	80	3007E	177	34000	41	3 - FC - RD - 10	259
2178	232	2688	85	3008A	177	34000	44	3 - FM - CASHMAT	257
2180X	232	2 - 701	224	3009A	177	3400 - 1/2	115	3 - FMCNR - 500	256
2183	232	2 - 705	224	3009AB	177	3400 - 5/8	115	3 - FM - IMAGEMAT	257
2192DT	175	2 - 709	224	3009AL	177	350	159	3 - FMPAPER - 500	256
21 - KIT	23	271804003	133	3010E	177	3500	115	3 - FMPLAS - 500	257
22001	47	271804014	133	3010EB	177	35001	124	3 - GSCL - 500	258
22005	47	271992008	133	3013EB	177	35002	124	3 - KEYCOVER	258
22008	47	271994008	133	301A	70	35003	124	3 - KTPWR - 1000	257
2210E	175	271994208	133	30209	47	35004	124	3 - KTW - 1000	257
22 - 123	159	2727 - 25	231	3024D	176	35005	124	3 - KTY - 1000	257
22 - 133	159	2727 - 40	231	3026D	176	35006	124	3M - 07466	265
22 - 163	159	2727 - 8	231	3028D	176	35007	124	3M - 07476	266
22 - 172	159	2727HD - 25	231	3028MD	176	35010	124	3M - 07545	266
2 - 220	183	2727HD - 40	231	3029MD	176	35011	124	3M - 07546	266
2 - 222	187	2727HD - 8	231	302A	70	35012	124	3M - 07547	266
2222 - 1	230	275	33	3030D	176	35020	124	3M - 11380	254
2222 - 5	230	280280044	134	3030MD	176	35021	124	3M - 11476	254
2222 - 55	230	280400036	134	3032D	176	35022	124	3M - 11479	254
2 - 223	184	280400048	134	3033M	176	35030	124	3M - 11489	254
2 - 224	184	280400049	134	3034D	176	35031	124	3M - 12166	254
2 - 224S	187	280400059	134	3036D	176	35032	124	3M - 318 - 1002	255
2 - 228	185	280400060	134	3036DT	177	35040	124	3M - 61400	61
2228A	175	280400061	134	3036MD	176	35041	124	3M - 61403	61
2238A	175	280400064PN	134	3038D	176	35042	124	3M - 61404	61
22 - 433	159	280400077	133	3038MD	176	3506	162	3M - 61405	61
2243E	175	280400501	134	3040D	176	35060	124	3M - 61458	62
2245E	175	283	107	3040DT	177	35061	124	3M - 61479	62
2247E	175	284	107	3041MD	176	35062	124	3M - 61480	62
2260	201	286	107	3042D	176	3511 - 30	106	3M - 61565	62
22 - 604	71	2 - 903IT	33	3044D	176	3513 - 28	106	3M - 61566	62



Code	Page	Code	Page	Code	Page	Code	Page	Code	Page
3M - 82701	255	4013EL	180	4444 - 25	231	5578	22	687 - P - 50	79
3M - 82783	254	40 - 210 - S	64	444 - 43232	208	5579	22	688 - P - 50	79
3M - 99099	62	40 - 220 - M	63	4444 - 5	231	55TG	39	689 - P - 50	79
3M - 99427	61	4023 - 23	106	444 - 61668	208	5600 - E	183	690	84
3M - 99428	62	4024D	178	46 - 040	236	5600 - PREMA	183	69 - 122	34
3M - 99429	62	40260	127	462F	79	560 - KIT	23	6 - IN	113
3M - 99438	61	402 - AH - 100	84	465	159	56 - 1	39	70	23
3M - 99473	62	4030MD	178	46 - 728	113	5612	106	7001	41
3M - AB11000	267	4030MD	178	476 - 03521	191	5613	106	7001 - R	41
3M - AB22392	267	4033M	178	476 - 35020	191	561 - REFILL	23	7002	41
3M - AB22393	267	4033MD	178	476 - 35021	191	5620313	84	7002 - R	41
3M - AB22394	267	4034D	178	4814 - 44	106	562 - 5088	80	7003	41
3M - AB22394	267	4035MD	178	486 - 71511	130	5656 - 5	107	7004	41
3M - AB22395	267	4035MDT	179	49 - 2	115	5656 - 55	107	700400004	132
3M - AB22398	267	4036D	178	49 - 3	115	5659 - 5	107	700400005	132
3M - AB22399	267	4036DT	179	49 - 5	115	5659 - 55	107	700400007	132
3M - AB22400	267	4036MD	178	500 - 4	194	568 - 011G	79	7004 - R	41
3M - AB22401	267	4038D	178	5008AB	180	570 - 10	68	700E400011	134
3M - AB22404	267	4038MD	178	501 - 100	68	572 - 100	68	700E818012	132
3M - AB45092	268	4040D	178	50301	122	573 - 100	68	700E905012	132
3M - AB45095	268	4040DT	179	50303	122	57 - 5	114	700E958012	132
3M - AB45102	268	4041MDT	179	5033M	180	580 - KIT	23	70161	225
3M - H10A	255	4042D	178	5033MD	180	581 - REFILL	23	702280172	132
3M - SA260029	266	4042DT	179	5048DB	180	5900	182	702360172	132
3M - SA850032	266	4044D	178	5048DSV	180	5930443	262	702380172	132
3M - SB05523	267	4046D	178	509 - 10	71	5930450	262	702400172	132
3M - SB05527	267	4048	250	50F	105	600846	114	702400188	132
3M - SB05528	267	4048D	178	50K	130	600HP	74	702460508	132
3M - SB05530	267	4048DB	179	50KE	130	60100 - 5901	121	702508188	132
3M - SB05531	267	4048DT	179	50 - RB	37	60101 - 5902	121	7027	140
3M - SB05532	267	4048T	250	5103	46	60102 - 5903	121	7092 - 38250	158
3M - SB05974	268	405	115	5112	43	60104 - 7381	121	709AL	122
3M - SB16622	268	4050D	178	5120	38	60105 - 7902	121	70BE958007	132
3M - SB18730	268	4052D	178	5127	80	60106	121	70BE958008	132
3M - SB18732	268	4054D	179	516	192	60107	121	70F	23
3M - SB18733	268	4054D	178	5161180	105	60108	121	70MS - 27	78
3M - SB18734	268	40 - 710	182	5161190	105	6017	109	70MS - 7	78
3M - SB18736	268	40 - 720	182	5175246	118	6018	109	71	23
3M - SB18737	268	412 - 50	67	5175260	118	6055	108	7100	43
3M - SB24279	269	413 - 50	67	5176276	118	6056	108	7125 - H	186
3M - SB64190	267	414 - 50	67	5177300	105	60MS - 27	78	715SI	123
3M - SB64206	267	415 - 50	67	5177310	105	61051	244	715SI - BULK	123
3 - NG - 2XL - 100	260	4155MD	178	5177361	105	6129	85	716SI	122
3 - NG - LG - 100	260	4155MD	179	5177378	105	6175	193	716SI - BULK	122
3 - NG - MD - 100	260	418	123	5199181	38	6218	80	71F	23
3 - NGP - LG - 100	230	418 - 08907	238	5199222	38	627 - 500/BOX	84	71K	130
3 - NGP - XL - 100	260	418 - 08910	238	51F	105	6293 - A	197	71P	130
3 - NG - SM - 100	260	418 - 50	67	5 - 210	105	6293 - B	197	7200 - 01	264
3 - NG - XL - 100	260	419	123	5212	50	6293 - C	198	7229	183
3 - PB - 500	256	4213 - 37	106	5250 - 06	264	6293 - D	198	722SI	123
3 - SCE - 500	256	4214 - 32	106	5260	80	6293 - DILL	197	7248	184
3 - SCP - 250	256	4215 - 35	106	5265	80	63	23	72509	226
3 - SCPBOX - 250	256	4217 - 34	106	5267	80	630 - N	47	725400001	132
3 - SRPK	258	4219 - 30	106	53135	180	635 - 100	47	725400002	132
3 - SRPK - PR	258	4221 - 29	106	531 - 75330	109	6383 - 06	264	7255 - 04	262
3 - SUK	255	4223 - 27	106	5411	85	6396 - 06	264	7255 - D2	263
3 - SUK - E	255	4223C	179	5414	46	6398 - 02	264	7272 - 04	262
3 - SUK - WR	255	4224 - 24	106	5415	46	6410500	130	7272 - D2	263
3 - SUK - WR - E	256	423 - 50	67	54 - 510	115	645L - 6	77	7275	185
3 - SWC - 500	259	4241MC	179	54 - 512	115	647 - 2	160	7275R	185
3 - SWCTRK - 250	260	4246D	178	545 - D	75	6489A	69	7277	183
3 - SWCTRK - 500	260	4246D	179	5500	216	650 - 100	47	7278	187
3 - TBFORD - 100	259	42 - 703	114	55 - 0069	159	653 - 4	160	7282 - 04	262
3 - TBGM - 100	259	43135	179	5500 - BRANICK	37	654	123	7285	186
3 - TBLGHD - 100	259	4313SHD	179	550MP - 3/4	115	6541 - N	83	7285E	186
3 - TBLRG - 250	259	43155	179	550MP - 5/8	115	655 - 143	115	7285R	186
3 - TBLRG - IMAGE	259	43175	179	551	115	6580	116	7290 - 04	262
3 - TBPREMA - 250	259	43195	179	5550	113	6585	116	7290 - D2	263
3 - TBSTD - 100	259	43215	179	5557	43	65 - 885	223	7295 - 04	263
3 - TBXLRG - 125	259	436SI	123	55 - 5X17 - OTR	106	6595	116	729617	114
3 - TBXLRG - IMAGE	259	437SI	123	5561	105	6700	116	729618	114
40 - 0065	159	439SI	123	5563	105	67420	127	730	261
4007EL	180	4415 - 38	106	5567 - 26 5	105	67470	127	7300	43
4008A	179	4416 - 36	106	5570	105	680	84	7326	226
4008AB	179	4417 - 36	106	5571	105	6815	43	733093	114
4010EL	180	4419 - 33	106	5576	22	685 - P - 50	79	7383	81
40126	226	4422 - 29	106	5577	22	686 - P - 50	79	73T	233



Code	Page	Code	Page	Code	Page	Code	Page	Code	Page
74	229	89399	126	96013	245	A - 553D - 10	76	AC - WT1500	165
7400	225	8940158635	103	96042	245	A - 553E - 10	76	AD1040	269
75	229	8940158793	103	960F	229	A - 554C - 10	76	AD1075	269
75H	130	8940158860	103	960ND	229	A - 554D - 10	76	AE050N	54
75K	130	8940162206	103	961150	265	A - 555D - 10	76	A - EV42NI - N	78
75P	130	8940162416	103	961210	265	A - 555E - 10	76	A - EXT125	81
76	23	8940163046	103	964	233	A - 571 - 10	68	A - EXT142	81
760 - KIT	23	8940163099	103	968	107	A - 572 - 100	68	A - EXT40	81
7612	83	8940166760	180	968B	107	A - 573 - 100	68	A - EXT40 - 90D	81
761 - REFILL	23	8940167481	103	969	235	A - 57325	68	A - EXT60	81
76F	23	8940167482	103	96960	245	A - 574 - 10	69	A - EXT84	81
76G	23	89499	126	9700	50	A - 575 - 10	68	AFX - 105B	83
7744	81	89599	126	971	233	A - 591	70	AFX - 105Y	83
775	229	896	158	974	34	A - 592	70	AFX - 145B	83
777	229	89699	126	981 - S	37	A - 6	21	AFX - 145Y	83
777 - 1	229	896L	122	988	215	A - 600HP	74	AFX - 185B	83
777 - 5	229	896R	122	988L 708AR	122	A - 600HPC	74	AFX - 185Y	83
798	35	897	158	988R	122	A - 602	81	AFX - 215B	83
80220	244	897 - 100/BOX	84	989	215	A - 602HP	74	AFX - 215Y	83
80221	244	89799	126	989 - A1 - 501	192	A - 605 - BH	85	AFX - 315Y	83
80222	244	897L	122	993SI	123	A - 605 - N	85	AFX - 415Y	83
80224	244	897R	122	99515	223	A - 60MS9727	78	AFX - 75B	83
80225	244	89899	126	9999 - 1Q	236	A - 618A	70	AFX - 75Y	83
80226	244	89 - GCAP - 100	84	9A	23	A - 618RSI	70	AFX - 85B	83
80227	244	89TRL	159	9T - LB	86	A - 621A	69	AFX - 85Y	83
80228	244	89TRL - 4	159	A - 1075A	79	A - 622A	69	AG107985	204
80229	244	89XDB	199	A - 1078A	79	A - 623A	69	AG1220	108
80230	244	9	23	A - 1175A	79	A - 65658	80	AG66170	204
80250	244	900	33	A144	234	A - 670P	71	AH130	160
8032	176	900008006	130	A - 3	21	A - 673	85	AH132	160
8034D	176	900512	114	A - 34 - 100	79	A - 673L	85	AH232	160
8100	47	901	33	A - 35 - 100	79	A - 673LK	85	AH420	160
8100CB	107	903	33	A - 3 - R	21	A - 675	80	AH430	160
8100PL	107	903RC	33	A - 4.5	21	A - 678	85	AH450	160
8 - 11100108	213	905	33	A - 412 - 100	67	A - 686	198	AH451	160
81240	126	9066K	43	A - 412C	70	A - 687	198	AH453	160
81250	126	907	34	A - 412L	78	A - 688	198	AH462	160
81260	126	908	34	A - 413 - 500	67	A - 689	198	A - J400025	72
81270	126	90MS - 27	78	A - 413C	70	A - 691	197	A - J400045	73
81280	126	91044	234	A - 413CL	70	A - 694	196	A - J400075	73
81290	126	91053	234	A - 413CS - 100	70	A - 695	196	A - J608	80
8142 - 12	263	91068	234	A - 414 - 500	67	A - 696	193	A - J650	72
8145 - 06	263	91069	234	A - 414C	70	A - 698	193	A - J651	73
8153	176	911	33	A - 415 - 100	67	A - 6 - R	21	A - J653	72
8200 - 01	264	914	34	A - 416	74	A770 - 10	158	A - J669	72
8242 - 06	263	9 - 14	86	A - 416L	74	A770 - 25	158	ALG3A099	192
8242 - D1	263	9151	178	A - 417	74	A770 - 50	158	AM720C	235
82831	244	9152	177	A - 418 - 500	67	A772 - 15	158	AME - 11000	150
82832	244	9153	178	A - 418C	70	A772 - 25	158	AME - 11000 - 005	153
82834	244	916	34	A - 423 - 100	67	A772 - 50	158	AME - 11000 - 006	153
82835	244	9161D	178	A - 425 - 100	67	A - 801HP	74	AME - 11000 - 007	153
82836	244	9166L - 8	77	A - 438	67	A - 936A	70	AME - 11005	150
84 - 029	107	918	34	A - 4567	79	A - 936B	70	AME - 11010	149
8500	191	919	34	A490	229	AA1028	269	AME - 11010 - 017	153
85000	246	919SI	122	A - 500 - 10	68	AA1039	269	AME - 11010 - 022	153
8500 - D	191	920SI	122	A - 50023	78	A - AD1	80	AME - 11010 - 045	153
85100	246	921	33	A - 501 - 100	68	A - B6 - 50	79	AME - 11010 - 048	153
85K	130	925	33	A - 501 - OV	74	A - BL39MS83	78	AME - 11010 - 050	153
86250	127	925AS	33	A - 509 - 10	71	A - BLV302	78	AME - 11010 - 051	153
874 - 6	115	926	33	A - 510 - 10	71	A - BLV303	78	AME - 11010 - 052	153
8808A	79	9263	180	A - 511 - 10	71	A - BLV421 - 2	78	AME - 11010 - RK	153
8810 - H	188	927	33	A - 523MS	74	A - C1 - 100	86	AME - 11015	149
8810 - J	186	9300	47	A - 523MS - HN	74	A - C1 - 100 - N	86	AME - 11020	149
881M	122	930 - SC	47	A - 543 - 10	75	A - C1 - HT - 100	84	AME - 11030	150
885	79	932004 - 330	111	A - 543D - 10	75	A - C1 - HT - 100 - N	84	AME - 11040	149
8860 - C	191	932005 - 330	111	A - 544 - 10	75	A - C1 - HT - L100N	84	AME - 11043	153
8888	159	932088 - 390	111	A - 544D - 10	75	A - C1 - LF - 20	84	AME - 11044	150
890	158	933	34	A - 544E - 10	75	A - C2	74	AME - 11050	150
8909	85	935	35	A - 545 - 10	75	AC - 25 - 2	165	AME - 11060	149
8910	47	936	35	A - 54536 - 10	75	AC - 25 - 2TH	165	AME - 11065	151
8911	47	940	109	A - 545D - 10	75	AC - 50 - 2	165	AME - 11075 - 021	153
89199	126	941	109	A - 545E - 10	75	AC - 50 - 2TH	165	AME - 11075 - 022	153
891AR	122	942	109	A - 546D - 10	75	AC - B25 - 2	165	AME - 11075 - RK	153
891 - THR	158	95K	130	A - 547D - 10	75	ACCU - SM101608	212	AME - 11076	149
892	158	960	229	A - 552 - 10	76	AC - DK20	165	AME - 11080	151
89299	126	96000	245	A - 553 - 10	76	AC - DK20Q	165	AME - 11090	150
892AL	122	96010	245	A - 553C - 10	76	A - CH3	69	AME - 11900	149



Code	Page	Code	Page	Code	Page	Code	Page	Code	Page
AME - 13000	166	AME - 62050	129	A - VC8 - 100	84	B580A	218	CB433796P	216
AME - 13010	151	AME - 62500	129	A - VC8G - 100	84	BTP - E844 - 5G	107	CB50742	216
AME - 13020	151	AME - 62550	129	A - VC8G - S - 100	84	BW - 0084	252	CB69	216
AME - 13030	151	AME - 62600	127	A - VC8 - S - 100	84	BW - 0087	252	CB6914 - 10	216
AME - 13040	151	AME - 62610	127	A - VS8	77	BW - 0088	252	CB7681 - 10	216
AME - 13050	151	AME - 62955	127	A - VS8 - 6MM	77	BW - 0089	252	CB90488	216
AME - 13060	151	AME - 69250	208	A - VS8D45	77	BW - 0090	252	CC - 10	33
AME - 13070	151	AME - 69260	123	A - VS8D90	77	BW - 0091	252	CC - 4 5	33
AME - 13090	151	AME - 69290	121	A - VS8L	77	BW - 0092	252	CC - 6	33
AME - 13100	151	AME - 71050	154	AW025	54	BW - 0095	252	CC - 8	33
AME - 13120	164	AME - 71051	154	AW025 - 50	54	BW - 0096	252	CEB1C	235
AME - 13140	166	AME - 71052	154	AW025N	54	BW - 0098	252	CH10	145
AME - 13150	166	AME - 71100	224	AW050	54	BW - 0099	252	CH10AL	145
AME - 13155	166	AME - 71300	222	AW050 - 50	54	BW - 0103	252	CH13AL - MTO	145
AME - 13210	151	AME - 71500	144	AW075	54	BW - 0126	252	CH2	144
AME - 13220	151	AME - 71600	151	AW075 - 50	54	BW - 0127	252	CH22	209
AME - 13520	166	AME - 72000	204	AW075N	54	BW - 0130 - 09	252	CH22 - 10065	209
AME - 14140	167	AME - 72010	215	AW100	54	BW - 0131	252	CH22 - 41002	209
AME - 14160	167	AME - 72100	209	AW100 - 50	54	BW - 0132 - 09	252	CH22 - JP - SET	209
AME - 14180	168	AME - 73080	37	AW100N	54	BW - 0134	252	CH23	209
AME - 14350	164	AME - 73100	37	AW125N	54	BW - 0135	252	CH - 360	198
AME - 14360	170	AME - 73200	37	AW150	54	BW - 0161	252	CH - 360 - OP	198
AME - 14370	164	AME - 73210	121	AW150 - 50	54	BW - 0177 - 110	252	CH - 360 - OP - RK	195
AME - 14400	170	AME - 75000	227	AW150N	54	BW - 0381	251	CH - 360 - RK	194
AME - 14460	164	AME - 91000	223	AW175	54	BW - 0382	251	CH - 370 - LO	193
AME - 14464	170	AME - 92000	225	AW175N	54	BW - 0383	252	CH4	209
AME - 14465	171	AME - 93000	224	AW200	54	BW - 0385	251	CH5	144
AME - 14468	171	AME - 94010	223	AW200N	54	BW - 0385 - S	251	CH5 - 01 - 106	147
AME - 14470	164	AN200	217	AW225	54	BW - 0501	252	CH5 - 01 - 107	147
AME - 14475	164	AN3102	217	AW225N	54	BW - 0519	252	CH5 - 02 - 102	147
AME - 14720	169	APOLLO - II	114	AW250	54	BW - 0700	250	CH5 - 02 - 103	147
AME - 14980	169	APOLLO - II DET	114	AW250 N	54	BW - 0701	250	CH5 - 03 - 104	147
AME - 15000	152	APOLLO - III	114	AW275	54	BW - 0702	250	CH5 - 04 - 103	147
AME - 15002	170	AR3101	217	AW275N	54	BW - 0705	250	CH5AL	144
AME - 15012	170	A - RG15	79	AW300	54	BW - 0706	250	CH60	145
AME - 15022	170	A - RG39	79	AW300N	54	BW - 0707	250	CH60 - LT	145
AME - 15032	170	A - RG46	79	B - 10	21	BW - 100138	251	CHR - 1	199
AME - 15090	155	A - RG54	79	B - 10 - R	21	BW - 102003	251	CL12	58
AME - 15100	155	A - RG60	79	B3033001GRIP	138	BW - FP9A	250	CL6	58
AME - 15200	171	A - RG70	79	B548 - 55G	234	BW - FP9M	250	CLFY19	127
AME - 15210	171	AS - 11	249	B548 - 5G	234	BW - K500A	251	CLFY24	127
AME - 15220	171	AS29589	220	B790 - 1G	229	BW - K5A	251	CLFY27	127
AME - 15230	171	AS29591	220	B790 - 55G	229	BW - PR - 9	249	CLFY30	127
AME - 15240	171	AS3577	220	B790 - 5G	229	C - 10	115	CLFY32	127
AME - 15250	171	AS3578	220	B - 8 - R	21	C - 2	115	CLFY33	127
AME - 15255	171	AS3904	221	BC - 04	153	C225 - LG	261	CLS27	127
AME - 15260	171	AS40450	218	BH10650	216	C225 - MD	261	CLS30	127
AME - 15301	224	AS4778 - 4779	220	BH10651	216	C225 - XL	261	CLS32	127
AME - 15305	224	AS4782A	220	BH10701	216	C26 - 22	161	CLS33	127
AME - 15310	224	AS5532	221	BH10702	216	C - 30	115	CO - 111R	162
AME - 15320	224	AS - 9	249	BH69L - R	216	CA - 087404	103	CO8H72	198
AME - 15905	152	AS900001A	222	BL - 32	22	CA - 088097	103	COA059408	214
AME - 15920	152	AS900002B	222	BL - 5F	22	CA - 094791	103	COA107517	204
AME - 15940	152	AS900003C	222	BL - 8	22	CA - 124745	103	COA108276	205
AME - 16030	152	AS9232	221	BL - 8F	22	CA - 131501	103	COA110542	208
AME - 16050	152	AS9310	221	BL - G	22	CA - 139818	103	COA112568	208
AME - 16060	152	AS9311	221	BLVC22 - PINK	84	CA - 145228	103	COA181354	215
AME - 16070	153	AS9312	221	BR - 1	229	CA149158	103	COA181788	207
AME - 16150	152	AS9313	222	BR23682	218	CA - 154948	103	COA182247	210
AME - 16200	152	AS9394	221	BR - 5	229	CA - 155537	103	COA182339	207
AME - 16270	152	ASP - 10	80	BR - 55	229	CAB01	135	COA183355	212
AME - 17200	152	A - SP2	71	B507	145	CAB02	135	COA183374	214
AME - 19500	238	ATOOLICE - 16 OZ	236	B507 - 01 - 106BS	147	CAB03	135	COA183604	212
AME - 24100	199	ATOOLICEFREE	236	B507 - 01 - 230BT	147	CAB04	135	COA183605	215
AME - 24145	182	AT - TS55	44	B507 - 05 - 102	147	CAB05	135	COA183606	206
AME - 25100K	169	A - TVCT	46	B507 - 3 - 102	147	CAB06	135	COA183680	207
AME - 25110K	169	A - V2 - 04 - 1	78	B507 - 6813	147	CAB08	135	COA183811	205
AME - 25120K	169	A - V3 - 14 - 3V	78	B510	218	CAB10	135	COA184052	207
AME - 25130K	169	A - V3 - 20 - 1	77	BS - 1314	144	CAB12	135	COA184712	214
AME - 25150K	169	A - V3 - 20 - 4	77	BS - 1415	144	CAB14	135	COA184926	210
AME - 37000	227	A - V3 - 20 - 5	77	BS - 16	144	CAB16	135	COA308820	208
AME - 37050	227	A - V3 - 20 - 6	77	BS - 17	144	CAB - AIB	135	COA9209612	212
AME - 51290	130	A - VC12 - 100	84	BS17 - 2	218	CAB - MK1/2	135	COXCG115	261
AME - 51460	130	A - VC13 - 100	84	BS - 18	144	CAB - MK2/2	135	COXCG120	261
AME - 51480	130	A - VC14 - 100	84	BS - 20	144	CAB - VC8R - 100	84	CP26 - 24	161
AME - 51550	208	A - VC15 - 100	84	BS - 22	144	CB109 - 1092 - 23	216	CP - 7110	100
AME - 52000	122	A - VC42G - 20	84	BS22 - 2	218	CB221 - 626 - 3	216	CP - 717K	100
AME - 62000	129	A - VC6	80	B535	220	CB29687	216	CP - 719	98
AME - 62030	226	A - VC7	80	B55	218	CB433796	216	CP - 724H	98



Code	Page	Code	Page	Code	Page	Code	Page	Code	Page
CP - 72655	99	CTR28	128	DTS627	129	EX - 1273	74	EX - 2012	78
CP - 734H	98	CTR29	128	DTS628	129	EX - 1276	74	EX - 2018	78
CP - 749	100	CTR30	128	DTS630	129	EX - 1280A	82	EX - 3006	79
CP - 749 - 2	100	CTR31	128	DTS632	129	EX - 1281	80	EX - 3018	79
CP - 749K	100	CTR32	128	DTS633	129	EX - 1283	80	EX - 3030	79
CP - 7729	98	CTR33	128	DTS638	129	EX - 1284	80	EX - 3150	72
CP - 772H	101	CTR34	128	DTY27	129	EX - 1285	80	EX - 3150/1	72
CP - 772H - 6	101	CTR36	128	DTY28	129	EX - 1287	80	EX - 366	195
CP - 7733	98	CTR38	128	DTY30	129	EX - 1292A	79	EX - 4660 - A	80
CP - 7733 - 2	99	CTR40	128	DTY32	129	EX - 1292AA	79	EX - 511	71
CP - 7748	99	CTR41	128	DTY33	129	EX - 1292B	79	EX - 513	71
CP - 7748 - 2	99	CU914 - 18X060	105	DTY38	129	EX - 1292E	79	EX - 515	71
CP - 7749	99	CW1 - 50	265	DUSG1	182	EX - 1292N	79	EX - 54 - 920 - 1	190
CP - 7749 - 2	99	CWW060	63	DWS5020	113	EX - 1292R	79	EX - 54 - 920 - 3	190
CP - 7759Q	99	CWW060E	63	EA - 08903	108	EX - 1293N	79	EX - 54 - 920 - 6	192
CP - 7759Q - 2	99	CWW074	63	EA - 09493	108	EX - 1296B	68	EX - 565	195
CP - 7763	100	CWW075	63	EA - 10467	107	EX - 1296C	68	EX - 570N	79
CP - 7763 - 6	100	CWW075E	63	EA - 15334	266	EX - 1296E	68	EX - 570W	79
CP - 7782 - 6	101	CWW150	62	EA - 15336	266	EX - 1296E - 13	68	EX - 5905	70
CP - 7830Q	98	CWW150E	62	EA - 15338	266	EX - 1296F	68	EX - 6047	77
CP - 785	36	CWWAWN	62	EA - 15339	266	EX - 1296F - 25	68	EX - 609	85
CP - 785H	36	CWWEN	62	EA - 30452	266	EX - 1296F - 90	68	EX - 609LB	80
CP - 789R - 42	36	CWWFN	62	EA - 33886	265	EX - 1296G	69	EX - 666	195
CP - 7975P - 6	101	CWWIAW	62	EA - 33894	265	EX - 1296Z1	77	EX - 666K	195
CP - 860	101	CWWLH	62	EA - 43513	265	EX - 1298C	78	EX - 670	70
CP - 871	36	CWWMCN	62	EA - 66476	268	EX - 1298C - 13	78	EX - 670	72
CP - 873	36	CWWTN	62	EA - 66479	268	EX - 1298C - 30	78	EX - 670P	71
CP - 873K	36	D123	160	EA - 66488	268	EX - 1298E	78	EX - 670P	72
CP - 875	101	D - 13R	162	EA - 90011	266	EX - 1300	71	EX - 670R	70
CP - 879	101	D - 15R	162	EA - 90012	265	EX - 1302	71	EX - 670W	70
CPSO31	129	D - 15R - 38	162	EA - 90015	265	EX - 1312	83	EX - 672	69
CPSO33	129	D - 17R	162	EAA0304G15A	205	EX - 1360	84	EX - 678	69
CPSO38	129	D1F100HA	46	EAA0304G20A	214	EX - 1365	84	EX - 679	69
CPY17	128	D - 6C	162	EAC0078G50A	213	EX - 1375	80	EX - 683A	69
CPY18	128	D - 7C	162	EAGLE - II	114	EX - 1407	83	EX - 685	80
CPY19	128	D - 7CR	162	EB1C	235	EX - 1407	71	EX - 700	76
CPY20	128	D - 7CRL	162	EBJ100GC	166	EX - 1407 - 180	83	EX - 777 - BO	82
CPY21	128	DAC1A08	182	EC410419	198	EX - 1407 - 90	83	EX - 789 - O	82
CPY22	128	DEX - 60040	109	EHL - 32	114	EX - 1410	83	EX - 8800	74
CPY23	128	DEX - 60110	109	EN010	56	EX - 1410 - 180	83	EX - 8845	74
CPY24	128	DEX - 60300	109	EN015	56	EX - 1410 - 90	83	EX - 920	190
CPY25	128	DEX - 60310	109	EN020	56	EX - 1412	83	EX - 922	192
CPY26	128	DEX - 70040	109	EN025	56	EX - 1412 - 180	83	EX - 922H - 1	159
CPY27	128	DEX - 70060	109	EN030	56	EX - 1412 - 90	83	EX - 922H - 10	159
CPY28	128	DEX - 70100	109	EN035	56	EX - 1414	83	EX - 922H - 15	159
CPY29	128	DEX - 71120	109	EN040	56	EX - 1414 - 180	83	EX - 922H - 20	159
CPY30	128	DEX - 71130	109	EN045	56	EX - 1414 - 90	83	EX - 922H - 3	159
CPY31	128	DEX - 71180	109	EN050	56	EX - 144 - 0290	82	EX - 922H - 6	159
CPY32	128	DEX - 71220	109	EN055	56	EX - 146 - 6779	82	EX - 922H - 9	159
CPY33	128	D - FB - P9933 - 46	258	EN060	56	EX - 1500L	81	EX - 923	190
CPY34	128	D - FB - R1733 - 87	258	EP1010 - BLACK	254	EX - 1501	81	EX - 923 - 10	190
CPY35	128	DH73040	109	EP1010 - CLEAR	254	EX - 1502	81	EX - 923 - 12	190
CPY36	128	DH73110	109	EP - 15	249	EX - 1503	81	EX - 923 - 20	190
CPY38	128	DP600	227	EP - 9	249	EX - 1504	81	EX - 923 - 25	190
CPY40	128	DPP - 600	135	ES - 300	194	EX - 1504L	81	EX - 924	190
CPY41	128	DPP - 700	135	ES - 301	194	EX - 1506	81	EX - 924 - 1	190
CPY46	128	DPP - 900	135	ES - 305	194	EX - 1506L	81	EX - 924 - 10	190
CS1	218	DS - 1	83	ES - 306	194	EX - 1510	81	EX - 924 - 12	190
CS5	219	DS - 385	71	EX - 1016	80	EX - 1512	81	EX - 924 - 15	190
CT020	57	DSK - 458 - 24	111	EX - 1017	80	EX - 1522	80	EX - 924 - 20	192
CT030	57	DSK - 458 - 24R	111	EX - 1018L	80	EX - 1525	80	EX - 924 - 3	190
CT040	57	DSK - 738 - 16	111	EX - 1019	80	EX - 1587	198	EX - 924 - 6	190
CT060	57	DSK - 738 - 24	111	EX - 1021	80	EX - 1587C	198	EX - 980FT	189
CT080	57	DTLRR19	129	EX - 116V	79	EX - 1616	85	EX - 990	80
CT100	57	DTLRR32	129	EX - 117 - 0764	82	EX - 1800PH	189	EX - AD - 1	80
CT120	57	DTLRR33	129	EX - 1200K	80	EX - 20015	78	EXB - 222	82
CT140	57	DTLRSG32	129	EX - 1200K - 2	80	EX - 2002	78	EXC - 10	71
CTR17	128	DTLRSG33	129	EX - 1220	186	EX - 20025	78	EXC - 100	82
CTR18	128	DTLRY19	129	EX - 1223R	78	EX - 2003	78	EXC - 200	82
CTR19	128	DTLRY32	129	EX - 1230	185	EX - 2004	78	EX - CH - 1	69
CTR20	128	DTLRY33	129	EX - 1235	182	EX - 2005	78	EXD - 7103EC	82
CTR21	128	DTR27	129	EX - 1240	185	EX - 2006	78	EXG - 4985VC	82
CTR22	128	DTR28	129	EX - 1255	189	EX - 2007	78	EXG - 8018VC	82
CTR23	128	DTR30	129	EX - 1255MC	189	EX - 2008	78	EXG - 8019VC	82
CTR24	128	DTR32	129	EX - 1265	74	EX - 2009	78	EXH - 4000	73
CTR26	128	DTR33	129	EX - 1268	74	EX - 2010	78	EXH - 4000/1	73
CTR27	128	DTR38	129	EX - 1270	74	EX - 201075	78	EXJ - 264 - 8214	73



Code	Page	Code	Page	Code	Page	Code	Page	Code	Page
EXJ - 4002	72	FN070	56	H - 077188B	123	HK15	219	IR - 2135 - 425	95
EXJ - 40025	72	FN075	56	H - 082651	103	HK380AN	59	IR - 2135QTI - 2MX	89
EXJ - 4003	72	FN080	56	H - 2125	82	HK380BK	59	IR - 2135QTIMAX	89
EXJ - 40035	72	FP - 134	76	H - 2126	82	HK380BL	59	IR - 2135TI - 2MAX	89
EXJ - 4004	72	FP - 135	76	H - 2127	82	HK380CH	59	IR - 2135TIMAX	89
EXJ - 40045	73	FP - 136	76	H - 2225	82	HK380M1	59	IR - 2135TI - P32	95
EXJ - 4004 - 74	72	FP - 137	76	H - 2227	82	HK380OR	59	IR - 2135 - TK2	95
EXJ - 4005	73	FP - 138	76	H - 2245	82	HK380RD	59	IR - 2145 - P32	95
EXJ - 4006	73	FP - 139	76	H - 2246	82	HK380WH	59	IR - 2145QIMAX	90
EXJ - 4006 - 74	72	FP - 140	76	H - 2247	82	HK380YE	59	IR - 2145QIMAX - 3	90
EXJ - 4007	73	FP - 142	76	H - 2755 - L	74	HN110543	208	IR - 2145QIMAX - 6	90
EXJ - 40075	73	FP - 143	76	H300532P	182	HN61072	208	IR - 2190DTI - 6	90
EXJ - 4008 - 74	72	FP - 144	76	H310532P	188	HPN85T	38	IR - 2190TI - 6	90
EXJ - 4009	73	FP - 145	76	H3610	59	HPN95T	38	IR - 231B - THK1	95
EXJ - 4012	73	FP - 146	76	H361005	59	HR - 1250	158	IR - 231HA	89
EXJ - 4018	73	FRU1 - MP	20	H361010	59	HR - 12RONLY	158	IR - 231HA - 2	89
EXJ - 4020	73	FRU1 - P	20	H361015	59	HR - 12STOP	158	IR - 231HA - P32	95
EXJ - 4021	73	FRU2 - MP	20	H361020	59	HR - 3850	158	IR - 231 - TK2	95
EXJ - 4024	73	FRU2 - P	20	H361025	59	HR - 38RONLY	158	IR - 244 - BOOT	95
EXJ - 4026	73	FTS21C	234	H361030	59	HR - 38STOP	158	IR - 261	89
EXJ - 4036	73	FWC22C	234	H361035	59	HR - ECL40	35	IR - 261 - 3	89
EXJ - 650	72	G - 170S	79	H361040	59	HYDOIL - ARC	238	IR - 261 - 6	89
EXJ - 651	73	GA - 150	187	H361045	59	I - 430 - 6	188	IR - 261 - TK2	95
EXJ - 652	73	GA - 255S	189	H361050	59	I - 450 - 6	182	IR - 281 - TK1	95
EXJ - 653	72	GA - 274	186	H361055	59	I7010	57	IR - 285B	90
EXJ - 654	72	GC1C	235	H380	59	I7020	57	IR - 285B - 6	90
EXJ - 655	72	GP - 1760	161	H380AN	59	I7025	57	IR - 285B - S6	90
EXJ - 657	72	GPLHD - LG	260	H380BK	59	I7030	57	IR - 285B - TK1	95
EXJ - 659	72	GPLHD - MD	260	H380BL	59	I7035	57	IR - 285 - P32	95
EXJ - 690	73	GPLHD - XL	260	H380CH	59	I7040	57	IR - 301	92
EXJ - 690B	73	GNPB - 2XL	260	H380OR	59	I7050	57	IR - 307A	92
EXJ - 690B3A	73	GNPB - LG	260	H380RD	59	I7060	57	IR - 308A	92
EXJ - 691	73	GNPB - MD	260	H380WH	59	I7080	57	IR - 308BK	92
EXJ - 691B	73	GNPB - XL	260	H380YE	59	I7100	57	IR - 3128K	93
EXJ - 692	73	GNPHD - LG	261	H - 41	71	I7120	57	IR - 313A	93
EXJ - 694	73	GNPHD - MD	261	H - 5265	196	I7140	57	IR - 314A	94
EXJ - 695	73	GNPHD - XL	261	H - 543C	75	I7160	57	IR - 317A	93
EXJ - 697	73	GPX3 - LG	260	H - 816	73	IAW005	54	IR - 318A	94
EX - LN10	70	GPX3 - MD	260	HA106871	205	IAW010	54	IR - 319A	93
EXLT - 03	85	GPX3 - XL	260	HA137 - 86 - 2	205	IAW015	54	IR - 326	96
EXM - 165	69	GT - 12100	154	HA2408318	205	IAW020	54	IR - 327	36
EXM - 272	69	GT - 12880	154	HA67715	205	IAW025	54	IR - 327LS	36
EXMR - 800 - 925	82	GT - 12913B	147	HA714100	205	IAW030	54	IR - 3445	93
EXMR - 850 - 8	82	GT - 12914B	147	HB - 2408318	204	IAW035	54	IR - 4152 - HL	93
EXMR - 890 - 10	82	GT - 12916B	147	HB - 3008225	211	IAW040	54	IR - 429	96
EXMR - 890 - 6	82	GT - 12917B	147	HB - 3309048	214	IAW045	54	IR - 50A	236
EXMR - 890 - 8	82	GT - 12919B	147	HB - 3310678	213	IAW050	54	IR - 7803RAKC	96
EXR - 520	74	GT - 3531	167	HB - 3312320	216	IAW055	54	IR - 7807R	96
EXR - 521	82	GT - 3531 - A9	167	HB - 3317259	213	IAW060	54	IR - BC10	90
EXR - 625	74	GT - 3531 - B1	167	HB - 4024181	212	IN - 20	192	IR - CG - 2705	95
EXR - 626	74	GT - 3531 - B12	167	HD351	34	IP - HTPOLY - 12	113	IR - GL - 1	261
EXR - 764R	82	GT - 3531 - B13	167	HE - 200	81	IP - HTPOLY - 15	113	IR - GXL - 1	261
FBS - 50100	107	GT - 432005	167	HE - 201	81	IP - POLY - 12	113	IR - N192	91
FBS - 50170	107	GT - 4532	167	HE - 202	81	IP - POLY - 15	113	IR - R000A2 - 228	96
FE - 300 - 11	82	GT - ABB01	151	HE - 204	81	IR - 100 - 1 - LB	96	IR - R1A - 159	95
FE - 300 - 36	82	GT - BB06L	145	HE - 351	81	IR - 104B	89	IR - R3130 - K2	91
FE - 300 - 5	82	GT - BB09L	145	HE - 352	81	IR - 105 - D2	91	IR - W150 - KL1	91
FE - 300 - 7	82	GT - G412000	164	HE - 369	81	IR - 105 - L2	91	IR - W360 - BOOT	95
FE - 300 - 9	82	GT - G412001	164	HE - 370	81	IR - 105 - LBK1	236	IR - W7150 - K1	91
FMC - 1016845	219	GT - G413000	164	HE - 391	81	IR - 107XPA	92	IR - W7150 - K2	91
FMC - 7007631	219	GT - G420225	167	HE - 392	81	IR - 1105MAX - D3	92	IR - W7250 - K1	91
FMC87084	213	GT - G420300	164	HE - 393	81	IR - 115K	94	J132C	238
FMC - 90667	219	GT - G420302	164	HE - 394	81	IR - 115 - LBK1	236	JL106HZ	64
FN005	56	GT - G420303	167	HE - 395	81	IR - 117	94	JL106VT	64
FN010	56	GT - G422500	164	HE - 396	81	IR - 117K	94	JL108HZ	64
FN015	56	GT - G432020	164	HE - 4430	81	IR - 1207MAX - D3	92	JVT	223
FN020	56	GT - G471105	222	HFZ12100YW3	160	IR - 1207MAX - D4	92	K - 10	115
FN025	56	GT - GB51	147	HFZ12250YW	160	IR - 1215 - 330	95	K - 2	115
FN030	56	GT - GB5Z	145	HFZ1225YW3	160	IR - 1215 - K35	95	K - 21	35
FN035	56	GT - GB5ZA	145	HFZ1250YW3	160	IR - 121K6	94	K - 24A	109
FN040	56	GT - GBBH - 01	147	HFZ14250YW	160	IR - 125	94	K - 30	115
FN045	56	GT - J1	154	HFZ38250YW	160	IR - 2115QTIMAX	89	K - 533	107
FN050	56	GT - Y420500	167	HFZP1425YW2	160	IR - 2115TIMAX	89	K - 534	107
FN055	56	GT - Y471147	222	HFZP1450YW2	160	IR - 2115TI - P32	95	K - 535	107
FN060	56	GX12 - 25	231	HFZP3825YW2	160	IR - 212 - BOOT	95	K - 55D	35
FN065	56	H - 076188B	123	HFZP3850YW2	160	IR - 2131 - TK2	95	K - 55MB	109



Code	Page	Code	Page	Code	Page	Code	Page	Code	Page
K - 56	35	LT1010	56	MC100	55	MI297 - 50	267	N - 1055	186
K - 632	107	LT1015	56	MC100 - 50	55	MI305 - 50	269	N - 1147	78
KB6854	217	LT1020	56	MC100N	55	MI308 - 25	269	N - 1199	198
KD - 33580	130	LT1025	56	MC125	55	MI315 - 100	267	N - 1200	198
KD - 33584	130	LT1030	56	MC125 - 50	55	MI325 - 100	267	N - 1510	80
KLD - 32	235	LT1035	56	MC125N	55	MI335 - 100	267	N - 1600CC	78
KX - 311	30	LT1040	56	MC150	55	MI37 - 25	267	N - 1910	80
KX - 331	30	LT1050	56	MC150 - 50	55	MI397 - 50	267	N238 - 10	159
KX - 361	30	LT1060	56	MC150N	55	MIC - 2	200	N238 - 30	159
KX - 362	30	LTP - 100	135	MC175	55	MIC - 2WB	201	N2 - HKC - 24	159
KX - 363	30	LTP - 150	135	MC175N	55	MIC - 3	200	N2 - HKC - 50	159
KX - 365	30	LTP - 200	135	MC200	55	MIC - 4	200	OKU - PR - 9	249
KX - 37	29	LTP - 60	135	MC200N	55	MIC - 5	200	OPK23	227
KX - 370	30	M100	116	MC225	55	MICH - C1HT - 100	84	P025	53
KX - 375	29	M1518 - 24W	116	MC225N	55	MIC - OTR	201	P025 - 100	53
KX - 376	29	M1721 - 24W	116	MC250	55	MIC - ROLLER	201	P025S	53
KX - 378	29	M175556	216	MC250N	55	MIL - 1805	161	P050	53
KX - 381	29	M1820	116	MC275	55	MIL - 1807	161	P050 - 100	53
KX - 382	29	M1R50H	46	MC275N	55	MIL - 1809	161	P050S	53
KX - 386	29	M2424	116	MC300	55	MIL - 1813	161	P075	53
KX - 387	29	M2519H	116	MC300N	55	MIL - 1815	161	P075 - 100	53
KX - 388	29	M2621H	116	MC325N	55	MIL - 1817	162	P075S	53
KX - 470	29	M2626H	116	MC350N	55	MIL - 1818	162	P - 083071	103
KX - 471	29	M2732/32W	116	MC375N	55	MIL - 1819	162	P100	53
KX - 472	29	M2828	116	MC400N	55	MIL - 1820	162	P100 - 100	53
KX - 473	29	M2836H	117	MD	226	MIL - 1833	161	P1004	118
KX - 474	29	M3015H	116	M - FB - P9933 - 72	255	MIL - 1835	161	P100S	53
KX - 490F	30	M3132H	116	M - FB - P9933 - 73	255	MIL - 1837	161	P125	53
KX - 491F	30	M3336/32W	116	M - FB - P9943 - 94	255	MIL - 1838	161	P125 - 100	53
KX - 507F	229	M3536	116	MFG - P9943 - 28D	259	MIL - 1839	161	P125S	53
KX - 508F	30	M3541	116	MG - 11100	248	MIL - 1840	161	P15	72
KX - 5101	30	M3624	116	MG - 111000	248	MIL - 1855	161	P150	53
KX - 5102	30	M3638	116	MG - 111111	248	MIL - 1857	161	P150 - 100	53
KX - 5103	30	M3842/32W	116	MG - 11150	248	MIL - 1858	161	P150S	53
KX - 511F	30	M4220H	116	MG - 112000	248	MIL - 1859	161	P175	53
KX - 928	33	M4447/32W	116	MG - 1124	248	MIL - 1860	161	P175S	53
KX - 931	33	M45/6	116	MG - 112420	248	MIL - 715	161	P200	53
KX - MX10	29	M45/6/7	116	MG - 15100	248	MIL - 718	161	P200S	53
KX - MX12	29	M4814C	235	MG - 151000	248	MIL - 731	161	P225	53
KX - MX14	29	M4824	116	MG - 15150	248	MIL - 755	161	P225S	53
KX - MX20	29	M4824H	116	MG - 15200	248	MIL - 775	159	P250	53
KX - MX22	29	M4824W	116	MG - 152000	248	MIL - 779	162	P250S	53
KX - MX24	29	M4832E	116	MG - 18100	248	MIL - 787	162	P275	53
KX - MX40	29	M5432W	116	MG - 181000	248	MK41580	109	P275S	53
KX - MX42	29	M6032	116	MG - 18100R	248	MK42810	109	P300	53
KX - MX44	29	M6732W	116	MG - 18150	248	MK42820	109	P300S	53
KX - UP - 45	29	M705C	235	MG - 18200	248	MPB - 314 - 36	64	P325	53
KX - UP - 45P	29	M7232	116	MG - 182000	248	MPB - 319 - 18	64	P400	53
KX - UP - 55	29	M739C	235	MG - 251000	248	MRO2040	35	P43	118
KX - UP - 55P	29	M7532W	116	MG - 251815	248	MRO2080	35	P44	118
L112C	238	M9032W	116	MG - 25200	248	MRO2110	35	P45	118
L - 15	247	M914C	238	MG - 252000	248	MRO2860	35	P450	53
L412C	238	MAG - I	147	MG - 301000	248	MRO2890	35	P48	118
LB106259	204	MAG - II	147	MG - 30200	248	MRO2910	35	P49	118
LB106572	204	MB - 220 - BK	63	MG - 302000	248	MRO2980	35	P500	53
LB66006	204	MB - 220 - BL	63	MG - 303030	248	MRO2990	35	P500 - 5	194
LH025	55	MB - 220 - GR	63	MG - 35100	248	MRO3150	35	P58	118
LH050	55	MB - 220 - GY	63	MG - 351000	248	MR10880	35	P58A	118
LH075	55	MB - 220 - OR	63	MG - 353535	248	MR10910	35	P59	118
LH100	55	MB - 220 - PL	63	MG - 45450	248	MTC	222	P60	159
LH125	55	MB - 220 - RD	63	MG - 45450 - E	248	MTD - 60	226	P600	53
LH150	55	MB - 220 - YL	63	MH26000	109	MTD - 72	226	PAB - F	105
LH175	55	MC025	55	MH26470	109	MTP - 250	135	PAS - 3 - 120	118
LH200	55	MC025 - 50	55	MI17 - 25	267	MTP - 300	135	PAS - 3 - 16 - 12	118
LH225	55	MC025N	55	MI197 - 50	267	MTP - 400	135	PAS - 4 - 120	118
LH250	55	MC050	55	MI20	267	MTP - 500	135	PAS - 4 - 16 - 12	118
LH275	55	MC050 - 50	55	MI200	267	MVN100	116	PAS - 5 - 16	118
LH300	55	MC050N	55	MI215 - 100	267	MVS9001 - 100	116	PATRIOT - MI	114
LR	38	MC075	55	MI225 - 100	267	MW - 40	199	PB - 1	9
LR - EF	37	MC075 - 50	55	MI235 - 100	267	MW - STAND	199	PB - 10	9
LT1005	56	MC075N	55	MI27 - 25	267	N - 10125	71	PB - 11	9



Code	Page	Code	Page	Code	Page	Code	Page	Code	Page
PB - 2	9	PN - 056S	22	PT - 3	11	RC020	57	RU020C	58
PB - 3	9	PN - 058	22	PT - 3B	11	RC030	57	RU025C	58
PB - 4	9	PN - 058+	22	PT - 4	11	RC040	57	RU030C	58
PB - 5	9	PN - 058S	22	PT - 4B	11	RC060	57	RU035C	58
PB - 6	9	PN - 058S+	22	PT - 5	11	RC080	57	RU040C	58
PB - 7	9	PN - 10	20	PT - 6	11	RC120	57	RU045C	58
PB - 8	9	PN - 20	22	PT7	130	RCG - AL	122	RU050C	58
PB - 9	9	PN - 21	22	PT - 7	11	RG2	64	RU055C	58
PB - B	238	PN - 22	22	PT - 8	11	RG - 70	79	RU060C	58
PBN - 3	10	PN - 23	22	PT - 9	11	RGP1	64	RUSK - 8S	109
PBN - 4	10	PN - 24	22	PT - GAUGE	74	RH100	109	RUSX10X1 - 1/4S	109
PBN - 6	10	PN - 25	22	PTL - 1G	230	RH100 - S	110	RWICK - 8X12	113
PBN - 7	10	PN - 3	20	PTLC - 1	230	RH102	109	S1015	118
PBS - 32	229	PN - 4	20	PTLC - 2G	230	RH106 - S	110	S1016	118
PBT - 0	10	PN - 40	22	PTLC - 55G	230	RH107	109	S1017	118
PBT - 1	10	PN - 41	22	PTLC - 5G	230	RH107 - 60	109	S1018	118
PBT - 2	10	PN - 42	22	PTT - 1	12	RH108 - S	110	S1019	118
PBT - 3	10	PN - 5	20	PTV	86	RH109	109	S1021	118
PBT - 4	10	PN - 6	20	PUR - 2	11	RH110 - S	110	S1022A	118
PBT - 5	10	PN - 60+	22	PUR - 3	11	RH111	109	S1023A	118
PBT - 6	10	PN - 7	20	PURF - 1	10	RH112	109	S1025	118
PBT - 7	10	PN - 8	20	PURF - 1T	10	RH114	109	S1028	118
PC - 1	8	PN - 9	20	PURF - 2	10	RH114 - S	110	S1028 - STD	118
PC - 2	8	PP1	118	PURF - 2T	10	RH1150	110	S1030	118
PC - 2J	8	PPC - 16	11	PURF - 3	10	RH116	109	S1040	115
PC - 3	8	PPC - 1G	11	PURF - 3T	10	RH1160	110	S1041	115
PC - 3J	8	PPC - 32	11	PUS - 2	11	RH116 - S	110	S1041/38	115
PC - 4	8	PR1	118	PUS - 3	11	RH118	109	S1043	115
PC - 5	8	PR - 109	8	PUS - 4	11	RH118 - S	110	S1044	115
PCAB - 1	13	PR - 110	8	PUSF - 2	10	RH120	109	S1046	115
PCAB - STARTUP	13	PR - 110B	8	PUSF - 2T	10	RH120 - S	110	S1046D	115
PCC - 1	33	PR - 112	8	PUSF - 3	10	RH122	109	S1047	115
PCC - 2	33	PR - 112B	8	PUSF - 3T	10	RH122 - S	110	S1047XL	115
PCC - 2P	33	PR - 113	8	QRF - 14	37	RH122 - S - 460	113	S1048	115
PCC - 3	33	PR - 114	8	QS3000	64	RH126	109	S1049	115
PCC - 3P	33	PR - 115	8	QUBE4	199	RH129P	109	S1055N	35
PCC - 4	33	PR - 120	8	R105 - 22	114	RH130	36	S - 115 - 20	114
PCC - 5	33	PR - 122	8	R115 - 20	114	RH130 - 170	36	S - 115 - 25	114
PC - P3 - 20	114	PR - 124	8	R115 - 25	114	RH130 - 230	36	S - 166	161
PC - R115 - 20	114	PR - 125	8	R115SB - 25	114	RH150	113	S - 167	161
PC - R4 - 25	114	PR - 126	8	R4 - 20	114	RH151	113	S - 180	118
PC - ULTRA - I	114	PR - 135	8	R4 - 25	114	RH152	113	S - 182	118
PC - ULTRA - II	114	PR - 140	8	R - 520	74	RH154	113	S2P3	114
PC - ULTRA - III	114	PR - 142	8	R600846M	114	RH156	113	S2S16	114
PEP - 22	229	PR - 144	8	R732774	114	RH300	110	S2S8	114
PEP - 8	229	PR - 180	9	R733001	114	RH302	110	S3S16	114
PEP - 8N	229	PR - 182	9	R - 84S5010G	113	RH304	110	S3S8	114
PEP - BK	233	PR - 184	9	R - 98MR1B50 - 16	113	RH306	110	S870	108
PEP - BKN	233	PR - 186	9	RAD - 0	19	RH308	110	S871	108
PEP - BS	233	PRE8001	237	RAD - 104	23	RH505	110	S872	108
PFC - 10ML	11	PRE8153	237	RAD - 110	19	RH507	110	S873	108
PFC - 32	11	PRE8201	237	RAD - 115	19	RH511	110	S874	108
PFC - 8	11	PRI - 1	12	RAD - 116	19	RH551	110	S875	108
PG103	118	PRI - 2	12	RAD - 120	19	RH553	110	S879	108
PG104	118	PRI - 2K	13	RAD - 122	19	RH601	110	S890	108
PHC - DISP	265	PRI - 3	12	RAD - 124	19	RH603	110	S891	108
PHC - SUPER	262	PRI - 3K	13	RAD - 125	19	RH611	110	S892	108
PIV - 9FT	11	PRI - 4	12	RAD - 126	19	RH613	110	S892W	108
PJN	115	PRI - ATV	12	RAD - 128	19	RH619	110	S896	108
PL1	118	PRN - 110	9	RAD - 135	19	RH626	110	S897	108
PLD - 32	235	PRN - 110B	9	RAD - 140	19	RH635	110	S - 903	188
PLD - 32C	235	PRN - 112B	9	RAD - 142	19	RH713	110	S - 917	183
PLOS - 16	12	PRN - 115	9	RAD - 144	19	RP27040080	212	S - 921	183
PLV	80	PRN - 120	9	RAD - 145	19	RP692071	113	S - 923	183
PM - 20002	245	PRN - 122	9	RAD - 146	19	RP692071	114	S - 925	184
PM - 32303	244	PRN - 124	9	RAD - 150	19	RP900250	160	S - 927	184
PMLC - 16	230	PRN - 125	9	RAD - 152	19	RP900250BS	160	S - 928	188
PN - 0	20	PRN - 135	9	RAD - 155	19	RR549 - 38	105	S - 929	187
PN - 050	22	PRN - 140	9	RAD - 156	19	RR914 - 38	105	S - 976	185
PN - 050+	22	PRN - 142	9	RAD - 160	19	RS - 10	21	S999	35
PN - 052	22	PRN - 144	9	RAD - 162	19	RS - 12	21	S999 - BAG	35
PN - 052+	22	PT - 1	11	RAD - 165	19	RS - 32	229	SADHR25C	61
PN - 054	22	PT - 10	11	RAD - 168	19	RTT - 5930467	265	SADHR - COMP	61
PN - 054+	22	PT - 11	11	RAD - 175	19	RU005C	58	SADHR - HOLDER	61
PN - 056	22	PT - 2	11	RAD - 185+	19	RU010C	58	SADHS100C	61
PN - 056+	22	PT - 2B	11	RAD - 1N	19	RU015C	58	SADHS25C	61



Code	Page	Code	Page	Code	Page	Code	Page	Code	Page
SADHS50C	61	T035	118	T45AC	142	TC - 610	151	TI973	130
SATSIM	251	T036	118	T45HD	142	TCB304 - 4	214	TI9800	226
SB20885S	265	T047	118	T46A	142	TCB7591 - 10	214	TIA - TPMS - 13	50
SB - 210 - BK	63	T048	118	T46B	142	TCB7900	204	TL - 132	85
SB - 210 - BL	63	T050N	56	T46C	142	TCR343	210	TL - 133	85
SB - 210 - GR	63	T075N	56	T47A	142	TCR343 - 6	210	TL - 632	85
SB - 210 - GY	63	T095	118	T47B	143	TCW	112	TL - 695	80
SB - 210 - OR	63	T096	118	T47C	143	TCW - 210 - 16	112	TL - LN - 10	80
SB - 210 - PL	63	T100N	56	T48A	139	TCW - 210 - 36	112	TM - 30403	244
SB - 210 - RD	63	T101	201	T51	37	TCW - 210 - 40	112	TM - 30403Y	244
SB - 210 - YL	63	T101A	201	T52	148	TCW - 210 - 60	112	TNDS8005	237
SB3085	217	T102	201	T6A	139	TCW - 310 - 16	112	TNDS8008	237
SB3085RUB	217	T104	201	T950	142	TCW - 310 - 36	112	TNDS8011	237
SB3086	217	T11BH	137	T9A	140	TCW - 315 - 16	112	TNDS8115	237
SB3087	217	T11CH	138	TA - 2200 - 16	111	TCW - 315 - 36	112	TNDS8253	269
SB7075	219	T11D	137	TA - 2200 - 36	111	TCW - 315 - 60	112	TNDS8412	269
SB9800	219	T11DH	138	TA - 2203 - 36	111	TCW - 415 - 16	112	TNT - 100 - 1	155
SD40PHL	225	T11E	137	TA - 2204 - 16	111	TCW - 415 - 36	112	TNT - 200 - BCA	154
SFE - 400 - 10	71	T11EH	138	TA - 2204M - 16	111	TCW - 415 - 60	112	TNT - 100	155
SFE - 400 - 13180	71	T11EH - GRIP	138	TA - 2205 - 36	111	TCW - 615 - 16	112	TNT - 200	155
SFE - 400 - 5	71	T11K	137	TA - 2205M - 36	111	TCW - 615 - 36	112	TNT - 200 - 1	155
SFE - 400 - 7	71	T11KH	138	TA - 2206 - 16	111	TDW - 310 - 16	112	TNT - 200 - M	155
SG7996	217	T11RH	139	TA - 2207 - 36	111	TDW - 410 - 16	112	TPCRADLE	50
SIP	245	T125N	56	TA - 2207M - 36	111	TDW - 410 - 36	112	TPG4J05	184
SLJ10027	166	T131	153	TA - 2208 - 16	111	TDW - 510 - 16	112	TR10	130
SLJ10038	167	T132	153	TA - 2208M - 16	111	TDW - 510 - 36	112	TR1315 - 20W	116
SLJ15027	167	T133	153	TA - 2209 - 36	111	TDW - 610 - 16	112	TR2210H	116
SLJS100	167	T150N	56	TA - 2210 - 16	111	TDW - 610 - 36	112	TR2213E	116
SLJS200	167	T16A	140	TA - 2505 - 36	111	TG11CH	138	TR2213H	116
SLJST - 100	167	T175	265	TA - 2506 - 16	111	TG11D	137	TR25040	47
SLJST - 200	167	T175N	56	TA - 2507 - 36	111	TG11DH	138	TR25306	47
SLP - 5005	115	T19	141	TA - 2508 - 16	111	TG11E	137	TR25985	46
SLP - 9165	37	T19A	141	TA - 2612 - 16	111	TG11EH	138	TR2621E	116
SLP - 9201	115	T1X	140	TA - 2613 - 36	111	TG1C	234	TR2621H	116
SLP - 9202	115	T20	141	TA - 2614 - 16	111	TG337	137	TR2621 - OC	116
SLP - 9211	115	T2000	143	TA - P208 - 16	111	TG35	137	TR5	141
SLP - 9212	115	T2001	143	TA - T350 - 16	111	TG36	137	TR911 - 13W	116
SLP - 9213	115	T2002	143	TA - T418 - 16	111	TG914 - 18X060	105	TROC4	116
SLP - 9214	115	T2005	35	TA - T418 - 36	111	THRG08	223	TROC5XL	116
SLP - 9215	115	T200N	56	TA - T438 - 16	111	TI114	47	TS - 11	246
SLP - 9216	115	T2035	35	TA - T450 - 16	111	TI11400096	214	TS - 12	246
SMR - 1524H	117	T20A	141	TA - T650 - 16	111	TI115	206	TS - 13	246
SMR - 1818H	117	T21F	141	TBYD03	112	TI119	50	TS - 15	246
SMR - 2828H	117	T21HD	141	TBYH1	112	TI1506	233	TS - 16	246
SMR - M1721 - 24W	117	T21R	141	TBYH12	112	TI156	130	TS - 17	246
SMR - M2519H	117	T225N	139	TBYOX2R	112	TI16	33	TS - 19	247
SMR - M2732/32W	117	T23	139	TBYOX3R	112	TI16 - N	33	TS - 21	247
SMR - M3015H	117	T23A	139	TC0066	214	TI181065	206	TS - 23	247
SMR - M3132H	117	T23B	139	TC0343 - 6	210	TI181162	206	TS - 8X15B	247
SMR - M4215H	117	T24B	153	TC108276	205	TI181173	207	TS - 9X17R	247
SMR - M4220H	117	T25	139	TC113125C	211	TI181851	207	TS - 9X20R	247
SMR - M4447/32W	117	T250N	148	TC11400098 - 4	216	TI181855	206	TSC - 8 - 13RY	247
SMR - M4824H	117	T26B	153	TC14024784	207	TI182079	206	TSC - 9 - 16 - 6RY	247
SMR - M4824W	117	T27	139	TC181354	216	TI182961	213	TSC - 9 - 16MC	247
SMR - M4832E	117	T275N	139Δ139	TC181677 - 4	211	TI20011064 - 10	212	TSC - 9 - 18 - 5MCH	247
SMR - M5432W	117	T27A	139	TC181995	207	TI215	245	TSC - 9 - 19 - 6RY	246
SMR - M6732W	117	T2X	141	TC182247 - 4	212	TI24016079	212	TSC - 9 - 22MC	247
SMR - M9032W	117	T300N	56	TC182250	211	TI254341A	213	TSC - 9 - 25MCH	247
SMR - TR2213H	117	T32	140	TC182788	210	TI31	130	TSIT - 11	249
SMR - TR2621AB	117	T325N	56	TC183429	210	TI33	130	TSIT - 9	249
SMR - TR2621H	117	T34B	225	TC183604 - 10	215	TI34	130	TU216 - 84B	113
SN - M22	122	T34RH	139	TC183605	215	TI36	130	TV - 400	77
SP3110	219	T35	137	TC184126 - 4	211	TI38	130	TV - 401	77
SP3590	221	T350N	56	TC184268	211	TI54	34	TV - 416MC	78
SS10	109	T36B	225	TC184327	211	TI6350	233	TV - 542	75
SSG060N	60	T38	141	TC184958 - 4	211	TI851855	206	TV - 544C	75
SST300N	60	T39	141	TC20024335	207	TI95	114	TV - 546E	75
STXM44	239	T400N	56	TC2402	216	TI950	130	TV - 547D	75
SW184389	206	T401T	233	TC247G15A - 10	213	TI951	130	TV - 6008C	70
SW20016433	206	T41	148	TC250309	210	TI952	130	TV - 6010	77
SXL - 1008L	82	T42	148	TC336742 - 4	211	TI956	130	TVCT	46
SXL - 1660 - 50	82	T43A	140	TC435685	209	TI9580	225	TVT	85
T023	118	T45A	142	TC450310	210	TI963	130	TW - 12	115
T025N	56	T45A - 2000K	142	TC600	154	TI9700	225	UP - 3	20



Code	Page	Code	Page	Code	Page
UP - 4 5P	20	VHC805	162	WB463202	208
UP - 6	20	VHC807	162	WB725 - 40	110
UP - 6AP	20	VHC808	162	WH - 45 - 2 - 1/2	73
UP - 8	20	VHC809	162	WICK - 8X15	113
UP - 8P	20	VHC810	162	WRT200	44
UVEXB	254	VHC815	162	WRT300POBD	44
UWT1200HP	130	VHC817	162	WRT300PSDC	44
V - 1002789	117	VHC818	162	WRT300SD	44
V - 1002809	117	VHC83	162	WRT4001PC	46
V - 1002819	117	VHC83B	162	WRT400CAB	46
V - 1002829	117	VHC84	162	WRT400NAT	44
V - 1002849	117	VHC84B	162	WRT400POBDC	46
V - 1002859	117	VHC85	162	WRT400SD	44
V - 1002869	117	VHC90	160	WRT400SUL1	44
V - 1002889	117	VHC91	160	WRT400SUL2	44
V - 1002919	117	VHC92	160	WRT400SUL3	44
V - 1002929	117	VHJ6100	194	WRT500	44
VALVECAPPER	85	VHJ6105	80	WRT500MK	46
VB40141	220	VHJ6111	189	WRT500SUL1	44
VC8G - 100	84	VHP664	184	WRT500SUL2	44
VC8G - 1000BK	84	VHP665	185	WRT500SUL3	44
VH3216	85	VHP665M	185	WRTCNK001	50
VH54HT - 1	83	VHP668	186	WRTCNK0010	50
VH592	70	VHP668M	187	WRTCNK0015	50
VH595	69	VHP669	187	WRTCNK0020	50
VH595	69	VHP698	193	WRTCNK0025	50
VH598	70	VHP698L	193	WRTCNK0030	50
VH601	81	VHP698RK	195	WRTCNK0035	50
VH602	81	VS - 542	75	WRTCNK0040	50
VH603	81	VS - 545 - B	75	WRTEZS - STK10	46
VH607	85	VS - 545 - C	75	WRTEZS - STK34	46
VH608	85	VS - 545 - D	75	WRTEZS - STK35	46
VH65558	80	VS - 546 - D	75	WRT - MAGNET	46
VH65658	80	VS - 546 - E	75	WRTMT103 - 01	47
VH660	187	VS - 546 - G	75	WRTMT103 - 02	47
VH661	183	VS - 552	76	WRTMT103 - 03	47
VH662	184	VS - 553	76	WRTMT103 - 06	47
VH663	183	VS - 553 - C	76	WRTMT103 - 10	46
VH664	184	VS - 553 - E	76	WRTMT104	47
VH665	185	VS - 554 - D	76	WRTOBD002	46
VH667	191	VS - 555 - D	76	WRTPAD1	44
VH668	186	VS - 555 - E	76	WRTPADSUL1	44
VH668 - R180	186	VS - 572 - F19	68	WRTPADSUL2	44
VH669	187	VS - 902 - CR	74	WRTTRST50	46
VH670	85	VS - 902K	78	WRTTRKIT6	46
VH673	85	VS - 902WP	78	Z - 04100US419	215
VH674	85	VS - 938F	78		
VH675	80	VS - 943 - R	78		
VH678	85	VS - 944F	78		
VH679	85	VS - 946 - R	71		
VH680	85	VS - 962C	78		
VH690	196	VS - 965	43		
VH690RK	197	VSPRAY4	269		
VH690W	197	VSPRAYPRF01	269		
VH691	197	VSW - 916	85		
VH692	197	VV - 1004502	109		
VH693	197	VV - 1721/24CAB	117		
VH694	196	VV - 2215H	117		
VH695	196	VV - 2621H	117		
VH696	193	VV - 2621HGB	117		
VH696RK	195	VV - 2815H	17		
VH698	193	VV - 4824FAB	117		
VH698L	193	WA4525	77		
VH698RK	195	WA4525 - EXT	77		
VH824	79	WB1061572	208		
VH936 - 500	70	WB106822	208		
VH936A	70	WB110542	208		
VH936B	70	WB112373	208		
VHB9A	73	WB144026	208		
VHC15	161	WB1753531	208		
VHC27	161	WB1753921	208		
VHC28	161	WB2251 - 40	110		
VHC50	199	WB2252 - 40	110		
VHC75	159	WB2253 - 40	110		
VHC77	159	WB2255 - 40	110		
VHC78	159	WB308171	208		
VHC803	162	WB - 310000	208		

**A**

A & B Compound.....105
AC HYDRAULIC.....165
Air Bags.....116 – 118
Air Blasters.....144 – 147
Air Chucks:
.....*Ball Foot*.....196, 197
.....*Check Chucks*.....196
.....*Dual Foot*.....193, 194
.....*Euro Style*.....198
.....*Large Bore*.....80, 195
.....*Repair Kits*.....194, 195, 197
.....*Sliding Sleeve*.....196
.....*Specialty*.....194
Air Gauges:
.....*Air Liquid*.....185 – 188
.....*Checking Station*.....191
.....*Dial Face*.....185, 186, 187
.....*Digital*.....182
.....*Dual Foot*.....184, 185, 186
.....*Large Bore*.....182, 189
.....*Low Pressure*.....183
.....*Master Gauge*.....191
.....*Passenger*.....182, 183
.....*Pencil*.....183
.....*Recalibratable*.....185
.....*Truck*.....182, 184 – 186
Air Hose:
.....*Clamps*.....159
.....*Flexzilla*.....160
.....*Poly Coil*.....158
.....*Reels*.....158
.....*Reinforced*.....158
.....*Rubber*.....158
.....*Whips*.....159
Air Hose Fittings.....160
Air Inflation Systems.....199
Air Inflators:
.....*Dial Face*.....188, 189
.....*Digital*.....182
.....*Eurodair*.....188
.....*Large Bore*.....189, 190
.....*Standard*.....190, 192
Air Lift Bags.....169
Air Line Fittings:
.....*ARO Style*.....159
.....*Industrial Style*.....161
.....*Lincoln Style*.....160
.....*Tru-Flate Style*.....161
Air Line Filtration.....224, 225, 226
Air Liquid Core Ejector.....76
Air Tool Oil.....236
Air Tools:
.....*Ratchets, 1/4"*.....91
.....*Ratchets, 3/8"*.....92, 98
.....*Ratchets, 1/2"*.....92
.....*Cut Off Tools*.....96
.....*Drills*.....36, 96
.....*Grease Guns*.....96
.....*Grinders*.....92, 93, 101

Air Tools: (cont'd)

.....*Hammers*.....94, 101
.....*Needle Scalers*.....94
.....*Polishers*.....93, 94
.....*Sanders*.....93, 99
.....*Saws*.....96
Air/Hydraulic Jacks.....164 – 168
AIR-FLEXX.....83
Alignment Shims.....123 – 126
Aluminum Oxide Stones.....108
Arbors.....115
ATEQ.....44, 51
Awls.....34

B

Balancing Compound.....135
Ball Joint Press Kit.....226
BARTEC.....44, 46, 47, 48, 50
Bead Bazookas.....145 – 147
Bead Breakers:
.....*Chemical*.....229, 237
.....*Boa Constrictor System*.....148
.....*Hydraulic*.....149 - 151
.....*Manual*.....148, 151
.....*Parts & Accessories*.....152, 153
.....*Pneumatic*.....151
.....*Slide Bars*.....148
.....*Upgrade Kits*.....152
Bead Butter.....232
Bead Hammer Handles.....137, 138
Bead Hammer Heads.....139
Bead Hammers.....137
Bead Holders.....143, 205
Bead Hooks.....223
Bead Sealer.....229
Bead Seaters:
.....*Bazooka*.....145 – 147
.....*Cheetah*.....144, 145, 147
.....*Donuts*.....144
.....*Parts & Accessories*.....147
.....*Pump Rings*.....147
Bearing / Rotor Puller System.....226
Blow Guns.....161
Bottle Jacks.....164, 165
Brake Cleaner.....235, 237
Brake Lathe Parts.....216 – 222
Bristle Discs.....268, 269
Budd Wheel Hardware.....121
Buffer Adaptors.....115
Buffer Chucks.....37
Buffing Blades.....114
Buffing Cups.....110
Buffing Wheels.....36, 110

C

Calcium Pumps.....155
Cam Nuts.....127
Camber Arms.....127
Camber Bolts.....126
Carbide Burrs.....107
Carbide Cutters.....33

Cement:

.....*Cold Vulcanizing*.....11, 22, 30
.....*Hot Vulcanizing*.....107
Cement Brushes & Accessories.....107
Cement Cans.....107
Chalk.....244, 245
Chalk Holders.....245, 246
CHECKPOINT.....127 – 129
Cheetah Bead Blasters.....144, 145, 147
CHICAGO PNEUMATIC.....36, 98 – 103
Chrome Wheel Covers.....122
COUNTERACT.....87, 135
Cribbing.....170, 171
Cushion Gum.....105
Cutoff Wheels.....265

D

Dayton Wheel Hardware.....121, 122
Degreaser.....234, 235, 237
Demount Tools.....154, 155
DILL Redi-Sensors.....41, 42
Disc Adaptors.....268
Dispatch Numbers.....257
Dry Balancing Powder.....135
Duckheads.....207, 210
Dunk Tanks.....38, 39
Durometers.....113

E

Ear Muffs.....255
Ear Plugs.....255
Encapsulated Brushes.....108
Envelope Checking Station.....106
Envelope Lubricant.....106
Envelope Poly.....113
Envelopes.....106
Euro Paste.....229
Extruder Cleaning Compound.....105
Extruder Rubber.....105
Extruders.....118
EZ Sensors.....41, 45

F

Face Shield.....255
Flange Ring Puller.....224
Flap Discs.....265, 268
Flex Shaft Buffers.....115
FLEXZILLA.....160
Floater Gum.....105
Floor Jacks.....164 - 168
Floor Mats.....256, 257
Forklift Tire Press.....225

G

Gaither.....145 – 148, 164, 167
Gauge Checking Stations.....191
Glass Cleaner.....236
Gloves:
.....*Foam Dipped Nylon*.....260
.....*Impact/Mechanic's*.....261
.....*Nitrile*.....260, 261
.....*Retread*.....261
.....*Vinyl*.....260



Golden Tools.....154, 155
 Gougers.....108
 Graphite Mounting Lubricant.....231, 232
 Grinding Discs.....269

H

Hand Cleaner.....262 – 265
 Hand Rasps.....33, 34
 HAWEKA.....130 – 134
 Heat Pads.....116, 117, 118
 Hose Clamps.....159
 Hose Reels.....158
 Hydraulic Bead Breakers.....149 – 151, 156
 Hydraulic Oil.....238
 Hydraulic Pumps.....152
 Hydraulic Rams.....151

I

Ice Stud Insertion Tools.....249 – 252
 Ice Studs.....246, 257
 Impact Wrenches:
Accessories.....95, 103
Cordless Battery.....91
Cordless Charger.....90
Cordless, 3/8".....91
Cordless, 1/2".....91
Parts.....95, 103
Pneumatic, 1/4".....89, 98
Pneumatic, 3/8".....89, 98
Pneumatic, 1/2".....89, 98 – 100
Pneumatic, 3/4".....89, 90, 100, 101
Pneumatic, 1".....90, 101
Tune-up Kits.....95, 103
 INGERSOLL RAND.....36, 89 – 97, 236
 Inspection Tools.....34

J

Jack Plates.....170, 171
 Jack Stands.....170
 Jacking Beams.....225
 Jacks.....164, 165

K

KENTOOL.....137 – 144
 Key Tags.....257
 Knife Heaters.....109
 Knives.....109

L

Leak Detectors.....38, 39, 235
 Lights.....35
 Liquid Tire Lubricant.....230
 Lock Ring Tools.....139, 143
 Lubricant Brushes.....233
 Lubricant Buckets.....206

M

MAGNUM.....120, 135
 Manual Bead Breakers.....148, 151
 Manual Tire Changers.....205
 Master Gauges.....191
 Maxi-Grip.....248
 Mill Blades.....109
 Mold Lubricant.....105

MONARCH.....116
 Mount-Demount Bars.....142
 Mount-Demount Tools.....154, 155
 Mushroom Stones.....108

N

Nitrogen Inflation.....159

O

Oil:
Air Tool.....236
Hydraulic.....238
Penetrating.....237, 238
 OTR Jacks.....164, 166, 167
 OTR Tire Mounting Compound.....232

P

Paintstick Holders.....245, 246
 Paintsticks.....244, 245
 Parts Bags.....256
 Parts Cleaning Brush.....266
 Pencil Stones.....108
 Penetrating Oil.....237, 238
 Personal Protection:
Face Shields.....255
Foam Dipped /Nylon Gloves.....260
Hearing Protection.....255
Impact/Mechanic's Gloves.....261
Nitrile Gloves.....260
Retread Gloves.....261
Safety Glasses.....254
Vinyl Gloves.....260
 Pistol Grip Tools.....33
 Pliers.....35
 Pneumatic Bead Breakers.....151
 Pressure Equalizers.....86
 Probes.....34
 Pumps:
Calcium.....155
Hydraulic.....152

Q

Quick Change Adaptors.....115
 Quick Change Chucks.....37
 Quick Nuts.....132, 133

R

Redi-Sensors.....41, 42
 Repair Brushes.....34
 Repair Rubber.....105
 Replacement Handles.....137
 Replacement Needles, Insert Tools.....33
 Retread Couplers & Adaptors.....115
 Retread Envelopes.....106
 Retread Poly.....113
 Rim Centering Guides.....122
 Rim Kote.....230
 Rim Protectors.....121, 122
 Roloc (Wheel Nut Locks).....129
 Roloc (3M Discs).....266, 267
 Rope Rubber.....105
 Rotary Gougers.....108
 Rubber Cutting Knives.....109
 Rubber Solvent.....11, 23, 30

RubberHog:

.....Balls.....110
Buzzout Wheels.....110
Cones.....110
Discs.....110
Flared Contour Wheels.....36, 109
Poly Plugs.....113

S

Safety Cages.....200, 201
 Safety Glasses.....254
 Scan Tools, TPMS.....44
 SCHRADER EZ Sensors.....41, 45
 Scissors.....109
 Scrapers.....34
 Seat Covers.....256
 Serpent Tool.....143, 144
 Service Reminder Printers.....258
 Shop Equipment, Misc.....222 – 227
 Side Cutters.....35
 Silicone lubricant.....105
 Silicone Spray.....238
 Siping.....223
 Skid Bead Breaker.....229
 Skirt Nuts.....122
 Skiving Brushes.....108
 Slide Bars.....148
 Sling, OTR Tire.....223
 Sockets:
1/2" Drive.....173 – 175
3/4" Drive.....176 – 177
1" Drive.....177 – 180
#5 Spline.....180
 Spare Tire Removal Set.....224
 Spoon Bars.....140, 141
 Spring Compressors.....127
 Strut Spring Compressor.....225
 Staplers.....113
 Static Cling Labels.....258
 Stitchers.....35
 Strip-it Discs.....265
 Studs:
Tire.....246, 247
Insertion Tools.....249 – 252
Screw-in.....248
 Surface Conditioning Discs.....266 – 268

T

Tack Bands and Discs.....112
 Texturizing Brushes.....108
 T-Handle Tools.....33
 Thermopress.....116
 Tire Bags.....259
 Tire Buffers, Hi Speed.....36
 Tire Buffers, Low Speed.....36, 115
 Tire Carts.....222
 Tire Chalk.....244, 245
 Tire Chalk Holders.....245, 246
 Tire Changer Accessories and Parts:
Air Gauges.....206
Bead Breaker Parts.....207, 208
Bead Lifting Tools.....215, 216



Tire Changer Accessories and Parts:
(cont'd)

- Duckheads.....207, 210
- Hold Down Cones.....207
- Inflator Hoses.....206, 207
- Jaw Kits and Parts.....210 – 212
- Demount Head Parts.....212 – 215
- Pads.....208, 209, 214
- Seal Kits.....208
- Switches.....208

Tire Changer, Manual.....205

Tire Cleaner.....234

Tire Disposal Dolly.....226

Tire Hammers.....140

Tire Irons.....139 – 144

Tire Lubricant.....229 – 232

Tire Lubricant Brushes.....233

Tire Markers.....244, 245

Tire Mounting Compound.....231, 232

Tire Mounting Paste.....229

Tire Mounting Tools.....154, 155

Tire Paint.....107

Tire Racks.....226, 240 – 242

Tire Repair Charts:

- KEX.....31
- PREMA.....15 – 18
- REMA TIP TOP.....24 – 28

Tire Repair Insert Tools.....33

Tire Repair Materials:

- ATV Kits.....12
- Bias, Agricultural.....10, 22
- Bias, OTR.....22
- Bias, Passenger.....9, 10, 21, 29
- Bias, Truck.....9, 10, 21, 29
- Bicycle Kits.....23
- Cabinets.....13
- Combis & Stems.....8, 13, 21, 29
- Emergency Repairs.....12, 13, 23, 30
- KEX.....29 - 31
- Liner Sealer.....12, 23
- PREMA.....8 - 14
- Radial Reinforced.....30
- Radial, Agricultural.....9, 19
- Radial, OTR.....19
- Radial, Passenger.....8, 9, 19, 29
- Radial, Truck.....8, 9, 19, 29
- REMA TIP TOP.....15 - 28
- Rubber Cleaner.....11, 23, 30
- Tire Talc.....12, 23
- Tube.....11
- Universal.....10, 11, 20, 29
- Vulcanizing Cement.....11, 22, 30

Tire Sealant.....239

Tire Sealant Accessories.....239

Tire Shine.....234

Tire Sling, OTR.....223

Tire Soap.....230

Tire Spreaders.....37, 38

Tire Step.....226

Tire Stud Insertion Tools.....249 – 252

Tire Storage.....240 – 242

Tire Studs.....246, 257

Tire Swabs.....233

Toe Bar.....223

Tool Stand.....223

Torque Indicators.....127 – 129

TPMS:

- ATEQ.....44, 51
- Banded Sensor Accessories.....50
- BARTEC.....44, 46, 48
- Charts.....50
- Chrome Sleeves.....47
- Consumer Literature.....50
- Deflator Caps.....50
- DILL Redi-Sensors.....41, 42
- Dress Up Kits.....47
- EZ Sensors.....41, 45
- Installation Tools.....46, 48
- Licenses - Scan Tools.....44
- Literature.....50
- OBD II Scan Tools.....44, 48, 51
- OE Replacement Sensors, Dill.....43
- OE Rep't Sensors, Schrader.....41
- Point of Purchase Materials.....50
- Redi-Sensors.....41, 42
- Removal Tools.....47
- Retrofit Kits.....46
- Scan Tool Parts & Accessories.....46
- Scan Tool Update Certificates.....44
- Scan Tools.....44, 48, 51
- SCHRADER EZ Sensors.....41, 45
- Service Kit Assortments.....43, 44
- Service Kits, Dill.....43
- Service Kits, Schrader.....44
- Tool Sets.....47
- Torque Tools.....46, 48
- Universal Sensors.....41, 42, 45
- Valve Caps, Black & Grey.....47
- Valve Caps, Green.....50
- Valve Caps, Metal.....50
- Valve Core Tools.....46, 47
- Valve Cores.....47

Triple Interchange Coupler.....199

Tube Deflators.....85

Tube Fitting Brushes.....265

Tube Repair Valves.....86

Tungsten Carbide:

- Balls.....111
- Cones.....111
- Cups.....112
- Donut Wheels.....112
- Flat Wheels.....112
- Pencils.....111
- Rasps.....111
- Rasps, Disposable.....111

U

Uni Mount Wheel Hardware.....121, 122

V

Vacuums, Air.....35, 223

Valve 4-Way Tools.....85

Valve Grommets.....79

Valve Breakers.....225

Valve Cap Tools.....85

Valve Caps

- ALLIGATOR.....83
- Chrome.....84
- Double Seal.....83
- Green.....84, 50
- Large Bore.....80
- Metal.....84
- Plastic.....84
- TPMS.....47, 50
- Truck.....83

Valve Core Tools.....85

Valve Cores.....84, 86

Valve Cores.....47

Valve Extensions:

- AIR-FLEXX.....83
- Flexible Rubber.....82
- Large Bore Bendable.....79
- Metal Bent.....81
- Metal Straight.....78, 81
- Plastic.....79
- Stabilizers.....82
- Steel Braided.....83

Valve Fishing Tools.....85

Valve Hole Plugs.....71, 72

Valve Nut Tools.....85

Valve Pressure Equalizers.....86

Valve Screwdriver Tools.....85

Valve Tools, Large Bore.....80

Valves:

- Air Liquid.....69, 70, 76
- Alcoa, 90 Deg Bend.....71
- Alcoa, Grommet.....76
- Alcoa, O-Ring.....75
- Alcoa, Stabilizers.....82
- Chrome Sleeved.....70
- Custom Wheel.....77
- Enki.....77
- Flush Mount.....77
- High Pressure.....74
- Large Bore, Adaptors.....73
- Large Bore, Screw On.....74
- Large Bore, Spuds.....71
- Large Bore, Straight.....72
- Large Bore, Swivel.....72, 73
- Large Bore, Turret.....73
- Metal Clamp In.....74
- Michelin Replacement.....79
- Motorcycle.....76
- Passenger Snap-In.....67, 70, 74
- Snap-In.....67, 70, 74
- Snap-In, High Pressure.....74
- Specialty.....74, 77, 78
- Super Large Bore.....74
- Super Large Bore.....82
- Tank Valves.....77
- TR400-Series.....67, 70
- TR500-Series.....68



Valves: (cont'd)
.....TR510-Series.....71
.....TR540-Series.....75
.....TR550-Series.....76
.....TR570-Series.....68, 69
.....TR600-Series.....74
.....TR670-Series.....72
.....TR800-Series.....74
.....Tube Repair.....86
.....Tubeless Truck, Brass.....68, 69
.....Tubeless Truck, Low Profile.....74
Vehicle Protection:
.....Fender Covers.....260
.....Floor Mats.....256, 257
.....Parts Bags.....256
.....Seat Covers.....256
.....SlipNGrip Startup Kits.....255
.....Steering Wheel Covers.....259, 260
.....Tire Bags.....259
Vent Cord.....113
Vice Grips.....35
Vulcanizing Equipment.....116 - 118

W

Wheel Balancer Accessories:
.....Adaptor Arm, Truck.....132
.....Adaptors.....130
.....Calipers.....204
.....Centering Kits, HD.....134
.....Collets.....131
.....Cone Covers.....204
.....Cones.....131
.....Flange Plates.....134
.....HAWEKA.....130 - 134
.....Nuts.....204
.....Pressure Cup Rings.....204
.....Quick Nuts.....132, 133
.....Quick Plates.....134
.....Rim Bolt Circle Gauges.....204
.....Shafts.....133
.....Shafts.....204
.....Springs.....204
Wheel Chocks.....224
Wheel Covers.....122
Wheel Dollies.....222
Wheel Guards.....121, 122
Wheel Hardware:
.....Cap Nuts.....122
.....Clamps.....123
.....Inner Nuts.....122
.....Outer Nuts.....122
.....Rim Centering Guides.....122
.....Skirt Nuts.....122
.....Studs.....123
Wheel Nut Gauge.....121
Wheel Nut Indicators.....127 - 129
Wheel Stud Thread Gauges.....223
Wheel Weight Hammers.....64, 130
Wheel Weights, 3M Composite:
.....Accessories.....62
.....Adhesive Rolls.....61

Wheel Weights, 3M Composite:
(cont'd)
.....Surface Prep Solution.....62
Wheel Weights, Lead:
.....Adhesive Strips.....58
.....Assortments.....62, 63
.....AW-Series.....54
.....CT-Series (Truck).....57
.....EN-Series.....56
.....FN-Series.....56
.....I7-Series (Truck).....57
.....IAW-Series.....54
.....LH-Series.....55
.....LTI-Series.....56
.....MC-Series.....55
.....P-Series.....53
.....RC-Series (Truck).....57
.....RUC-Series Adhesive.....58
.....TAL-Series (Truck).....57
.....TN-Series.....56
Wheel Weights, Misc Accessories:
.....Racks.....62 - 64
.....Replacement Bins.....64
.....Rim Gauges.....64
Wheel Weights, Steel:
.....Adhesive Rolls.....60, 61
.....Adhesive Strips.....60, 61
Wheel Weights, Zinc:
.....Adhesive Strips, Coloured.....59, 65
Whip Hoses.....159
Whitewall Cleaners.....234
Wicking Pads.....113
Winch Winding Tools.....226
Work Lights.....35, 121
WYCO.....115
Z
ZAFETY Lock.....127



**DID YOU KNOW PREMA CARRIES A FULL
LINE OF TIRE REPAIR EQUIPMENT AND
SUPPLIES AND IS IN YOUR AREA?**

An extensive line of brand name products, all competitively priced.

Your Local Authorized Distributor:

Prema Canada
3230 Mainway, Burlington, ON L7M 1A5
Toll Free: 1.800.268.6311 Phone: 905.628.2303 Fax: 905.628.3646
www.premacanada.ca sales@premacanada.ca